

SPAREPARTS LIST

Electric Stacker PS 20

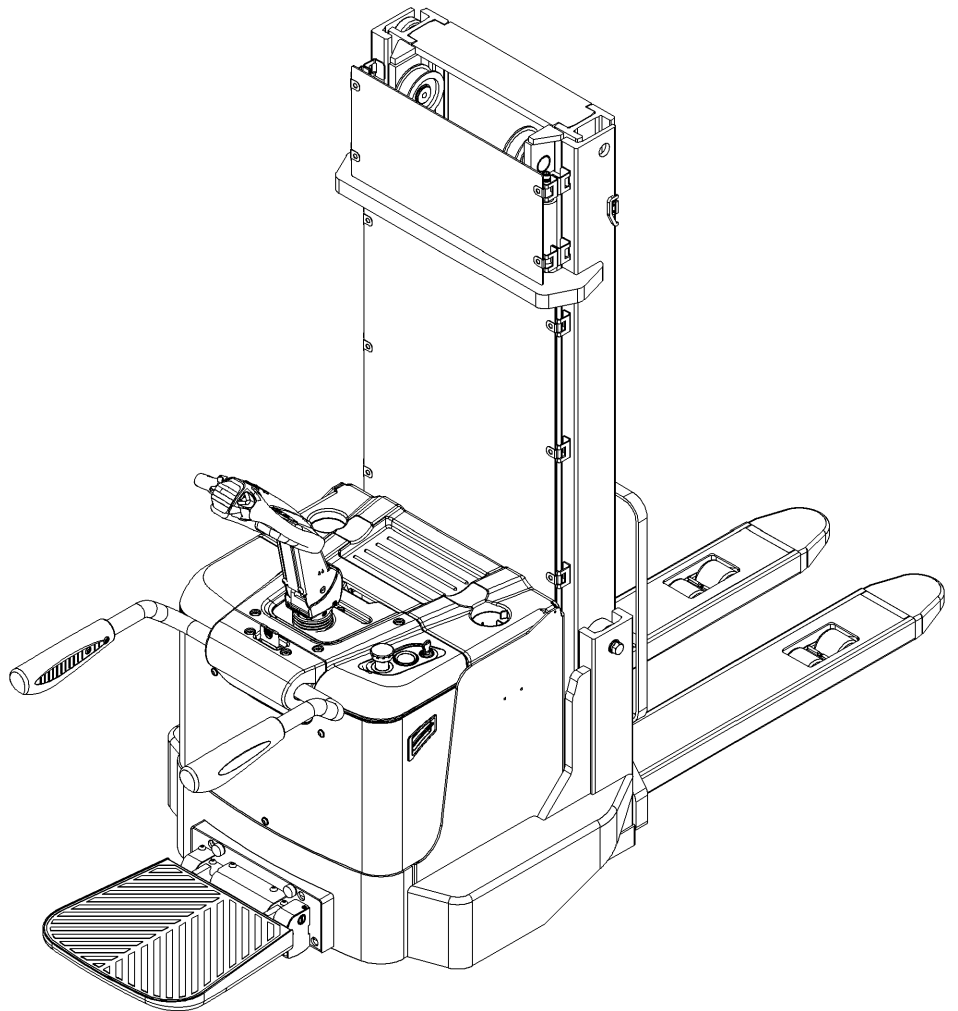

Version 12/2014

From truck identification number:

30130700011

PS 20-BPT-001-EN

目 录

Fig. 1 Label (for EU)	1
Fig. 2 Label (for US)	3
Fig. 3 Outline.....	5
Fig. 4 Chassis	7
Fig. 5 Chassis system.....	9
Fig. 6 Steering wheel assembly.....	11
Fig. 7 Load wheel assembly (tandem roller)	13
Fig. 8 Truck body	15
Fig. 9 Power supply	17
Fig. 10 Instrument assembly	19
Fig. 11 Battery cover assembly	21
Fig. 12 Mast system.....	23
Fig. 13 Mast lifting system	25
Fig. 14 Mast other accessories.....	27
Fig. 15 Hydraulic system	29
Fig. 16 Cylinder.....	31
Fig. 17 Manual steering wheel carrier	33
Fig. 18 Electric power assisted steering wheel carrier	35
Fig. 19 Electric steering assembly.....	37
Fig. 20 7EL-AC-1.3 Drive wheel assembly.....	39
Fig. 21 26EL-AC-1.3KW-R Drive wheel assembly.....	43
Fig. 22 Handle lever.....	47
Fig. 23 CANBUS Handle head	49
Fig. 24 Pump station system (3.0KW 3.2 delivery capacity)	51
Fig. 25 Main circuit wiring (Electrical steering)	53
Fig. 26 Main circuit wiring (Manual steering)	55
Fig. 27 General electrical parts.....	57
Fig. 28 Electric control assembly(Electrical steering).....	59

Fig. 29 Electric control assembly(Manual steering)	63
Fig. 30 Foldable platform	67
Fig. 31 Protective arm.....	69
Fig. 32 Backrest.....	71
Easy worn parts list.....	73

Fig. 1 Label (for EU)

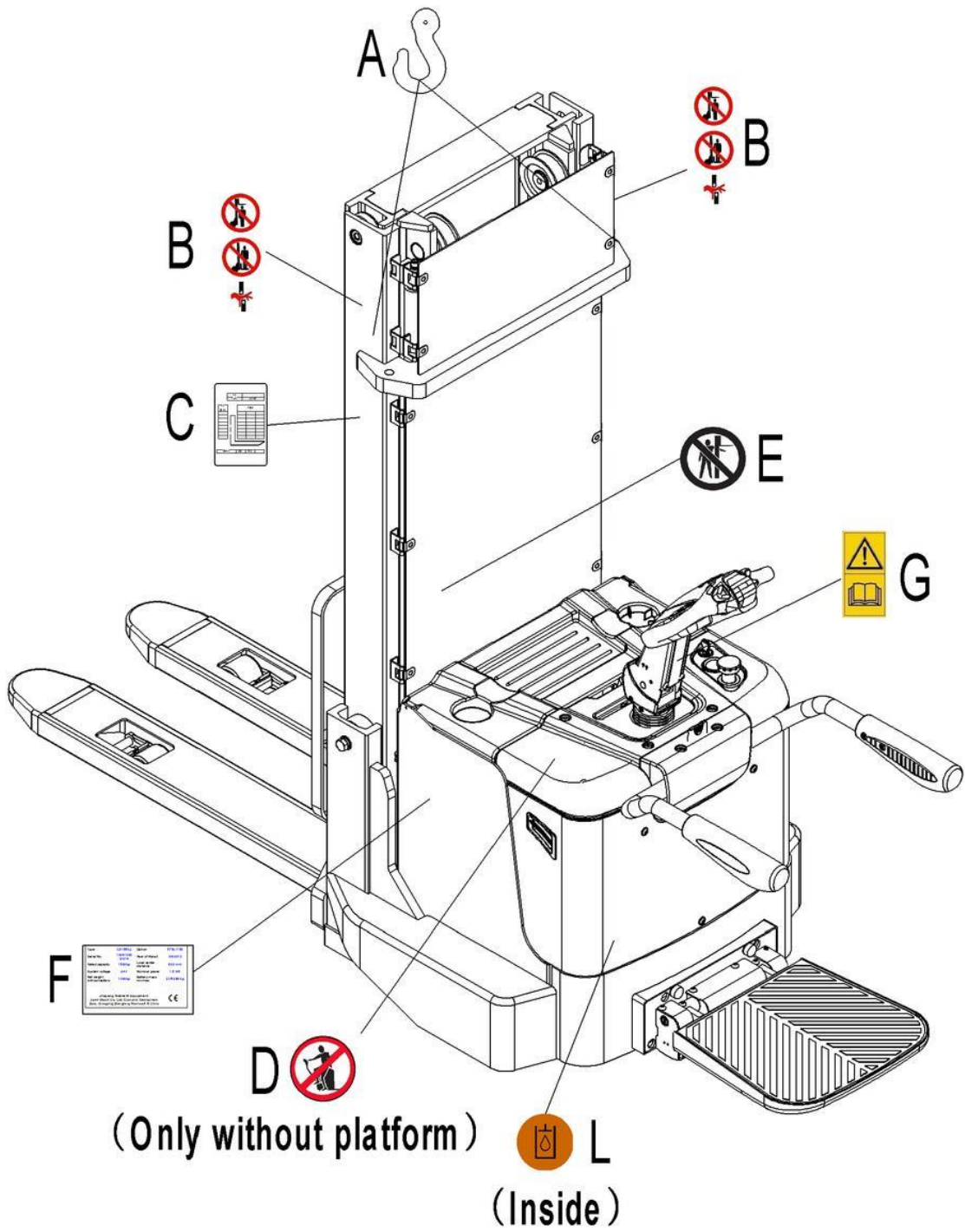

Fig. 1 Label (for EU)

No.	Art No.	Description	Qty.	Note
A	9000005967	Crane hook label	2	
B	9000003923	Warning decal: Do not step under or on the forks	2	
C	9000010338	Residual lift capacity sticker	1	
D	9000003573	'No passengers' decal	1	
E	9000008561	Never reach through	1	
F	9000010339	Identification plate	1	
G	9000003570	Sticker to read and follow these instructions	1	
L	9000008555	Filling sticker	1	

Fig. 2 Label (for US)

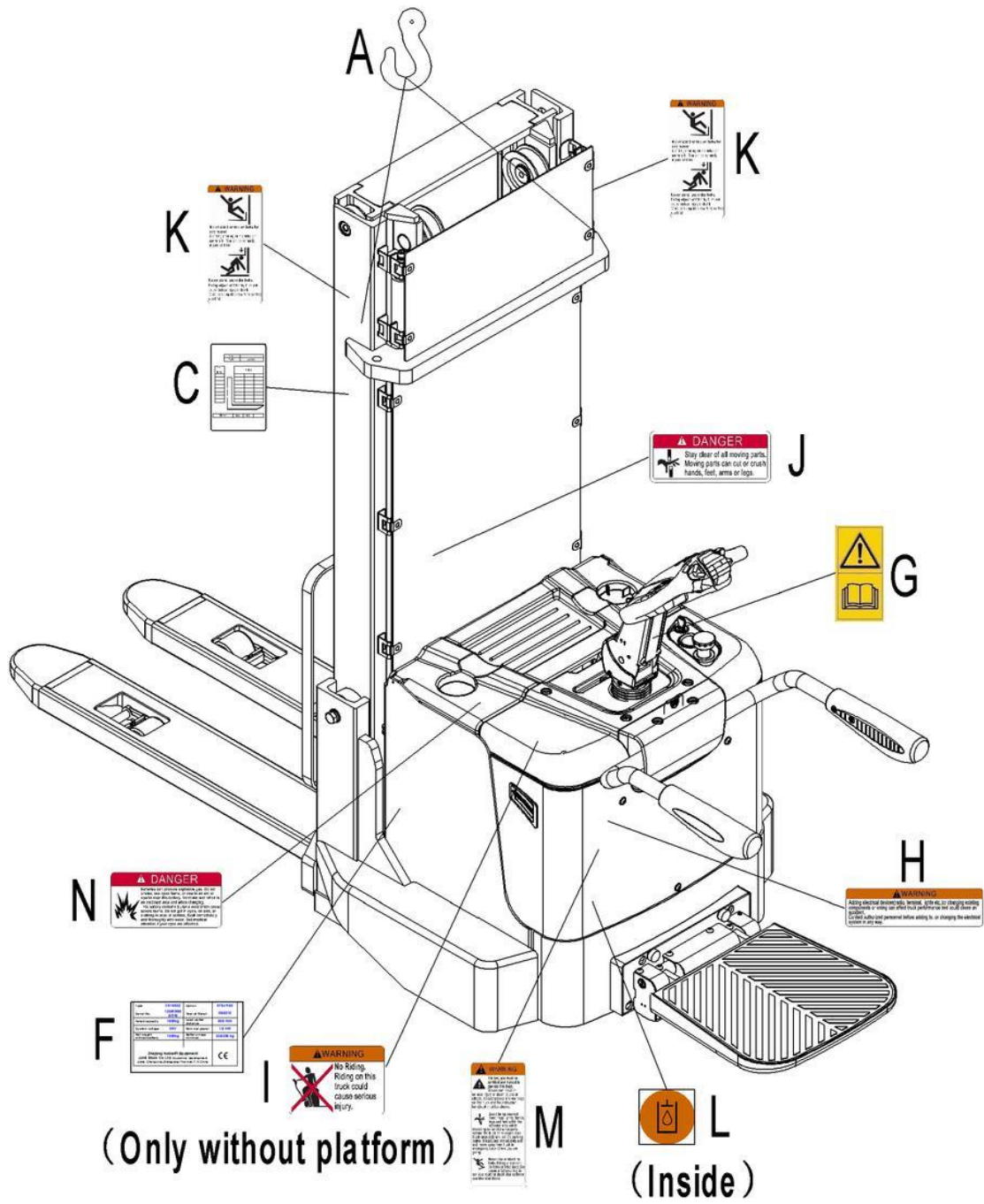

Fig. 2 Label (for US)

No.	Art No.	Description	Qty.	Note
A	9000005967	Crane hook label	2	
C	9000010338	Residual lift capacity sticker	1	
F	9000010339	Identification plate (ID-plate)	1	
G	9000003570	Sticker to read and follow these instructions	1	
H	9000003579	Warning label	1	
I	9000003580	Warning label	1	
J	9000005970	Warning label	1	
K	9000005971	Warning label	2	
L	9000008555	Filling sticker	1	
M	9000003575	Warning label	1	
N	9000003577	Warning label	1	

Fig. 3 Outline

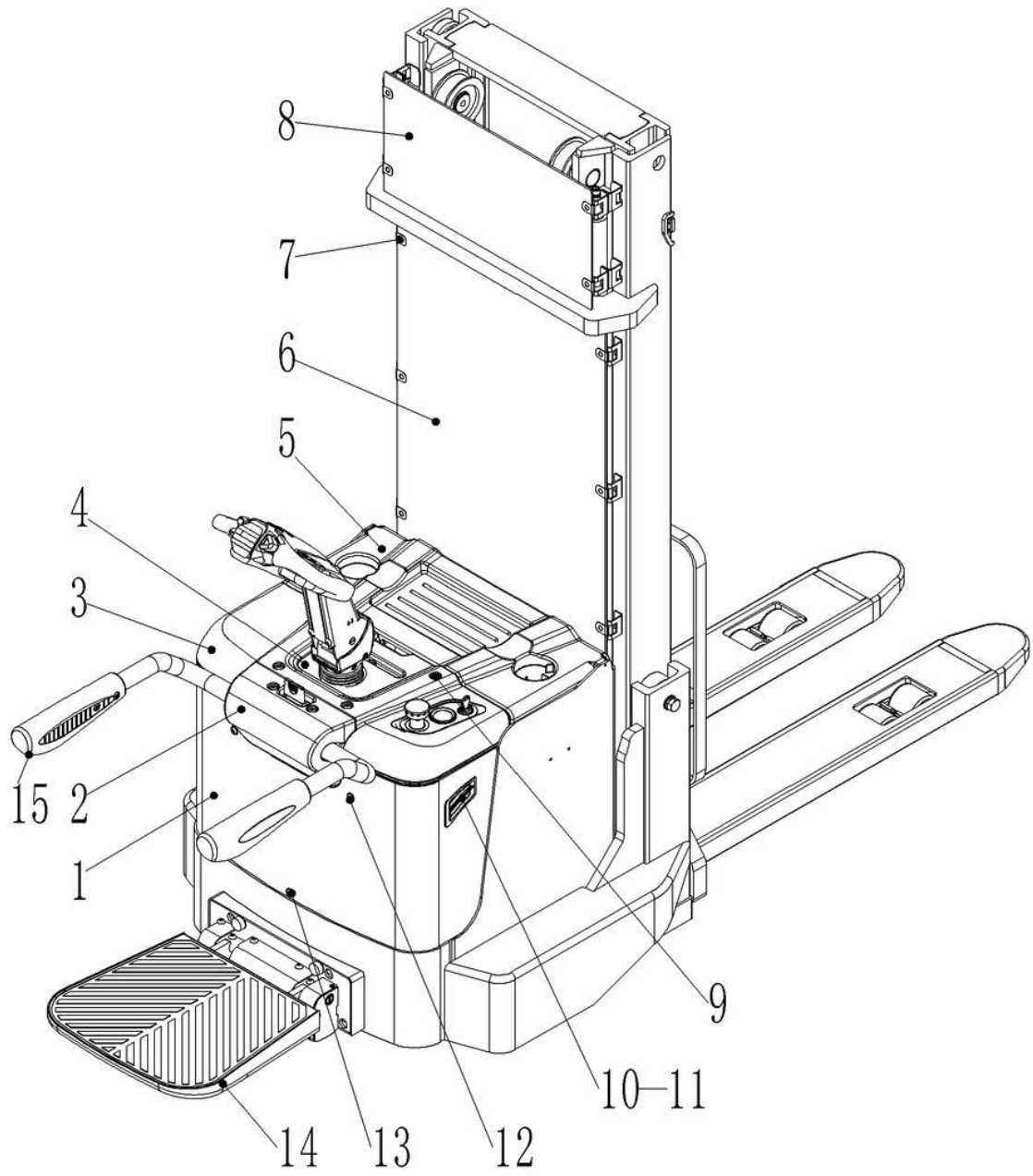

Fig. 3 Outline

No.	Art No.	Description	Qty.	Note
1	900008061	Cover	1	
2	900008063	Cover	1	
3	900008062	Cover	1	
4	900008065	Cover	1	
5	900008229	Battery cover	1	
6	9000010719	Protective board	1	2900
	9000010720			2600
	9000010721			3600
7	900007782	Buckle	10	
8	9000010722	Protective board	1	
9	900007790	Screw	2	M10X55
10	900007923	Right vents components	1	
11	900007920	Left vents components	1	
12	900007791	Screw	7	M10×35
13	900007793	Screw	1	M10×10
14	900007862	Pedal assembly	1	
15	900007891	Protective arm assembly	1	

Fig. 4 Chassis

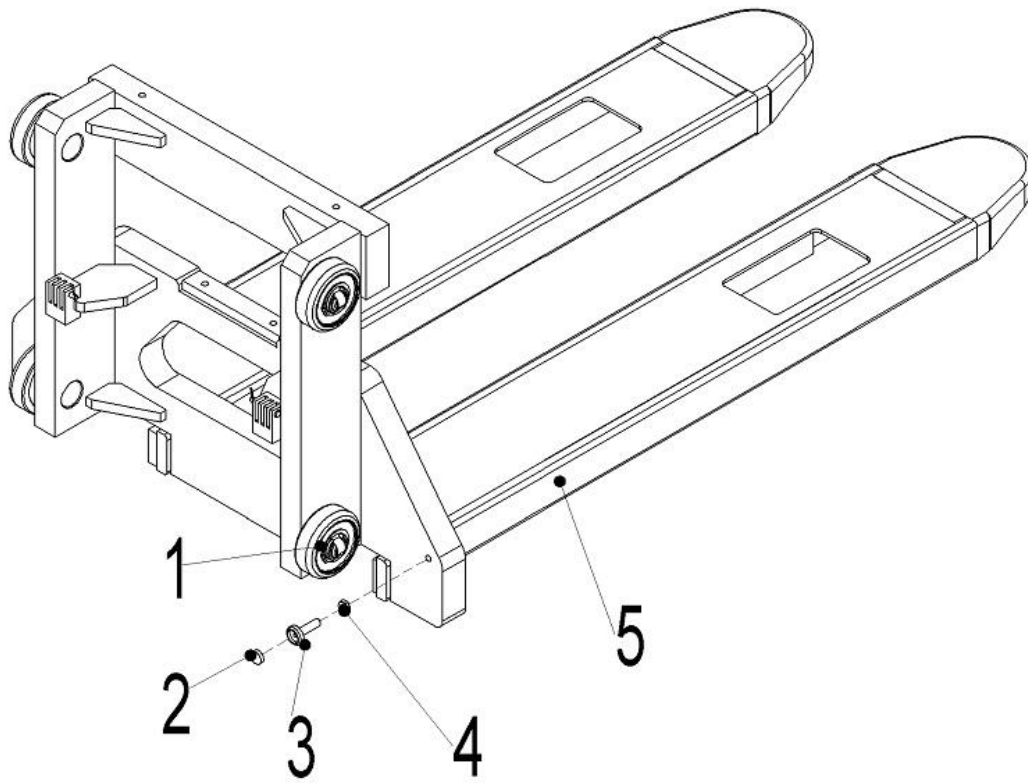

Fig. 4 Chassis

No.	Art No.	Description	Qty.	Note	Standard
1	3500100005	Compound roller	4		
2	2000435002	Magnet steel	1		
3	9000008079	Magnet steel seat	1		
4	0000024012	Nut	1	M10	GB/T6172.1=ISO4035
5	9000010723	Welded pallet frame	1	570X1150	
	9000010724			685X1150	

Fig. 5 Chassis system

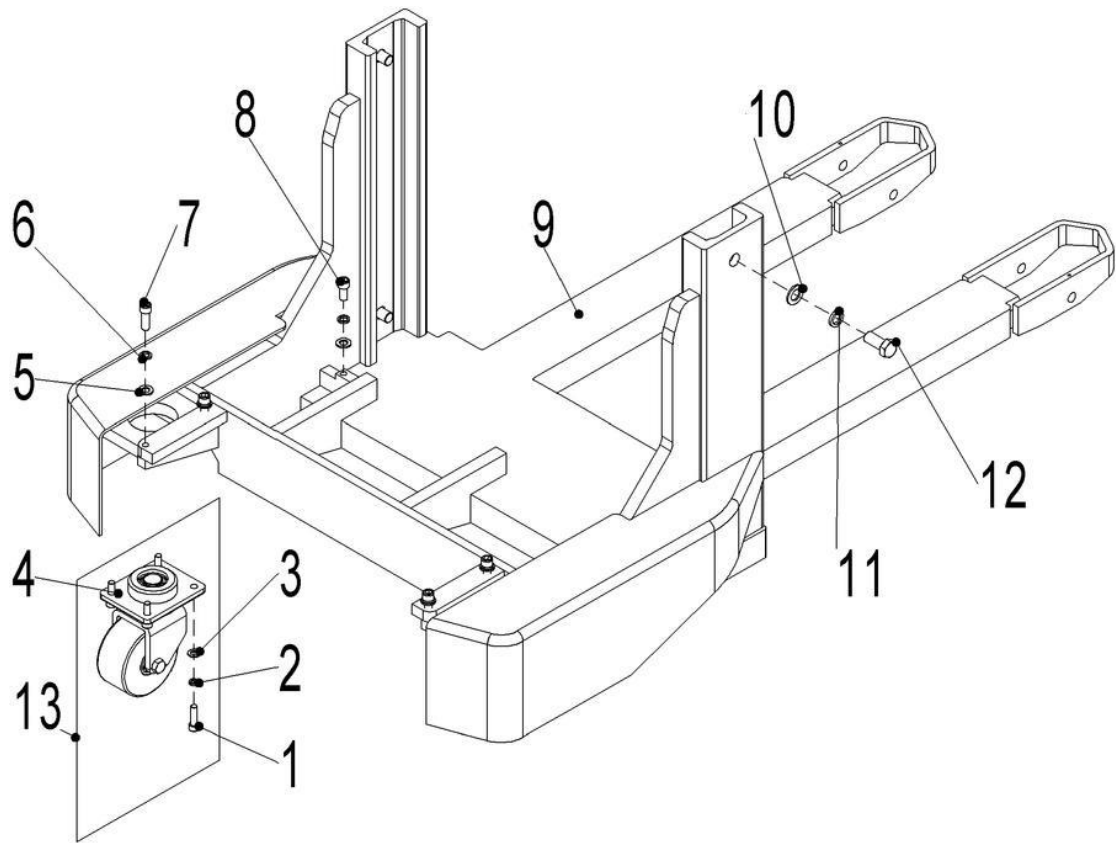

Fig. 5 Chassis system

No.	Art No.	Description	Qty.	Note	Standard
1	0000023029	Screw	8	M10x35	GB/T70.1=ISO4762
2	0000023006	Washer	8	10	GB/T93
3	0000025002	Washer	8	10	GB/T95
4	2040400001	Steering wheel components	2		
5	0000025032	Washer	6	12	GB/T95
6	0000025024	Washer	6	12	GB/T93
7	0000023082	Screw	4	M12x35	GB/T70.1=ISO4762
8	0000023156	Screw	2	M12x25	GB/T70.1=ISO4762
9	9000010725	Welded chassis	1	570X1150	
	9000010726			685X1150	
10	0000025023	Washer	4	18	GB/T95
11	0000025022	Washer	4	18	GB/T93
12	0000023079	Bolt	4	M18x40	GB/T5783=ISO4017
13	9000010408	Steering wheel kit	2		

Fig. 6 Steering wheel assembly

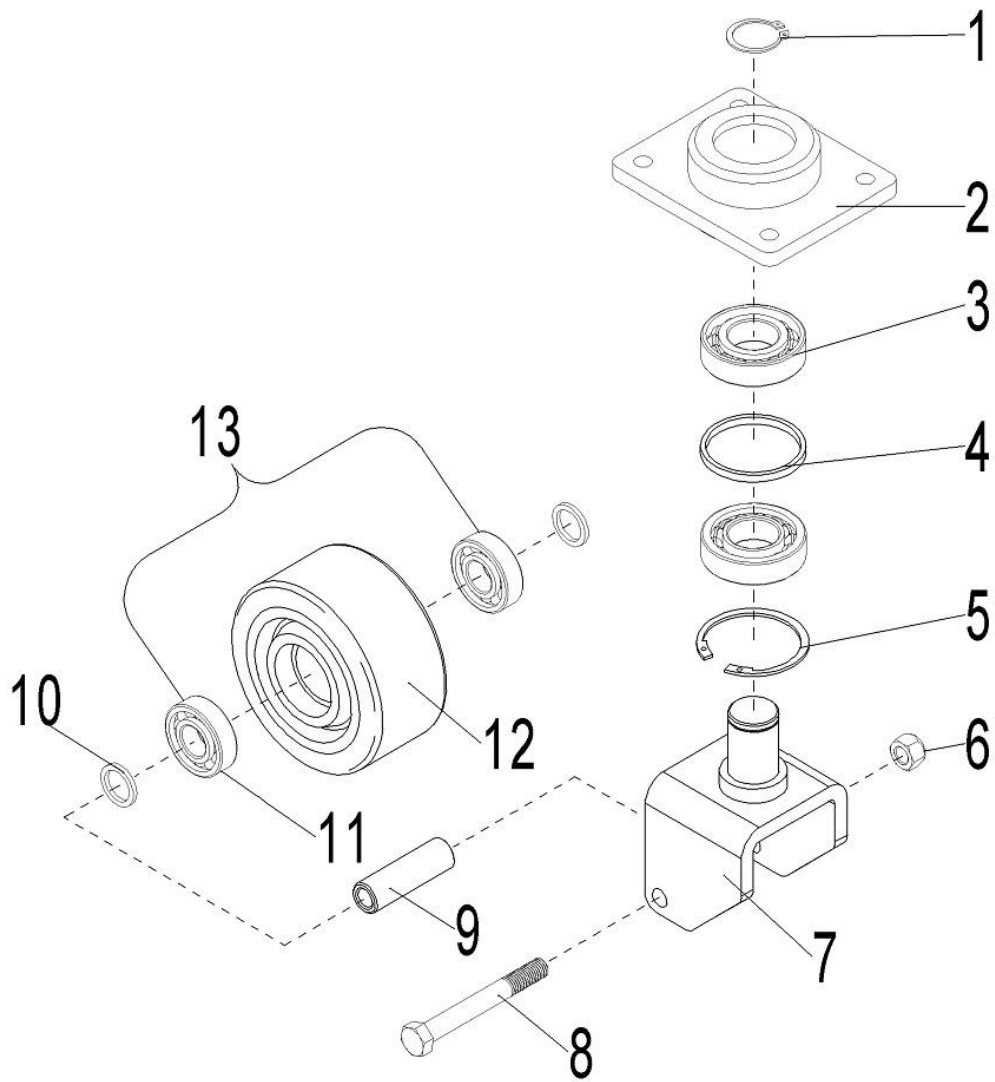

Fig. 6 Steering wheel assembly

No.	Art No.	Description	Qty.	Note	Standard
1	0000026008	Circlip	1	30	GB/T894.1
2	2000405001	Bearing seat	1		
3	0000027013	Ball bearing	2	7206C/DB	GB/T292
4	2000413001	Sleeve	1		
5	0000026010	Circlip	1	62	GB/T893.1
6	0000024015	Lock nut	1	M14	GB/T889.1=ISO7040
7	2000401007	Rear wheel carrier welding	1		
8	0000023111	Bolt	1	M14×100	GB/T5782=ISO4014
9	2000413002	Shaft sleeve	1		
10	1000525001	Washer	2		
11	0000027001	Ball bearing	2	6204	GB/T276
12	2020416001	Castor	1	124×60	
13	9000003638	Castor wheel	2		

Fig. 7 Load wheel assembly (tandem roller)

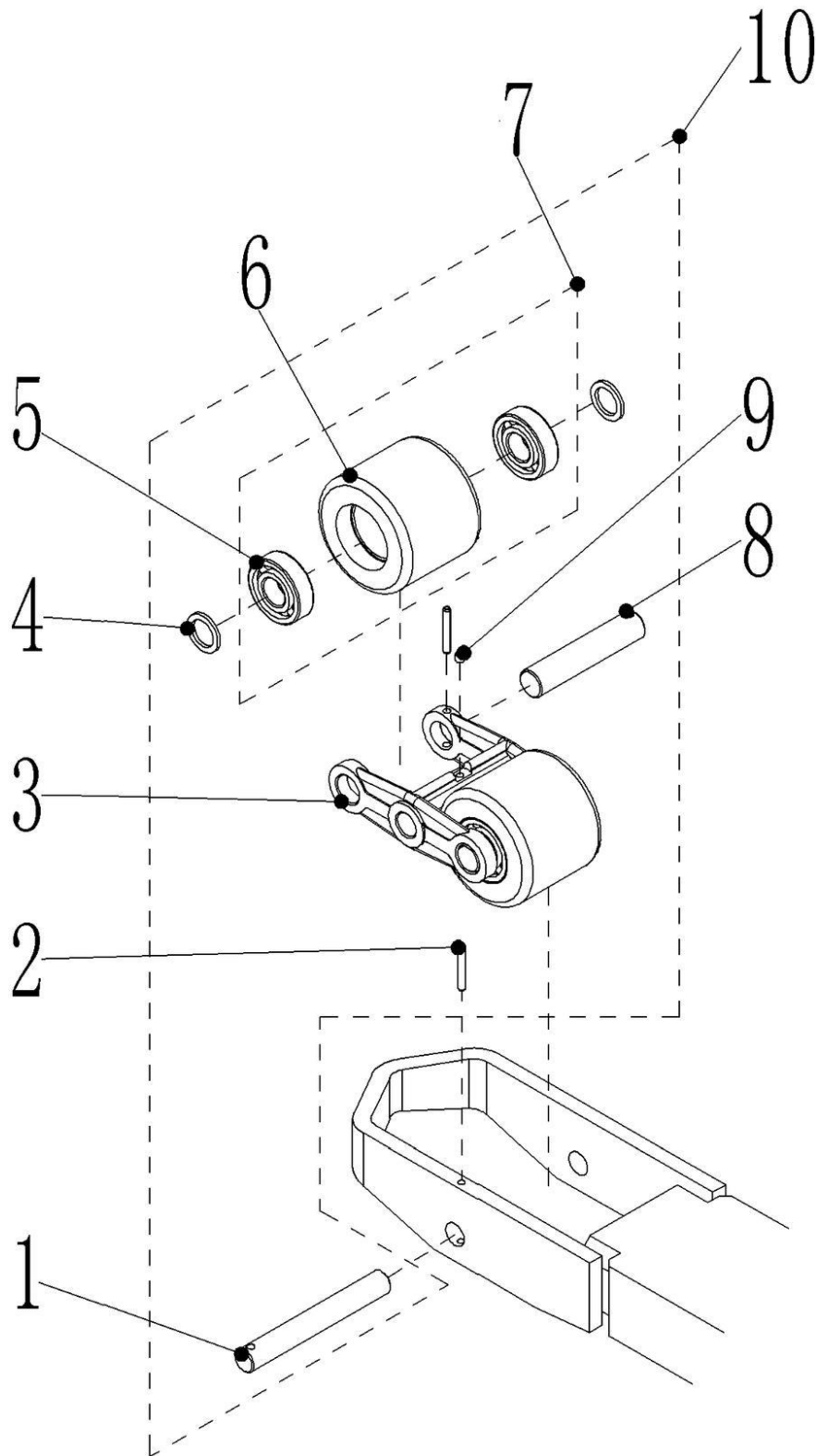

Fig. 7 Load wheel assembly (tandem roller)

No.	Art No.	Description	Qty.	Note	Standard
1	1000507014	Shaft	2		
2	0000028009	Pin	6	5x35	GB/T879.1=ISO8752
3	1000505008	Wheel frame	2		
4	9000010718	Washer	8		
5	0000027001	Bearing	8	6204	GB/T276
6	1000507011	Wheel	4	∅84X70	
7	9000010727	Wheel set kit	4		
8	1000507015	Shaft	4		
9	0000030001	Grease nipples	1	6	JB/T7940.4=ISOB1575
10	9000010728	Load roller assembly	2		

Fig. 8 Truck body

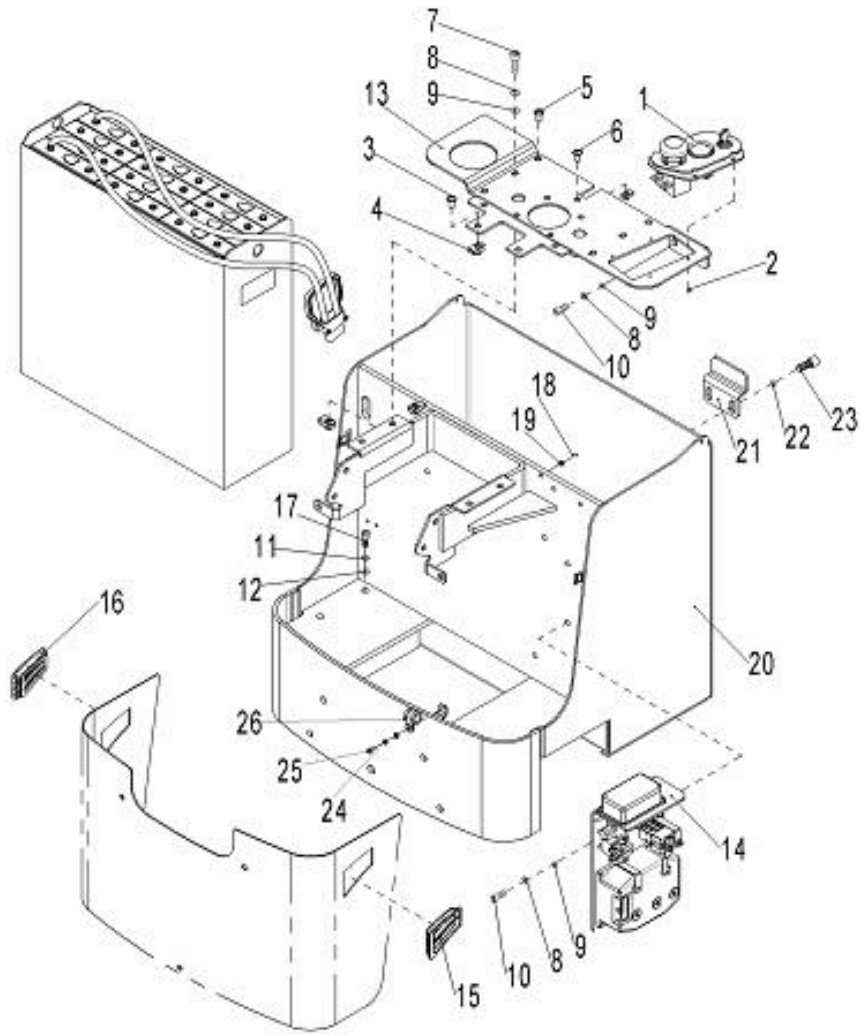

Fig. 8 Truck body

No.	Art No.	Description	Qty.	Note	Standard
1	9000007940	Instrument assembly	1		
2	0000023020	Screw	4	M6×20	GB/T70.1=ISO4762
3	9000007791	Screw	4	M10×35	
4	9000007783	Nut	13	M10	
5	9000007790	Screw	2	M10×55	
6	1000423003	Screw	1	M10×30	
7	0000023029	Screw	4	M10×35	GB/T70.1=ISO4762
8	0000023006	Washer	8	10	GB/T93
9	0000025002	Washer	8	10	GB/T95
10	0000023034	Screw	4	M10×20	GB/T70.1=ISO4762
11	0000025024	Washer	4	12	GB/T93
12	0000025032	Washer	4	12	GB/T95
13	9000008240	Board	1		
14	9000008069	Electronic control assemble board	1		
15	9000007923	Right vent components	1		
16	9000007920	Left vent components	1		
17	0000023082	Screw	4	M12×35	GB/T70.1=ISO4762
18	0000023455	Screw	2	M8×35	GB/T70.1=ISO4762
19	0000024026	Nut	2	M8	GB/T6170=ISO4032
20	9000008241	Welded body	1		
21	9000009080	Upper plate of protective board	2		
22	0000025014	Washer 5	5	5	GB/T95
23	0000023311	Screw M5x10	4	M5x10	GB/T70.1=ISO4762
24	0000025010	Washer	1	6	GB/T93
25	0000023053	Screw	1	M6x12	GB/T70.1=ISO4762
26	9000009545	YGE rubber pipe clamp	1		

Fig. 9 Power supply

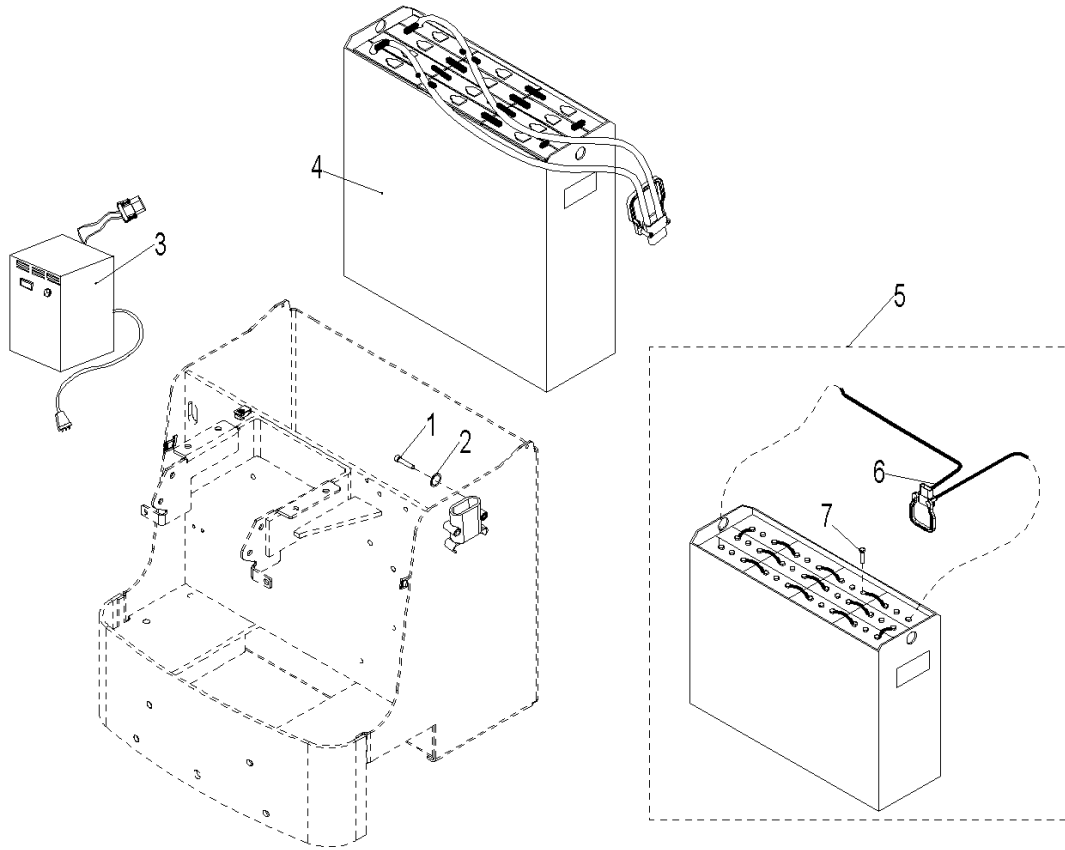

Fig. 9 Power supply

No.	Art No.	Description	Qty.	Note	Standard
1	0000023106	Screw	2	M6×30	GB/T70.1=ISO4762
2	0000023055	Washer	2	6	GB/T95
3	9000010147	Charger 24V/45A(Asia in Chinese)	1		
	9000010148	Charger 24V/45A(Asia in English)			
	9000010194	Charger 24V/45A(For EU)			
	9000010195	Charger 24V/45A(For AUS)			
	9000010196	Charger 24V/45A(For UK)			
	9000010197	Charger 24V/45A(For USA)			
4	9000008322	Power supply (350Ah) welded type	1		
5	9000009835	Power supply (350Ah) bolt type	1		
6	9000003988	Connector components (350Ah) (Three-stage mast)	1	Only used for bolt type battery	
7	9000009832	Bolt	24		

Fig. 10 Instrument assembly

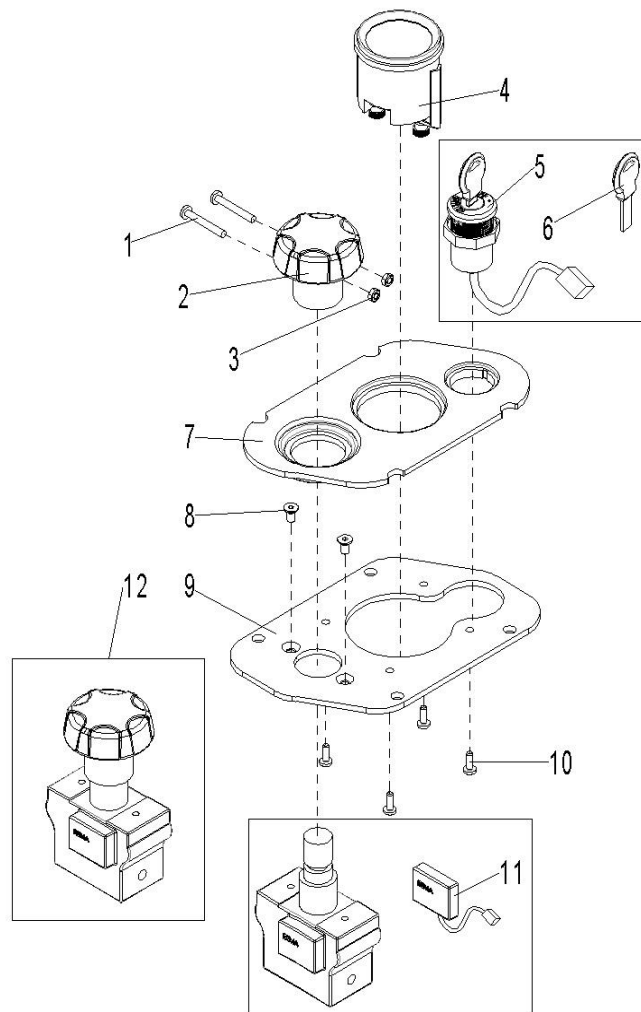

Fig. 10 Instrument assembly

No.	Art No.	Description	Qty.	Note	Standard
1	0000023685	Screw	2	M3x25	GB/T818-2000=ISO7045
2	9000008516	Emergency button	1	ZDK32-350	
3	0000024002	Nut	2	M3	GB/T6170=ISO4032
4	1000434025	Indicator	1	CURTIS 803	
5	9000008326	Key switch	1	LKS-101A	
6	9000008519	Key	1		
7	9000007938	Plastic plate	1		
8	0000023215	Screw	2	M5x10	GB/T70.3=ISO10642
9	9000007939	Fixing plate	1		
10	0090000272	Screw	4	M4x12	GB/T6560
11	9000008517	Proximity switch	1		
12	9000008515	DC power switch	1	ZDK32-350	

Fig. 11 Battery cover assembly

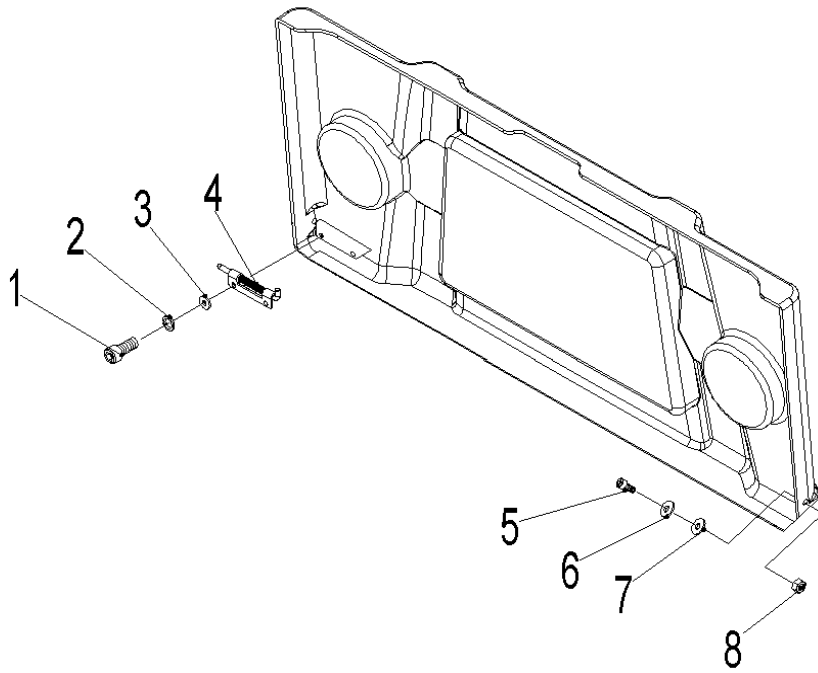

Fig. 11 Battery cover assembly

No.	Art No.	Description	Qty.	Note	Standard
1	0000023073	Screw	2	M4×10	GB/T70.1=ISO4762
2	0000025018	Washer	2	4	GB/T93
3	0000025019	Washer	2	4	GB/T95
4	9000008795	Pin	1		
5	0000023306	Screw	1	M5×20	GB/T70.1=ISO4762
6	0000025015	Washer	1	5	GB/T93
7	0000025014	Washer	1	5	GB/T95
8	0090000636	Nut	1	M5	GB/T6172.1=ISO4035

Fig. 12 Mast system

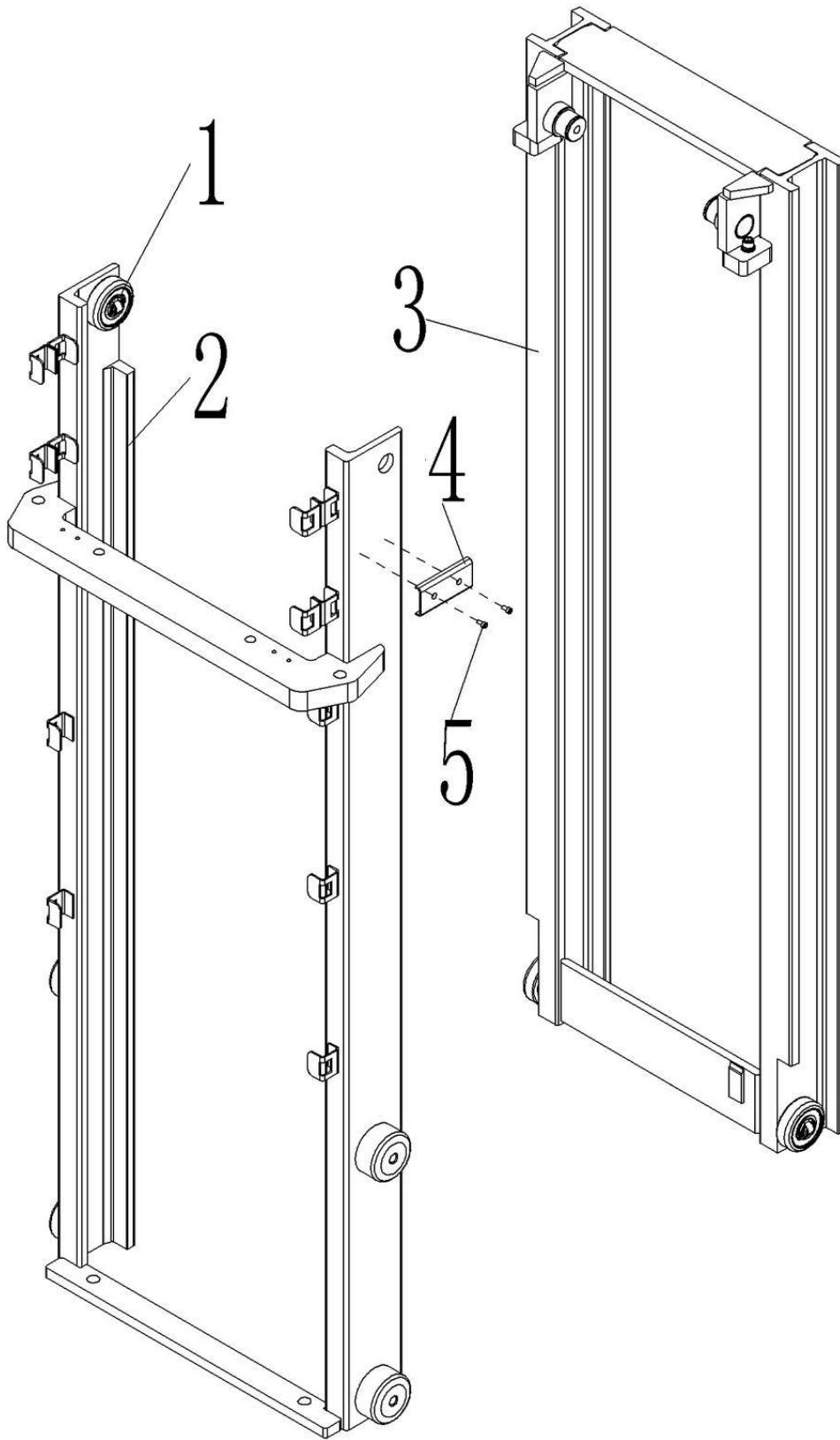

Fig. 12 Mast system

No.	Art No.	Description	Qty.	Note
1	3500100004	Compound roller	4	
2	9000010729	Welded mast	1	2900
	9000010730			2600
	9000010731			3600
3	9000010732	Welded mast	1	2900
	9000010733			2600
	9000010734			3600
4	9000013694	cover	1	
5	0000023053	Screw	2	GB/T70.1=ISO4762

Fig. 13 Mast lifting system

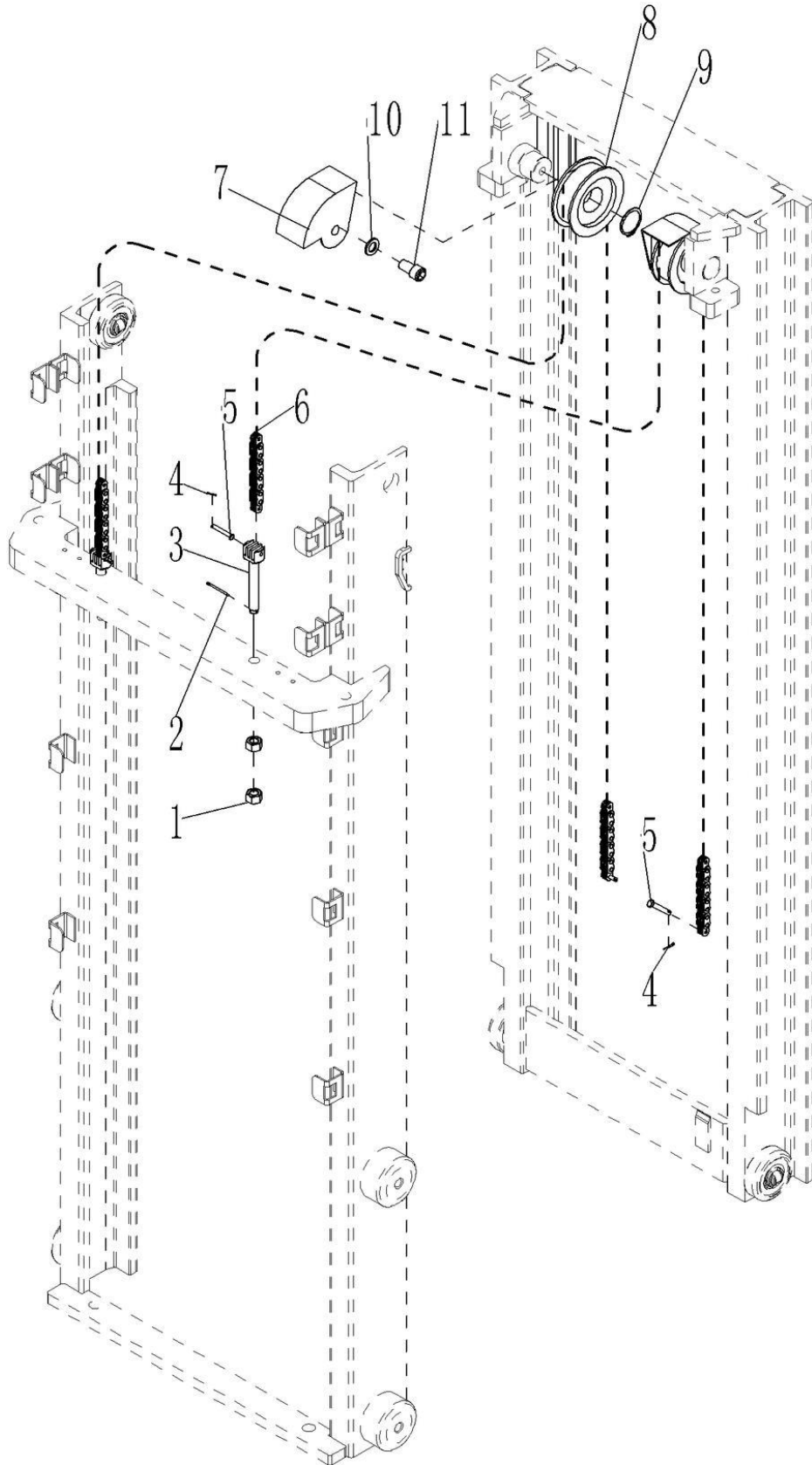

Fig. 13 Mast lifting system

No.	Art No.	Description	Qty.	Note	Standard
1	0000024042	Nut	4	M16x1.5	GB/T6171=ISO8673
2	0000028011	Pin	2	3x40	GB/T91=ISO1234
3	9000008260	Bolt	2		
4	0000028010	Pin	4	2x20	GB/T91=ISO1234
5	0000028030	Pin axle	4	6x45	GB/T882=ISO2341
6	0090000540	Chain	2	LH1066x135, 2900	GB/T882=ISO2341
	0090000661			LH1066x125, 2600	
	0090000662			LH1066x157, 3600	
7	9000010747	Cover	2		
8	9000007762	Chain wheel	2		
9	0000026049	Circlip	2	45	GB/T894.1
10	0000025029	Nut	2	16	GB/T95
11	0000023438	Screw	2	M16x30	GB/T70.1=ISO4762

Fig. 14 Mast other accessories

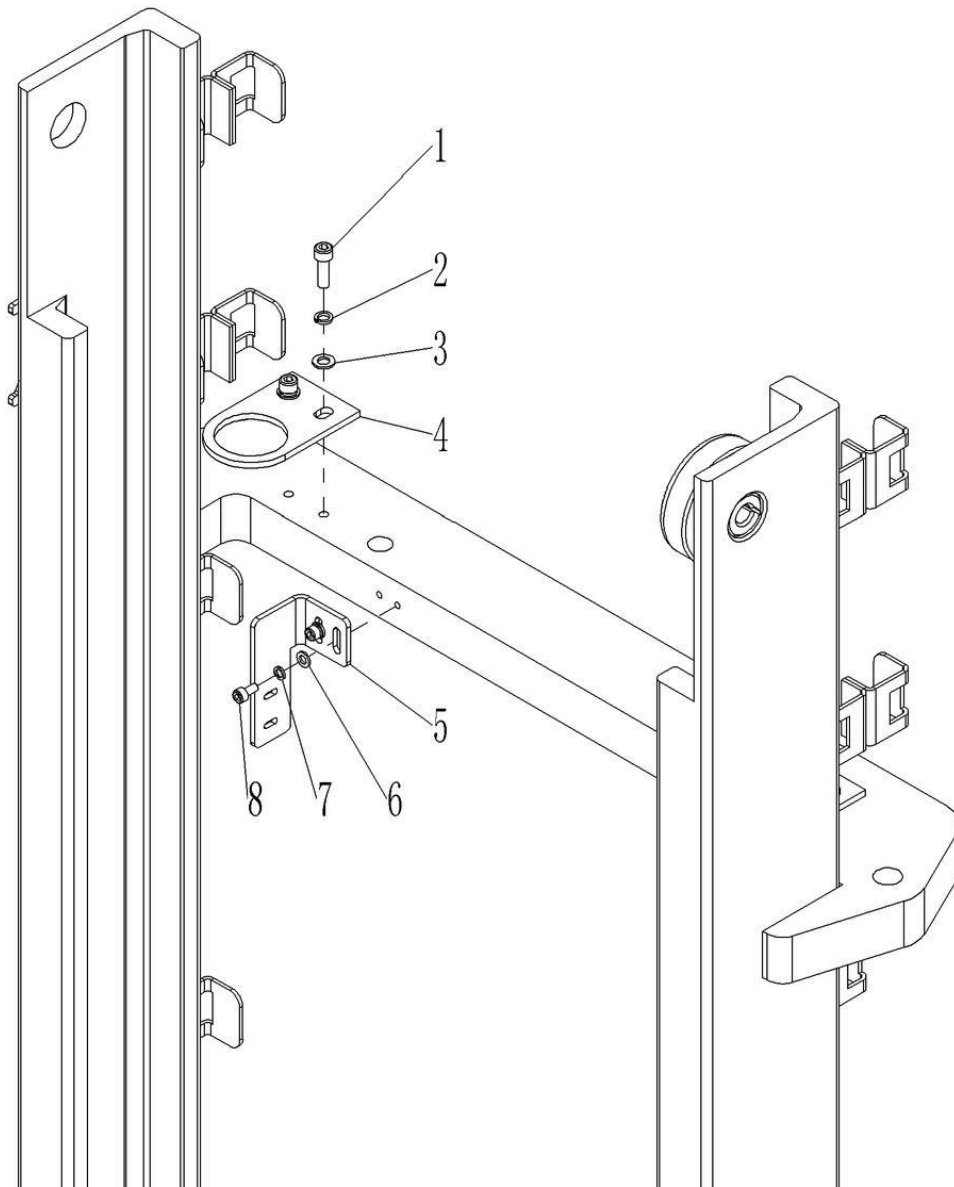

Fig. 14 Mast other accessories

No.	Art No.	Description	Qty.	Note	Standard
1	0000023047	Screw	4	M8x25	GB/T70.1=ISO4762
2	0000025001	Washer	4	8	GB/T93
3	0000025011	Washer	4	8	GB/T95
4	9000010735	Fixing plate	2		
5	9000010736	Assembly board	1		
6	0000023053	Screw	2	M6x12	GB/T70.1=ISO4762
7	0000025010	Washer	2	6	GB/T93
8	0000023055	Washer	2	6	GB/T95

Fig. 15 Hydraulic system

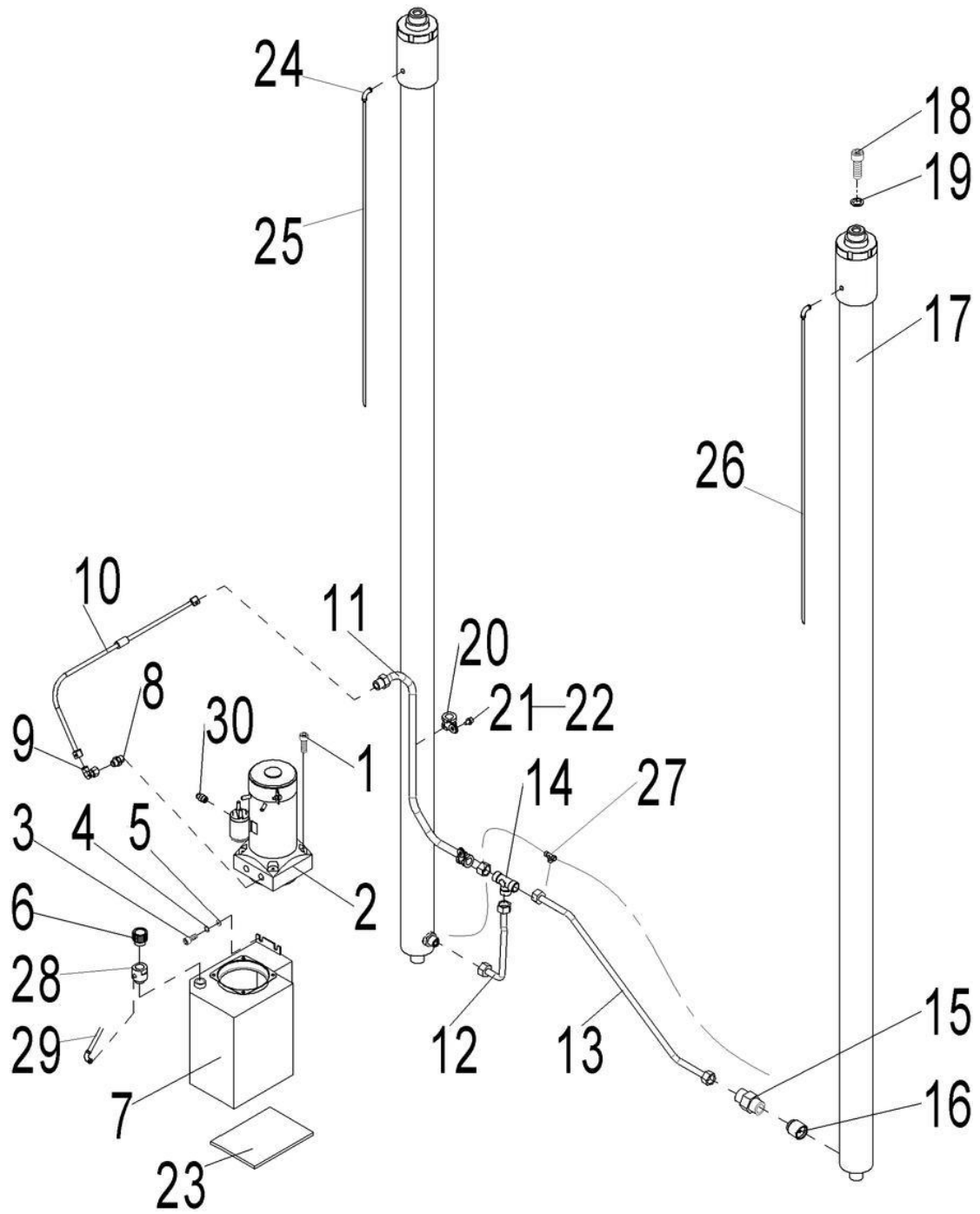

Fig. 15 Hydraulic system

No.	Art No.	Description	Qty.	Note	Standard
1	0000023090	Screw	4	M6x35	GB/T70.1=ISO4762
2	9000008867	Pump station	1		
3	0000023044	Screw	2	M8x20	GB/T70.1=ISO4762
4	0000025001	Washer	2	8	GB/T93
5	0000025011	Washer	2	8	GB/T95
6	2000303001	Cylinder cover	1		
7	9000008249	Welded cylinder	1		
8	9000007832	Joint	1		
9	9000007838	Joint	1		
10	9000010283	Pipe	1		
11	9000008250	Steel pipe	1		
12	9000010737	Steel pipe	1		
13	9000010738	Steel pipe	1		
14	9000007846	Joint	1		
15	9000007842	Joint	2		
16	2000337001	Safety valve	2		
17	9000010739	Cylinder	2	2900	
	9000010740		2	2600	
	9000010741		2	3600	
18	0000023094	Screw	2	M12x30	GB/T70.1=ISO4762
19	0000025032	Washer	2	12	GB/T95
20	9000008324	Pipe clamp	2		
21	0000023042	Screw	2	M6x10	GB/T70.1=ISO4762
22	0000023055	Washer	2	6	GB/T95
23	9000010307	Pad	1		
24	2010317002	Joint	3		
25	9000010748	Oil return tube	1	2900	
	9000010742			2600	
	9000010743			3600	
26	9000010744	Oil return tube	1	2900	
	9000010745			2600	
	9000010746			3600	
27	2250317004	Joint	1		
28	2010317003	Joint	1		
29	9000010749	Oil return tube	1		
30	9000011773	throttle valve	1		

Fig. 16 Cylinder

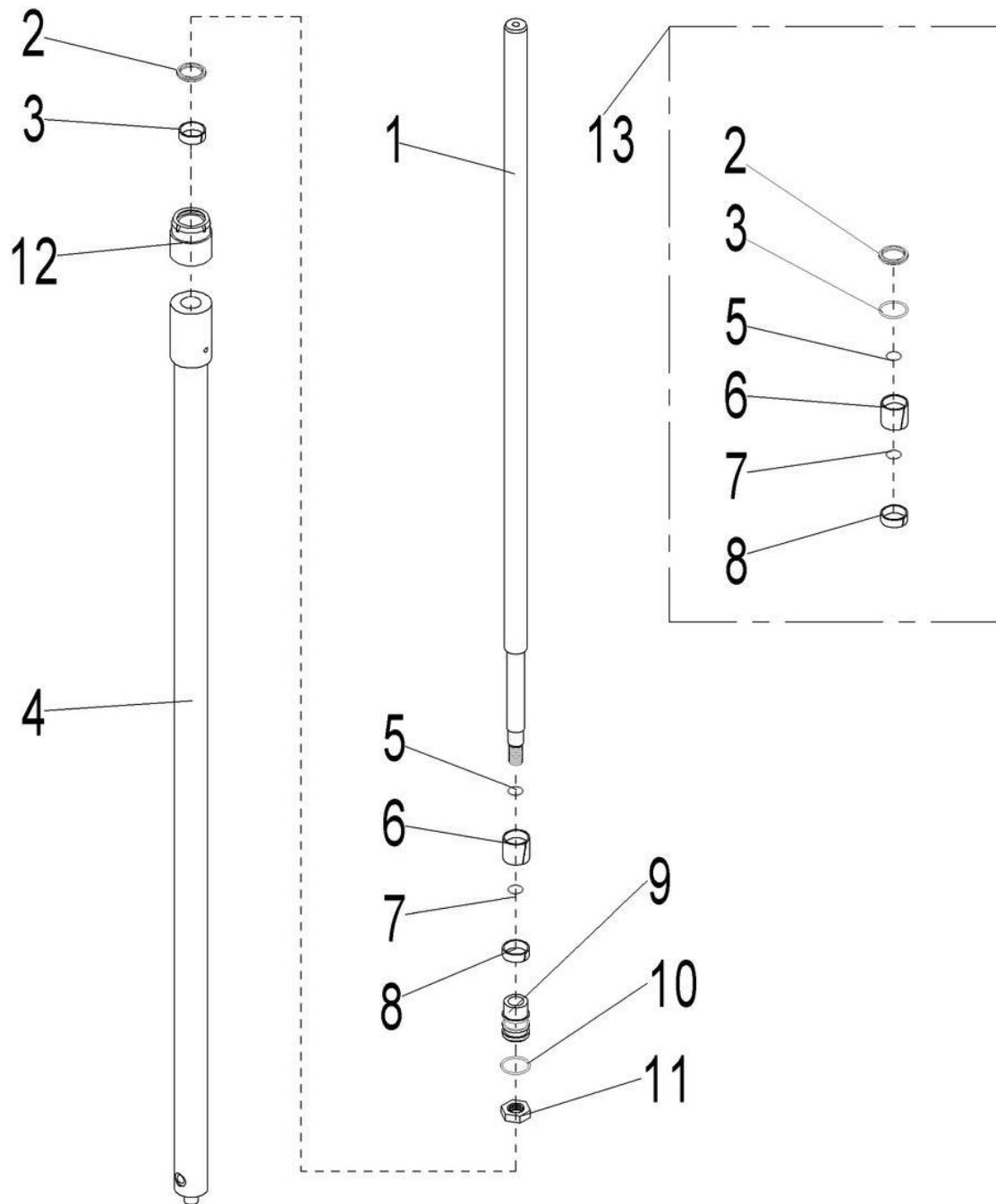

Fig. 16 Cylinder

No.	Art No.	Item	Qty.	Note	Standard
1	9000010752	Piston rod	2	2900	
	9000010753			2600	
	9000010754			3600	
2	9000009718	Dust cover	2		
3	9000010760	Support ring for shaft	2		
4	9000010755	Cylinder body	2	2900	
	9000010756			2600	
	9000010757			3600	
5	0000022153	O ring	2	40x3.1	
6	9000008955	Support ring for hole	2		
7	0000022014	O ring	4	25x3.1	
8	9000010761	Y ring for hole	2	30X40X6/7	
9	9000010758	Piston	2		
10	0000025033	Washer	2	20	GB/T93
11	0000024074	Nut	2	M20x1.5	GB/T6171=ISO8673
12	9000010759	Coer	2		
13	9000010750	Cylinder seal kit	2		

Fig. 17 Manual steering wheel carrier

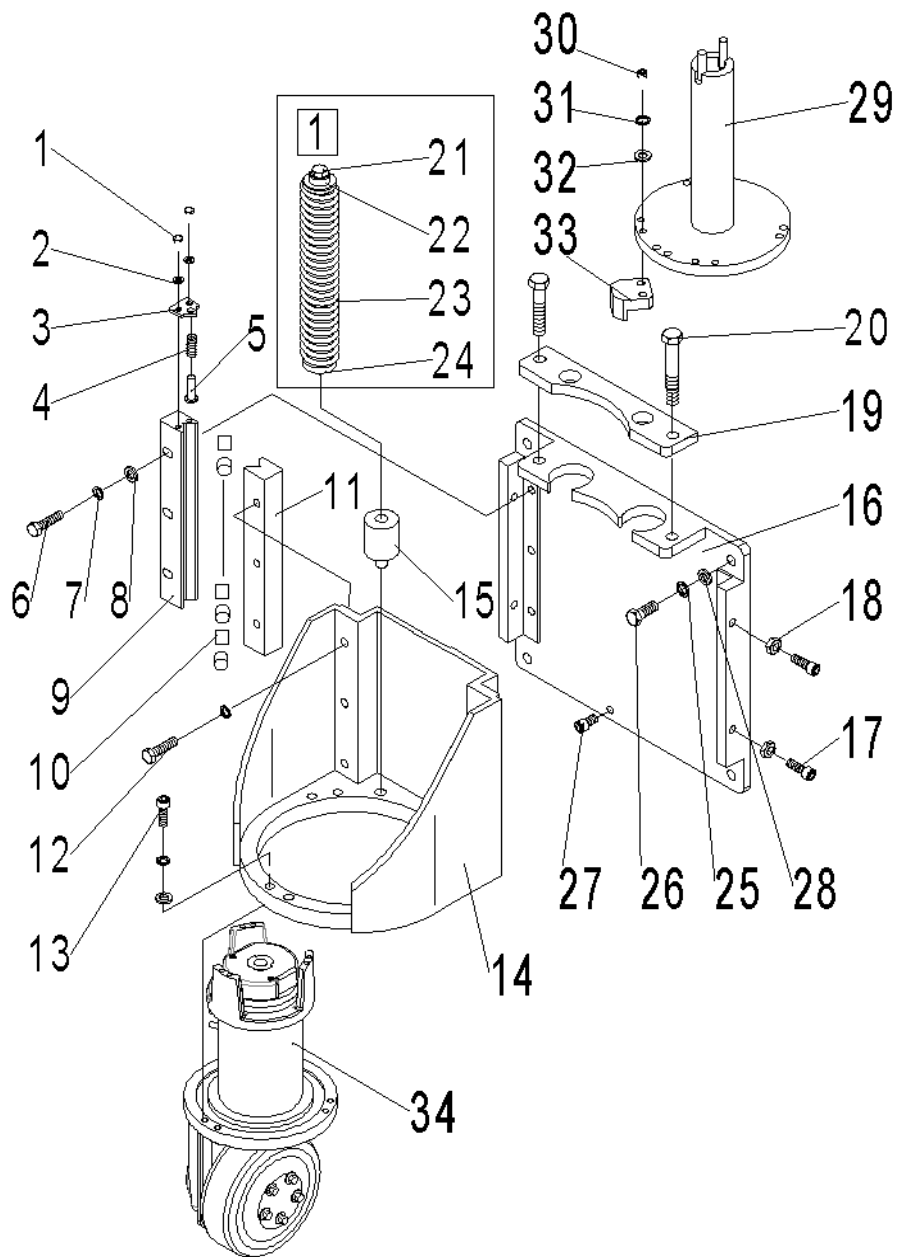

Fig. 17 Manual steering wheel carrier

No.	Art No.	Item	Qty.	Note	Standard
1	0000023042	Screw	8	M6×10	GB/T70.1=ISO4762
2	0000025010	Washer	8	6	GB/T93
3	2000202006	End cover	4		
4	2000231001	Spring	4		
5	2000207001	Spring spindle	4		
6	0000023099	Screw	6	M10×45	GB/T70.1=ISO4762
7	0000023006	Washer	18	10	GB/T93
8	0000025002	Washer	18	10	GB/T95
9	2000202004	V type outer block	2		
10	2000202008	Roller	24		
11	2000202005	V type inner block	2		
12	0000023025	Screw	6	M10×40	GB/T70.1=ISO4762
13	0000023099	Screw	6	M10×45	GB/T70.1=ISO4762
14	2000201005	Wheel carrier welding	1		
15	2000202003	Cushion block	2		
16	2000201004	Supporting frame welding	1		
17	0090000602	Screw	4	M10×25	GB/T821
18	0000024012	Thin nut	4	M10	GB/T6172.1=ISO4035
19	9000008321	Top plate	1		
20	0000023095	Full thread bolt	2	M14×60	GB/T5783=ISO4017
21	2000223001	Screw	2	M10×180	
22	2000208001	Spring guide sleeve	2		
23	2000231002	Spring	2		
24	2000212001	Spring guide rod	2		
25	0000025024	Washer	4	12	GB/T93
26	0000023094	Screw	4	M12×30	GB/T70.1=ISO4762
27	0000023098	Screw	1	M12×10	GB/T70.1=ISO4762
28	0000025032	Washer	4	12	GB/T95
29	9000008257	Handle shaft welding	1		
30	0000023172	Screw	10	M8×30	GB/T70.1=ISO4762
31	0000025001	Washer	10	8	GB/T93
32	0000025011	Washer	10	8	GB/T95
33	2000202001	Limit block	2		
34	9000007774	Vertical type drive	1	7EL-AC-1.3	
□	2000200003	Spring assembly	2		

Fig. 18 Electric power assisted steering wheel carrier

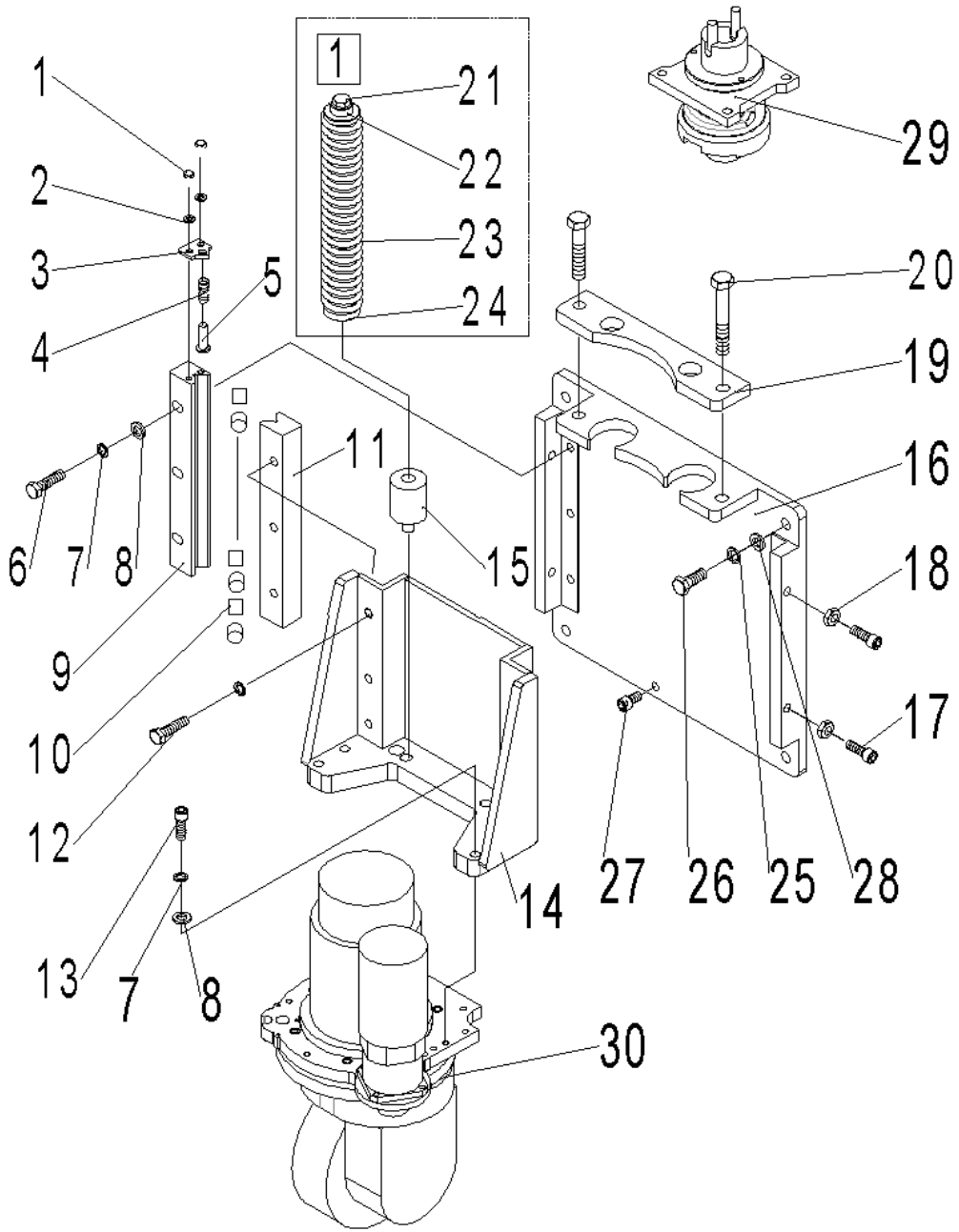

Fig. 18 Electric power assisted steering wheel carrier

No.	Art No.	Item	Qty.	Note	Standard
1	0000023042	Screw	8	M6×10	GB/T70.1=ISO4762
2	0000025010	Washer	8	6	GB/T93
3	2000202006	End cover	4		
4	2000231001	Spring	4		
5	2000207001	Spring spindle	4		
6	0000023099	Screw	6	M10×45	GB/T70.1=ISO4762
7	0000023006	Washer	18	10	GB/T93
8	0000025002	Washer	22	10	GB/T95
9	2000202004	V type outer block	2		
10	2000202008	Roller	24		
11	9000007685	V type inner block	2		
12	0000023025	Screw	6	M10×40	GB/T70.1=ISO4762
13	0000023099	Screw	6	M10×45	GB/T70.1=ISO4762
14	9000007680	Wheel carrier welding	1		
15	2000202003	Cushion block	2		
16	2000201004	Supporting frame welding	1		
17	0090000602	Screw	4	M10×25	GB/T821
18	0000024012	Thin nut	4	M10	GB/T6172.1=ISO4035
19	2000202002	Top plate	1		
20	0000023095	Bolt	2	M14×60	GB/T5783=ISO4017
21	2000223001	Screw	2	M10×180	
22	2000208001	Spring guide sleeve	2		
23	2000231002	Spring	2		
24	2000212001	Spring guide rod	2		
25	0000025024	Washer	4	12	GB/T93
26	0000023094	Screw	4	M12×30	GB/T70.1=ISO4762
27	0000023098	Screw	1	M12×10	GB/T70.1=ISO4762
28	0000025032	Washer	4	12	GB/T95
29	9000007686	Electronic steering assembly	1		
30	9000007779	Drive wheel assembly	1		
①	2000200003	Spring assembly	2		

Fig. 19 Electric steering assembly

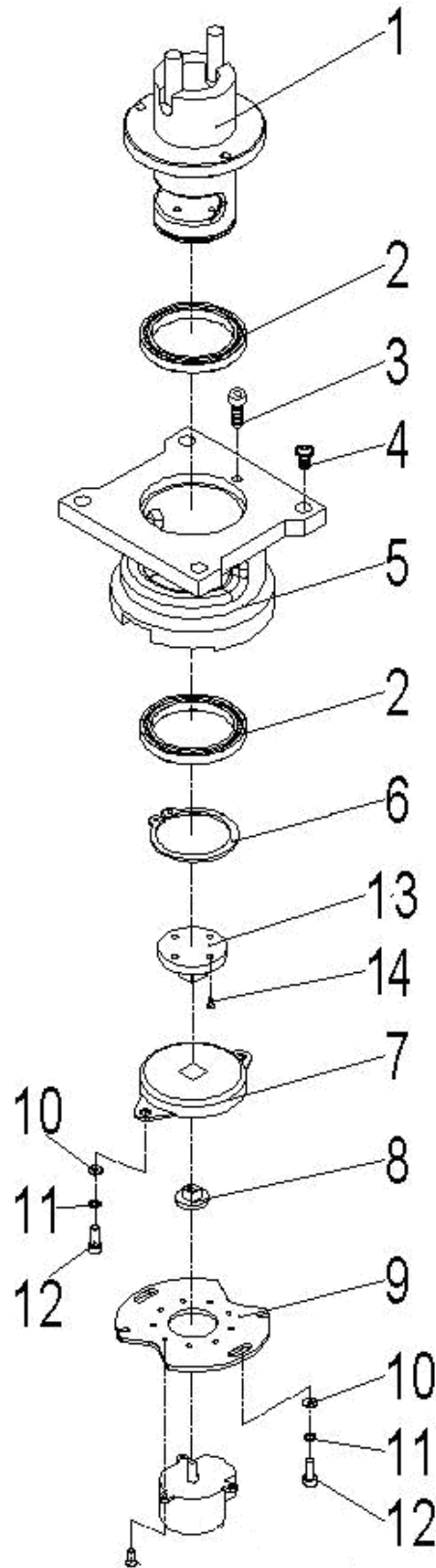

Fig. 19 Electric steering assembly

No.	Art No.	Item	Qty.	Note	Standard
1	9000007422	Bearing seat welding	1		
2	9000000240	Ball bearing	2	65x50x7	GB/T276
3	0000023042	Screw	3	M6x10	GB/T70.1=ISO476
4	0000023034	Screw	4	M10x20	GB/T70.1=ISO476
5	9000007423	Fixing seat welding	1		
6	0000026043	Retainer ring for shaft	1	50	GB/T894.1
7	9000007806	Damper	1		
8	9000007421	Transition linking block	1		
9	9000007693	Potentiometer fixing plate	1		
10	0000023032	Washer	4	5	GB/T95
11	0000025015	Washer	4	5	GB/T93
12	0000023311	Screw	4	M5x10	GB/T70.1=ISO476
13	9000007424	Linking block	1		
14	0000023073	Screw	4	M4x10	GB/T70.1=ISO476

Fig. 20 7EL-AC-1.3 Drive wheel assembly

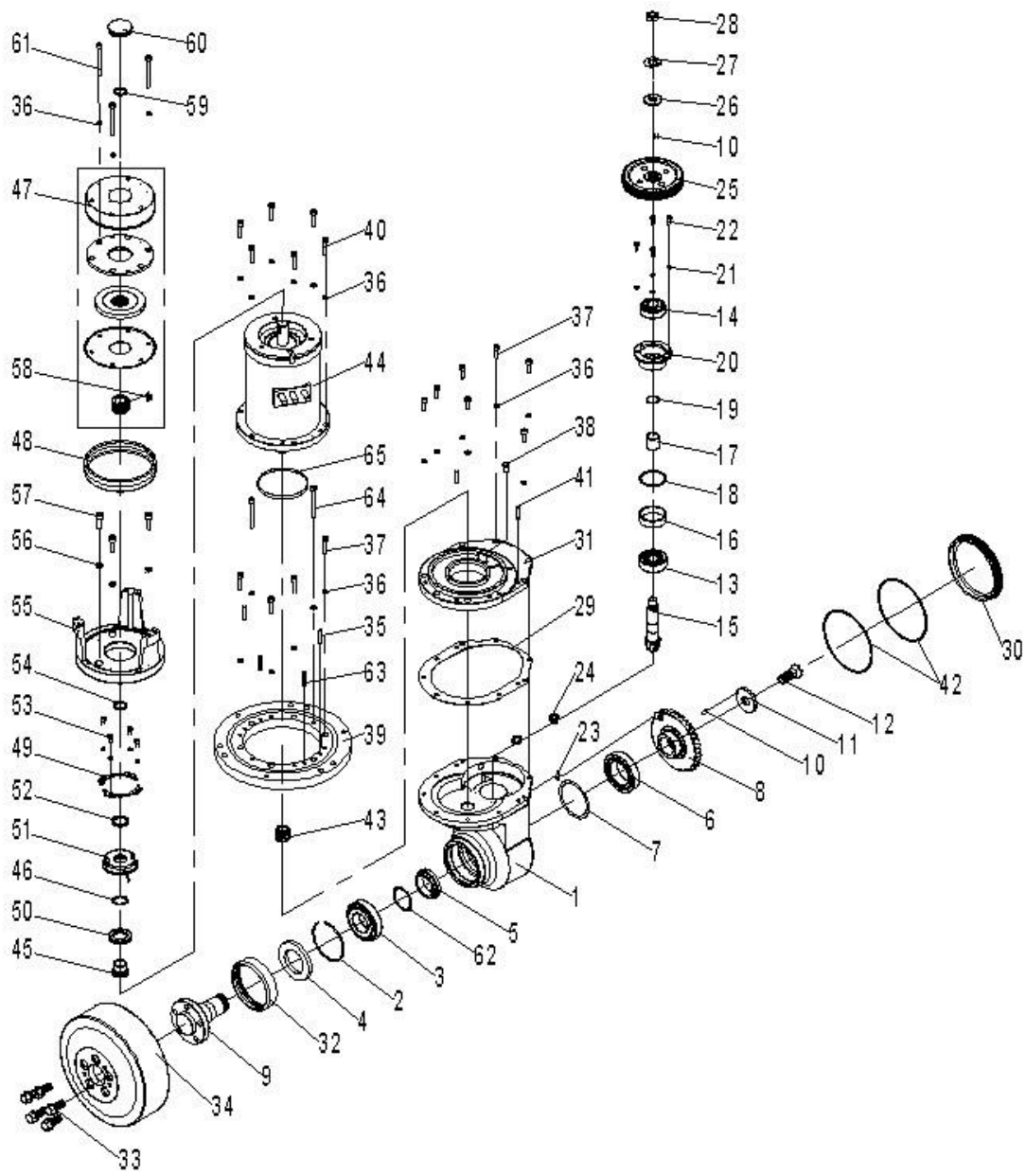

Fig. 20 7EL-AC-1.3 Drive wheel assembly

No.	Art No.	Description	Qty.	Note	Standard
1	9000009493	Gear box	1		
2	9000009494	Retainer ring	1		
3	0090000116	Bearing	1	30208	GB/T297
4	0090000505	Oil seal	1	50×80×8	GB/T9877
5	9000009496	Bushing	1		
6	0000027031	Bearing	1	32010	GB/T297
7	9000009497	Adjusting washer	1		
8	9000009498	Gear	1		
9	9000009499	Drive wheel	1		
10	0090000117	Roll pin	2	4×12	GB/T119.1=ISO2338
11	9000009500	Retainer ring	1		
12	9000009501	Bolt	1		
13	0090000502	Bearing	1	32304	GB/T297
14	0090000503	Bearing	1	32204	GB/T297
15	9000009502	Gear	1		
16	9000009503	Outer thimble	1		
17	9000009504	Inner thimble	1		
18	9000009505	Adjusting washer	1		
19	9000009506	Adjusting washer	1		
20	9000009507	Shaft block	1		
21	0000025012	Washer	8	5	GB/T93
22	0000023675	Screw	4	M5×16	GB/T70.2=ISO7380
23	0000022036	Combination washer	3	12	JB/T982
24	0090000506	Plug	3	M12x1.25	JB/ZQ4444
25	9000009508	Big gear	1		
26	9000009509	Washer	1		
27	0000025066	Washer	1	14	GB/T856
28	0090000090	Nut	1	M14×1.5	GB/T6173=ISO8675
29	9000009510	Washer	1		
30	9000009511	Side cover	1		
31	9000009512	Upper cover	1		
32	9000009513	Dust cover	1		
33	9000009514	Bolt	5		
34	9000009515	Drive wheel	1		
35	0000028027	Roll pin	2	6×30	GB/T119.1=ISO2338

Fig. 20 7EL-AC-1.3 Drive wheel assembly

No.	Art No.	Description	Qty.	Note	Standard
36	0000025006	Washer	22	6	GB/T93
37	0000023020	Screw	11	M6×20	GB/T70.1=ISO4762
38	9000009495	Vent plug	1		
39	9000009516	Rotating support	1		
40	0000023106	Screw	6	M6×30	GB/T70.1=ISO4762
41	0090000504	Roll pin	2	6×26	GB/T119.1=ISO2338
42	0000022037	O seal ring	2	125× 2.65	GB/T3452.1=ISO3601-1
43	9000009517	Small gear	1		
44	9000009518	Drive motor	1		
45	9000009519	Shaft sleeve	1		
46	0000026013	Retainer ring for shaft	1	25	GB/T894.1
47	9000009520	Brake	1		
48	9000009521	Dust cover	1		
49	9000009522	Flange	2		
50	9000009523	Speed sensor gear	1		
51	9000009524	Speed sensor	1		
52	9000009525	Spacer	1		
53	0000023311	Screw	4	M5×10	GB/T70.1=ISO4762
54	0000022059	O seal ring	1	20× 2.65	GB/T3452.1=ISO3601-1
55	9000009526	Bracket	1		
56	0000025001	Washer	3	8	GB/T93
57	0000023047	Screw	3	M8x25	GB/T70.1=ISO4762
58	0000036003	Flat key	1	6×18	GB/T1096
59	0000026003	Retainer ring for shaft	1	20	GB/T894.1
60	9000009527	Dust cover	1		
61	0000023563	Screw	3	M6×65	GB/T70.1=ISO4762
62	9000009528	Adjusting washer	1		
63	0000028137	Roll pin	2	6×30	GB/T879.1=ISO8752
64	0090000321	Screw	2	M6×45	GB/T70.1=ISO4762
65	0000022038	O seal ring	1	65X2.65	GB/T3452.1=ISO3601-1

Fig. 21 26EL-AC-1.3KW-R Drive wheel assembly

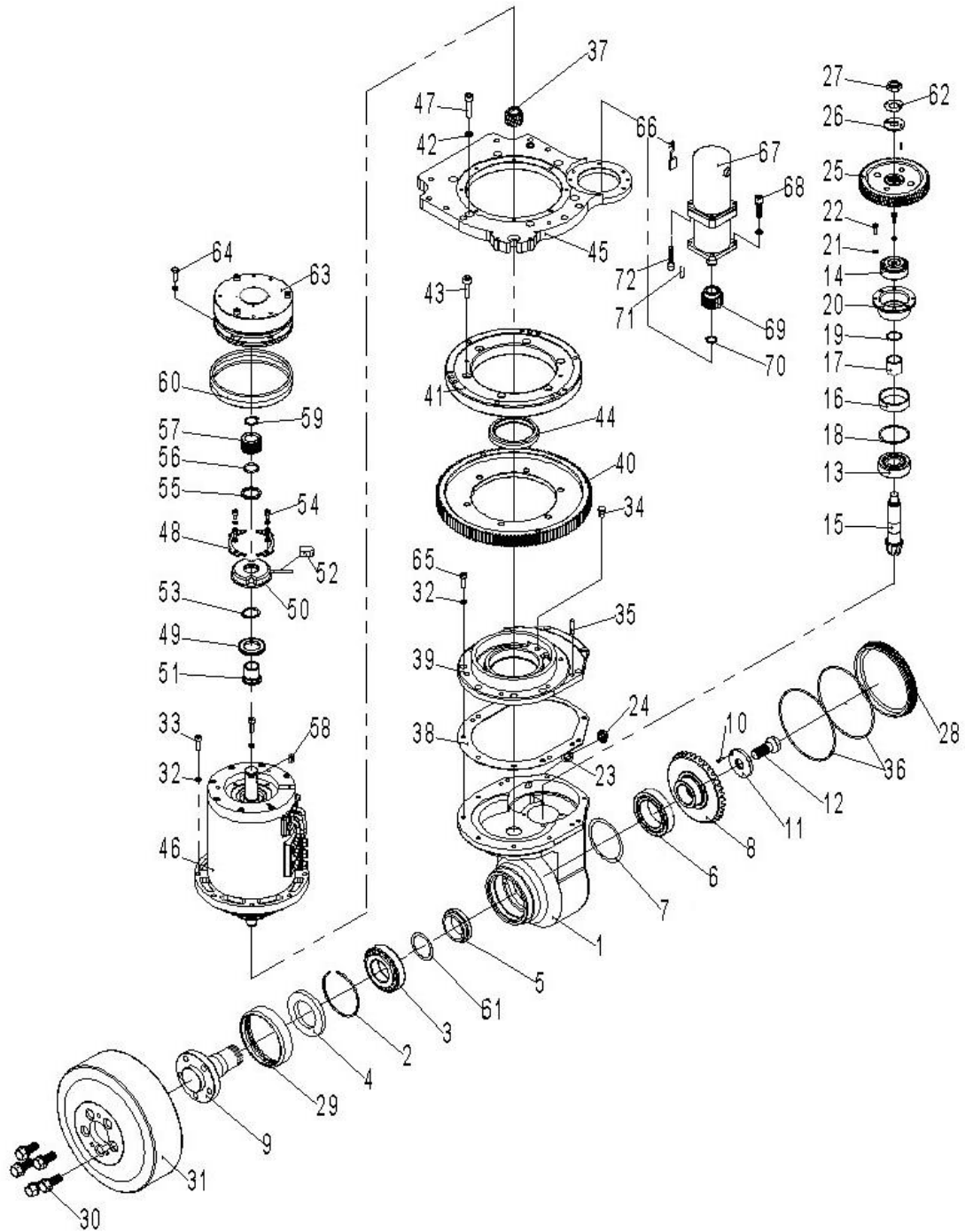

Fig. 21 26EL-AC-1.3KW-R Drive wheel assembly

No.	Art No.	Description	Qty.	Note	Standard
1	9000009493	Gear box	1		
2	9000009494	Retainer ring	1		
3	0090000116	Bearing	1	30208	GB/T297
4	0090000505	Oil seal	1	50x80x8	GB/T9877
5	9000009496	Bushing	1		
6	0000027031	Bearing	1	32010	GB/T276
7	9000009497	Adjustng washer	1		
8	9000009498	Gear	1		
9	9000009499	Drive shaft	1		
10	0090000117	Roll pin	2	4x12	GB/T119.2-2000
11	9000009500	Retainer ring	1		
12	9000009501	Locking bolt	1		
13	0090000502	Bearing	1	32304	GB/T276
14	0090000503	Bearing	1	32204	GB/T276
15	9000009502	Gear	1		
16	9000009503	Outter sleeve	1		
17	9000009504	Inner sleeve	1		
18	9000009505	Adjustng washer	1		
19	9000009506	Adjustng washer	1		
20	9000009507	Bearing seat	1		
21	0000025015	Washer	8	5	GB/T93
22	0000023107	Screw	4	M5x16	GB/T70.1=ISO4762
23	0000022036	Combination washer	3	12	JB/T982
24	0090000506	Bolt	3	M12x1.25	JB/ZQ4444-2006
25	9000009508	Big gear	1		
26	9000009509	Washer	1		
27	0090000090	Nut	1	M14x1.5	GB/T6173=ISO8675
28	9000009511	Side cover	1		
29	9000009513	Dust cover	1		
30	9000009514	Tyre bolt	5		
31	9000009515	Drive wheel	1		
32	0000025010	Washer	20	6	GB/T93
33	0000023106	Screw	8	M6x30	GB/T70.1=ISO4762
34	9000009495	Vent plug	1		
35	0090000504	Roll pin	2	6x26	GB/T119.1=ISO2338
36	0000022037	O ring	2	125x2.65	GB/T3452.1=ISO3601-1
37	9000009517	Small gear	1		

Fig. 21 26EL-AC-1.3KW-R Drive wheel assembly

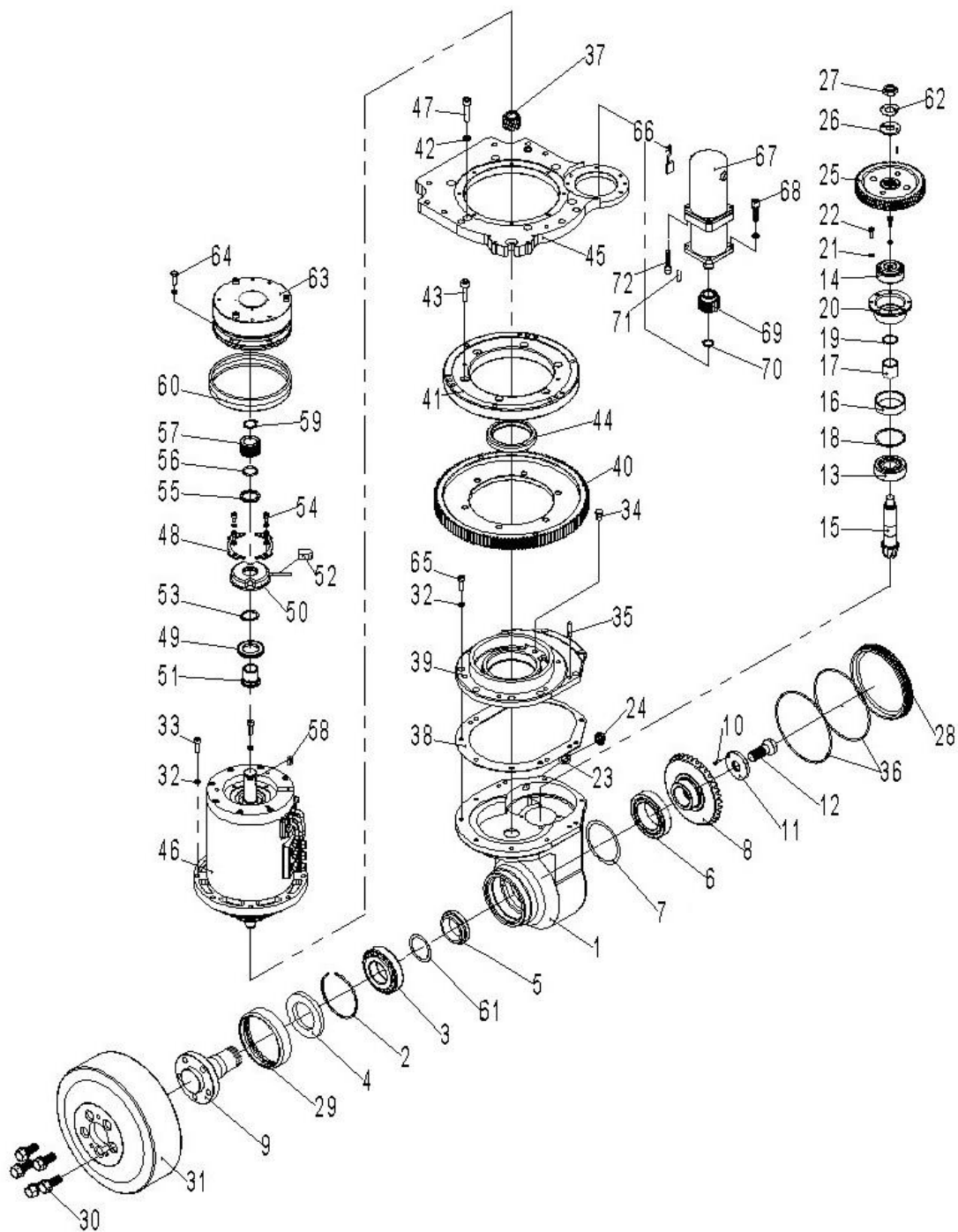

Fig. 21 26EL-AC-1.3KW-R Drive wheel assembly

No.	Art No.	Description	Qty.	Note	Standard
38	9000009824	Paper washer	1		
39	9000009825	Upper cover	1		
40	9000009826	String big gear	1		
41	9000009745	Rotating bearing	1		
42	0000025001	Washer	6	8	GB/T93
43	0000023455	Screw	6	M8x35	GB/T70.1=ISO4762
44	0090000151	Oil seal	1		GB/T9877
45	9000009532	Assembling board	1		
46	9000009827	Motor	1		
47	0000023172	Screw	6	M8x30	GB/T70.1-2000
48	9000009522	Locking flange	2		
49	9000009523	Speed sensor gear	1		
50	9000009524	Speed sensor	1		
51	9000009748	Bearing	1		
52	9000008854	Bushing	1		
53	0000026013	Retainer ring for axle	1	25	GB/T894.1
54	0000023311	Screw	4	M5x10	GB/T70.1=ISO4762
55	9000009525	spacer	1		
56	0000022059	O seal ring	1	20x2.65	GB/T3452.1=ISO3601-1
57	9000009749	Bushing	1		
58	0000036001	Flat key	1	6x16	GB/T1096
59	0000026003	Retainer ring for axle	1	20	GB/T894.1
60	9000009521	Dust cover	1		
61	9000009528	Adjustng washer	1		
62	0000025066	Washer	1	14	GB/T856
63	9000009750	Brake	1		
64	0090000526	Bolt	3	M6x20	GB/T5782=ISO4014
65	0000023020	Screw	9	M6x20	GB/T70.1=ISO4762
66	9000006304	Steering carbon brush	1		
67	9000009726	Steering motor	1		
68	0090000119	Screw	8	M6x22	GB/T70.1=ISO4762
69	9000009828	Steering small gear	1		
70	0000026040	Retainer ring for axle	1	22	GB/T894.1
71	0090000118	Flat key	1	6x28	GB/T1096
72	0000023106	Screw	12	M6x30	GB/T70.1=ISO4762

Fig. 22 Handle lever

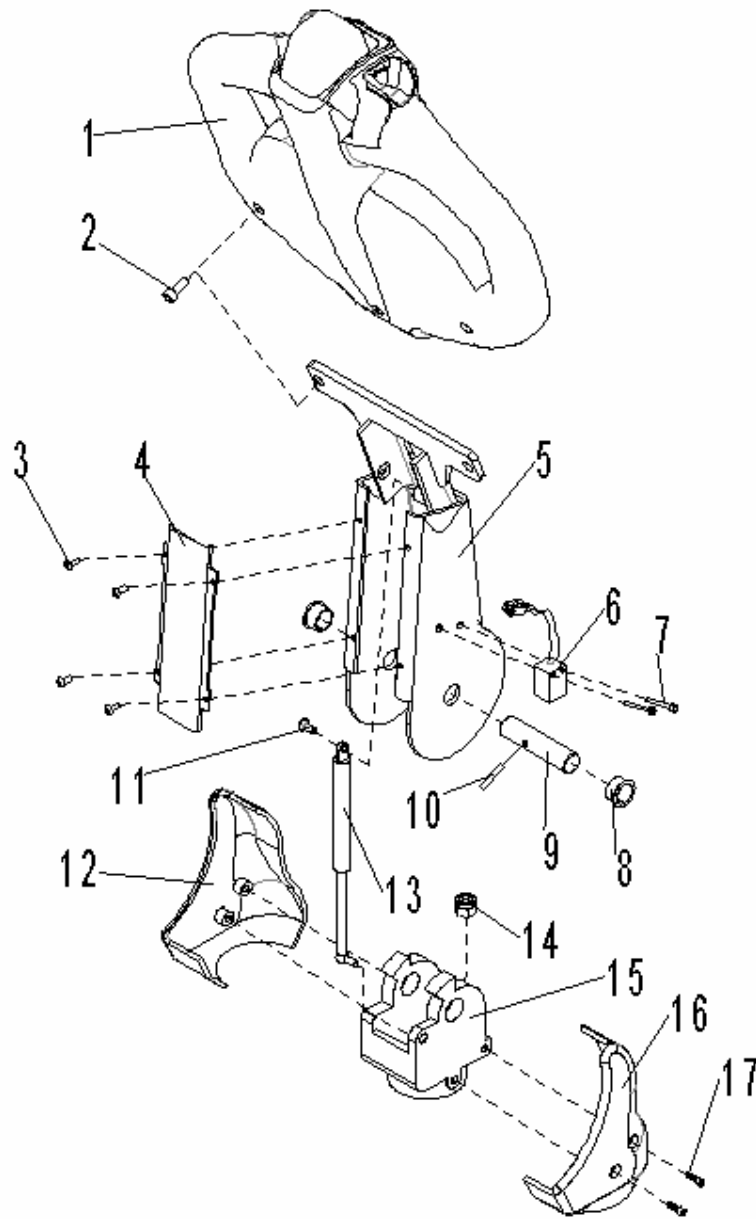

Fig. 22 Handle lever

No.	Parts No.	Item	Quantity	Note	Standard
1	1100100001	Canbus control tiller	1		
2	0000023232	Bolt	2	M8x25	GB/T5783=ISO4017
3	1000123003	Screw	4	M4x8	GB/T70.2=ISO7380
4	9000007926	Cover board	1		
5	9000007925	Welded tiller arm	1		
6	9000008327	Proximity switch	1		
7	0000023075	Screw	2	M3x20	GB/T70.1=ISO4762
8	1000113001	Shoulder harness	2	17x19x11	
9	9000007928	Tiller axle	1		
10	0000028003	Elastic roll pin	1	4x24	GB/T879.1=ISO8752
11	1000123001	Screw	1	M8x20	
12	9000007930	Left tiller cover	1		
13	1010121001	Air spring	1	400N S≥55	
14	0000023005	Lock nut	2	M10	GB/T889.1=ISO7040
15	9000007929	Tiller seat	1		
16	9000007931	Right tiller cover	1		
17	0000023519	Screw	4	M6x10	GB/T70.2=ISO7380

Fig. 23 CANBUS Handle head

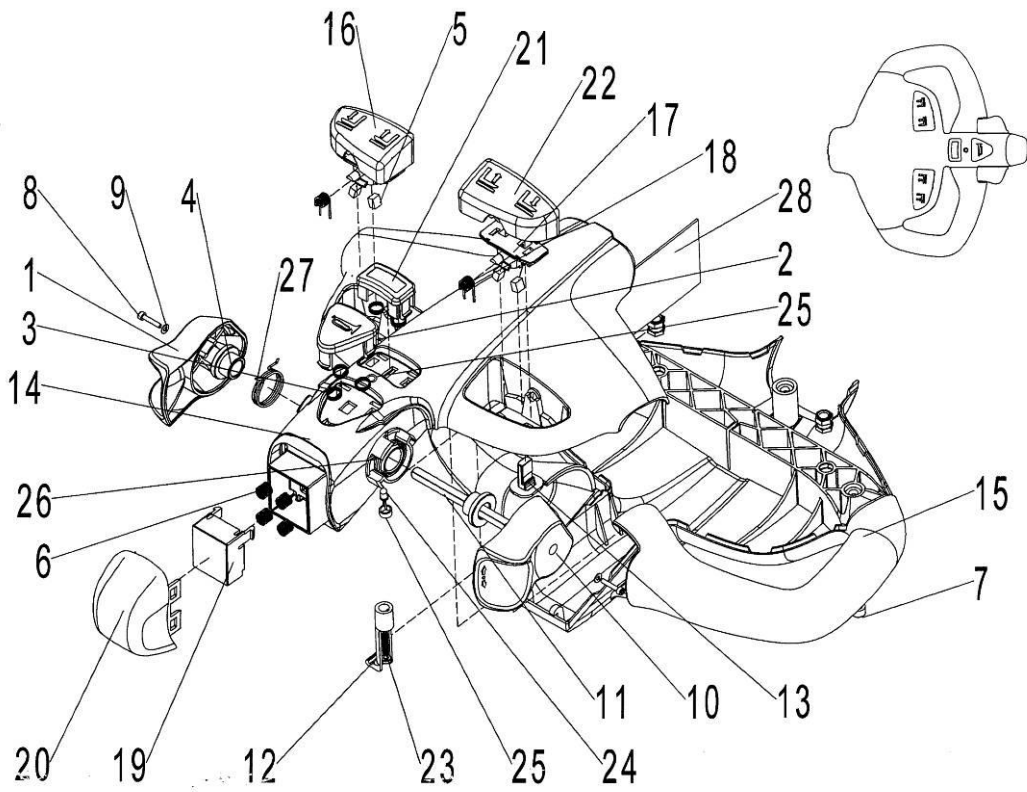

Fig. 23 CANBUS Handle head

No.	Parts No.	Item	Qty.	Note	Standard
1	1010114001	Left driving button	1		
2	1000114015	Horn button	1		
3	1000131009	Spring for horn button	5		
4	1000113004	Bushing for camshaft	2		
5	1000137001	Magnetic substance	4		
6	1000131010	Spring for urgent reversing button	4		
7	0000023058	Screw	3		GB/T70.1=ISO4762
8	0000023057	Screw	2		GB/T70.1=ISO4762
9	0000025017	Washer	2		GB/T95
10	1010114003	Right driving button	1		
11	1000107002	Shaft for driving button	1		
12	1000137002	Circlip for PCB board	1		
13	1000134005	Load censor	2		
14	1000103012	Upper part of handle	1		
15	1000103013	Under part of handle	1		
16	1000114017	Left button	1		
17	1000137003	Magnetic substance seat	2		
18	1000131011	Torsional spring	2		
19	1000114018	Seat for Spring for urgent reversing button	1		
20	1000114020	Cover for Spring for urgent reversing button	1		
21	1000114021	Cover for option switch	1		
22	1000114022	Right button	1		
23	0000023060	Screw	1		GB/T845=ISO7049
24	1000134006	LED bi-color light	1		
25	1000103014	Seat for LED bi-color light	1		
26	1000131012	Torsional spring for right driving button	1		
27	1000131013	Torsional spring for left driving button	1		
28	1100135001	PCB	1		

Fig. 24 Pump station system (3.0KW 3.2 delivery capacity)

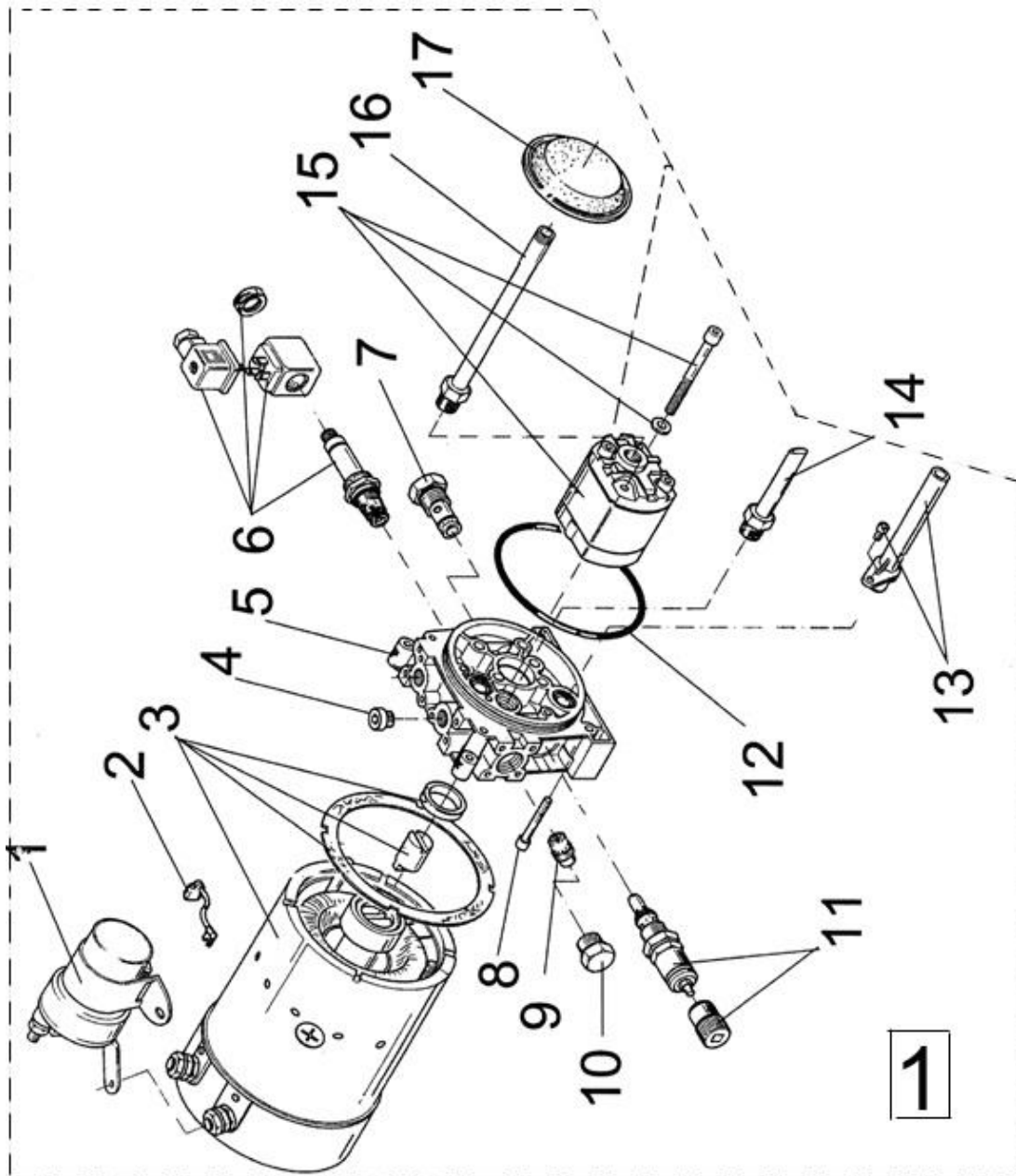

Fig. 24 Pump station system (3.0KW 3.2 delivery capacity)

No.	Parts No.	Item	Qty.	Note
1	2040334001	Pump contactor	1	
2	9000003582	Carbon brush(assembly)	1	
3	9000003583	Motor	1	
4	2000323001	Plug	1	
5	2000300002	Valve body	1	
6	2000335003	Solenoid valve	1	
7	2000335004	Check valve	1	
8	2000323002	Screw	4	
9	9000008828	Flow control valve	1	9.5L/min
10	2000323003	Bolt	1	
11	2040315003	Overflow valve	1	
12	2000322004	O ring	1	
13	2000317008	Oil return pipe	1	
14	2040317008	Oil return pipe	1	
15	9000008874	Gear pump 3.2cc/r	1	
16	9000008873	Oil suction pipe	1	L=250.50mm
17	2000300004	Filter	1	
①	9000011360	DC power unit	1	Pump Station System 3.0Kw, 3.2 delivery capacity

Fig. 25 Main circuit wiring (Electrical steering)

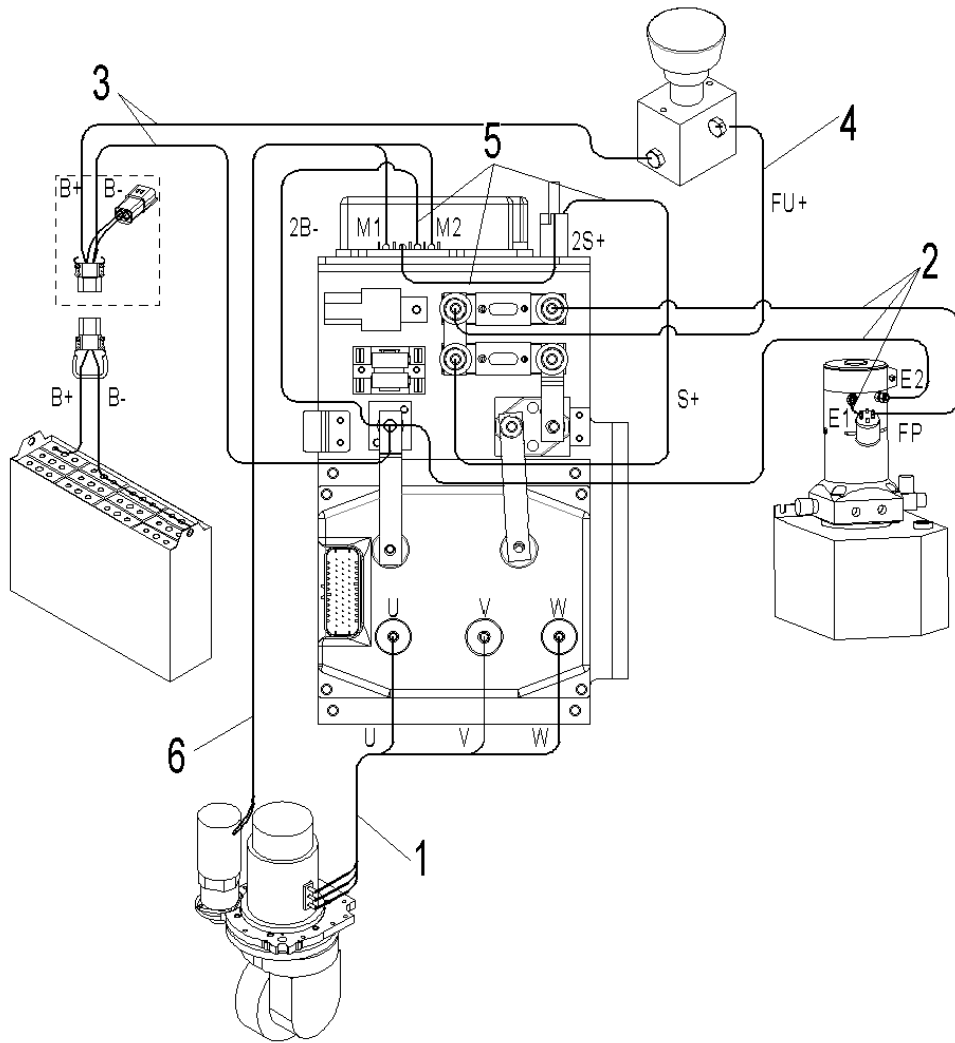

Fig. 25 Main circuit wiring (Electrical steering)

No.	Art No.	Description	Qty.	Note
1	9000008444	Drive motor cable	1	
2	9000008361	Pump motor cable	1	
3	9000008362	Power supply cable	1	
4	9000008371	FU+ cable	1	
5	9000008446	Steering controller cable	1	
6	9000008520	Steering motor cable	1	

Fig. 26 Main circuit wiring (Manual steering)

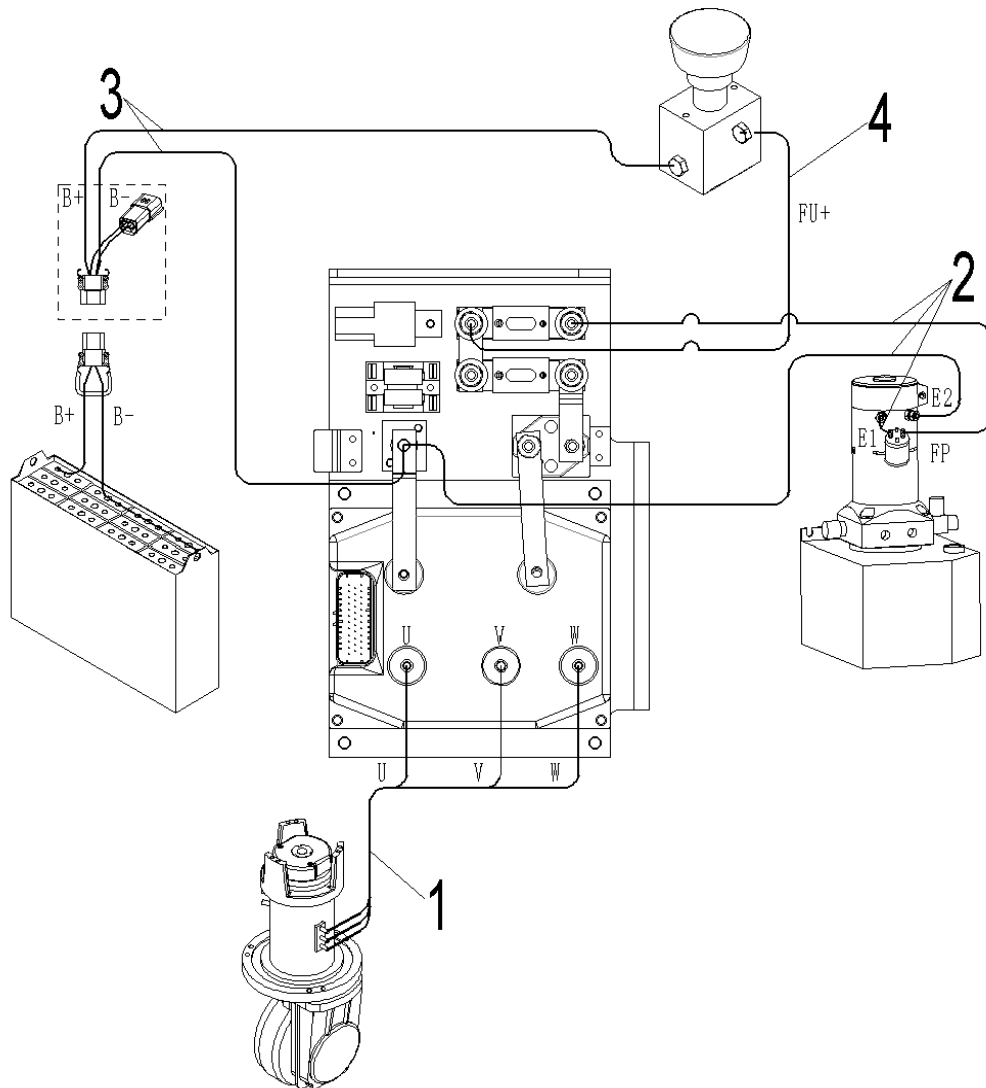

Fig. 26 Main circuit wiring (Manual steering)

No.	Art No.	Description	Qty.	Note
1	9000008368	Drive motor cable	1	
2	9000008361	Pump motor cable	1	
3	9000008362	Power supply cable	1	
4	9000008371	FU+ cable	1	

Fig. 27 General electrical parts

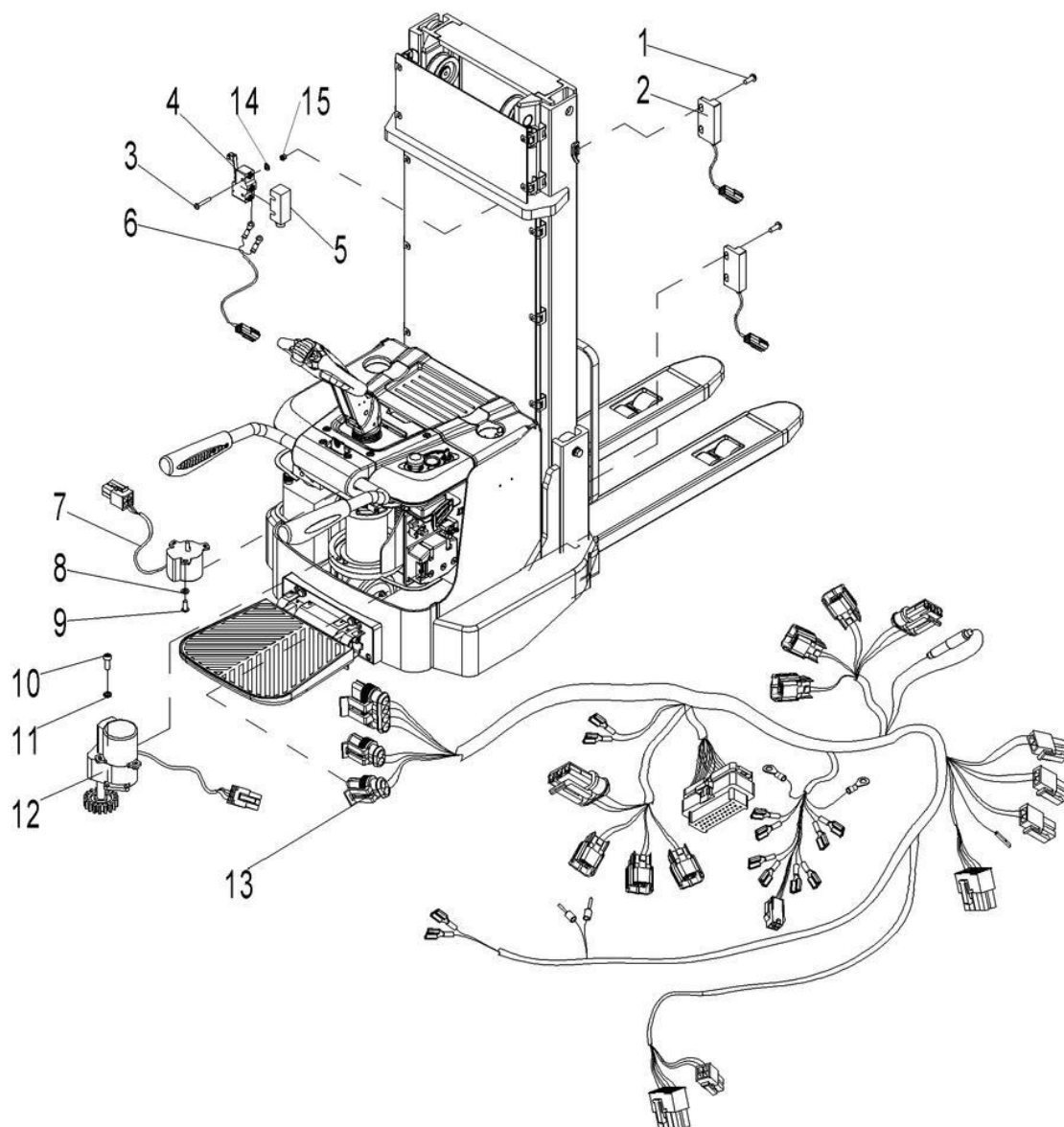

Fig. 27 General electrical parts

No.	Art No.	Description	Qty.	Note	Standard	
1	0000023083	Screw	4	M3×8	GB/T70.2=ISO7380	
2	9000008332	Magnet switch	2	HWK23		
3	0000023033	Screw	2	M4×25	GB/T70.1=ISO4762	
4	2040634001	Proximity switch	1	XZ-15GW22-B		
5	9000010040	Proximity switch protective cover AP-B	1	AP-B		
6	9000008360	Limit control wiring harness	1			
7	9000000239	Tiller sensor BD-MS-3	1	Only for electrical steering truck		
	9000008448	Tiller sensor BD-MS				
8	0000025026	Washer 3	3			GB/T95
9	0000023216	Screw M3×8	3			GB/T818-2000=ISO7045
10	0000023056	Screw M4×12	4			GB/T70.1=ISO4762
11	0000025019	Washer 4	4			GB/T95
12	9000001159	Position sensor BD-PS	1			
	9000008451	Position sensor BD-PS-3				
13	9000008355	Main control wiring harness	1		electrical steering	
	9000008359				Manual steering	
14	0000025019	Washer	2	4	GB/T95	
15	0000024004	Nut	2	M4	GB/T889.1=ISO7040	

Fig. 28 Electric control assembly(Electrical steering)

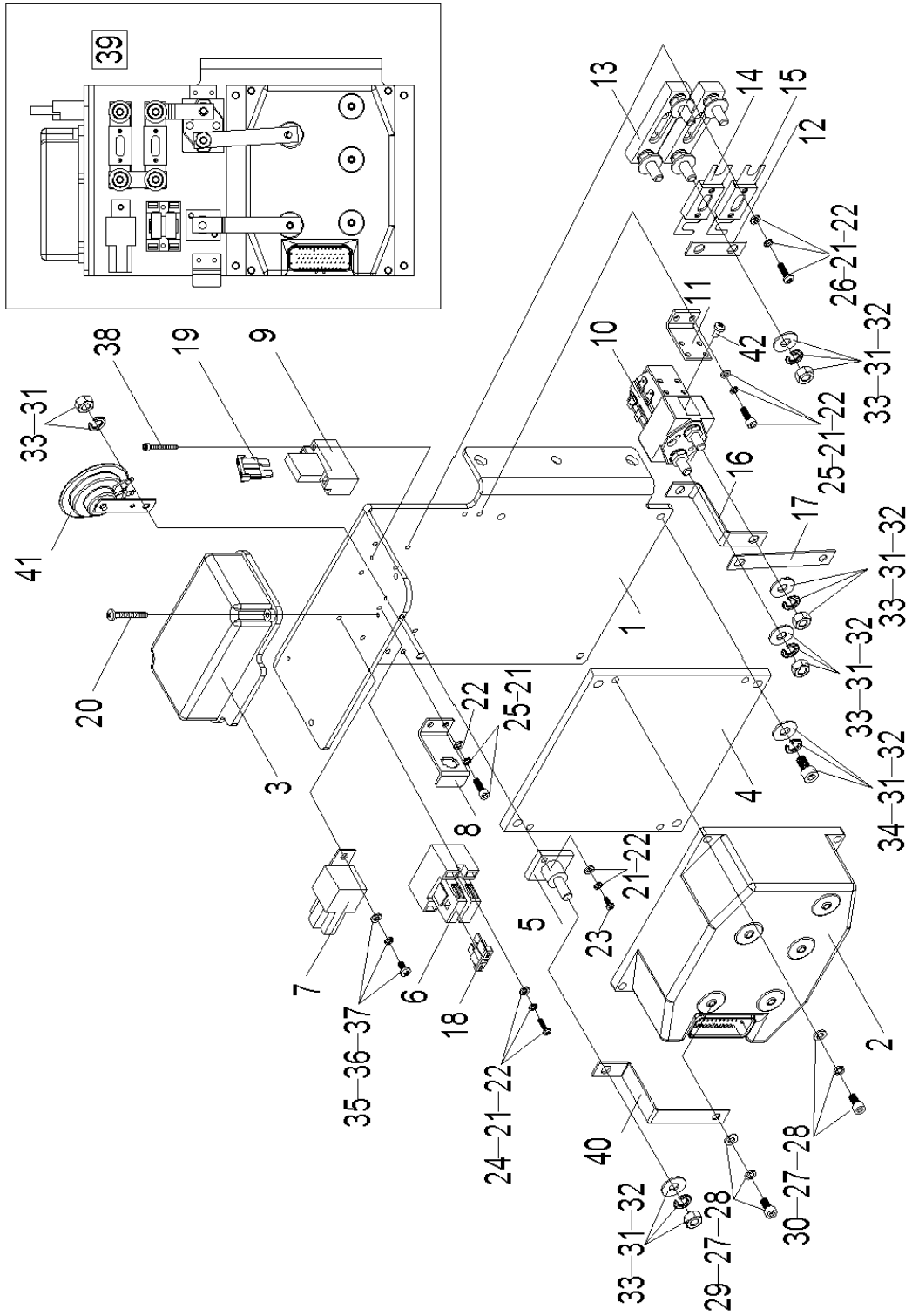

Fig. 28 Electric control assembly(Electrical steering)

No.	Art No.	Name	Qty.	Note	Standard
1	9000008069	Controller assemble plate	1		
2	9000000235	Controller	1	CURTIS1232E-2121	
3	9000000236	Steering controller	1	BD-SC-24/10	
	9000008584			BD-SC-24/10-3	
4	9000008376	Alumini um plate	1		
5	1020434002	Wiring terminal	1	BD-M8	
6	9000008586	Fuse seat	1	BD-2×10A-1	
7	1000434041	Relay	1	ACR01F-F 1C	
8	9000007679	Plug fixing plate	1		
9	1000434021	Fuse seat	1	BD-1×10A	
10	1000434006	Traction motor contactor	1	C100/120	
11	9000008598	Main contactor assembly plate	1		
12	1020434003	Copper bar	1		
13	1000434007	Fuse seat	2	SY Y	
14	1020434001	Fuse	1	200A	
15	2210434004	Fuse	1	150A	
16	9000008374	Copper bar	1		
17	9000008373	Copper bar	1		
18	1000434040	Fuse	1	10A	
19	3042434014	Fuse	1	15A	
20	0090000082	Screw	2	M4×30	GB/T70.1=ISO4762

Fig. 28 Electric control assembly(Electrical steering)

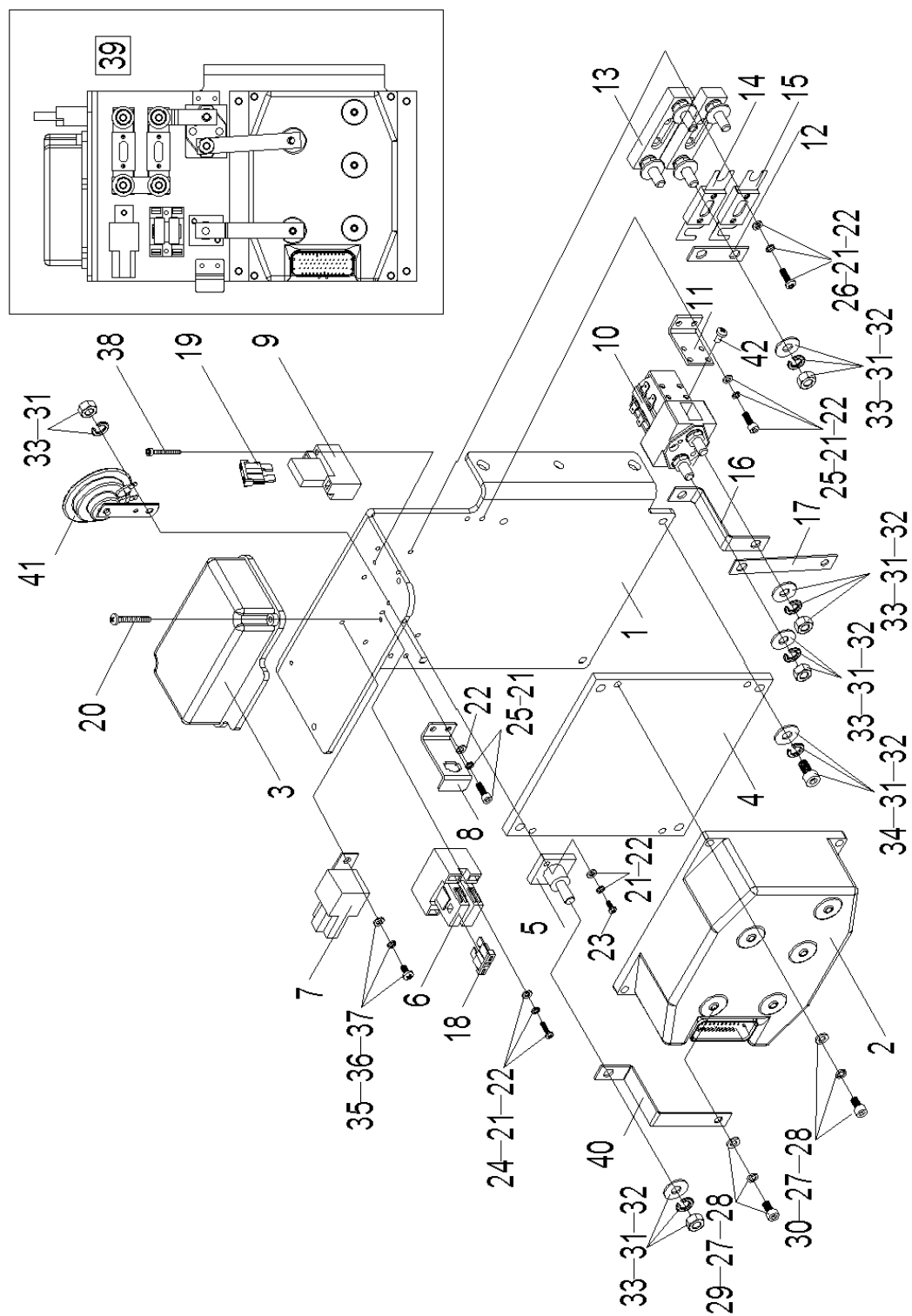

Fig. 28 Electric control assembly(Electrical steering)

No.	Art No.	Name	Qty.	Note	Standard
21	0000025018	Washer	12	4	GB/T93
22	0000025019	Washer	12	4	GB/T95
23	0000023073	Screw	2	M4×10	GB/T70.1=ISO4762
24	0000023019	Screw	2	M4×30	GB/T818-2000=ISO7045
25	0000023307	Screw	4	M4×10	GB/T818-2000=ISO7045
26	0000023211	Screw	4	M4×16	GB/T818-2000=ISO7045
27	0000025010	Washer	9	6	GB/T93
28	0000023055	Washer	9	6	GB/T95
29	0000023478	Screw	5	M6×12	GB/T70.1=ISO4762
30	0000023923	Screw	4	M6×18	GB/T70.1=ISO4762
31	0000025001	Washer	12	8	GB/T93
32	0000025011	Washer	11	8	GB/T95
33	0000024086	Nut	12	M8	GB/T6170=ISO4032
34	0000023067	Screw	4	M8×16	GB/T70.1=ISO4762
35	0000023516	Screw	1	M5×10	GB/T818-2000=ISO7045
36	0000025015	Washer	1	5	GB/T93
37	0000025014	Washer	1	5	GB/T95
38	0000023070	Screw	2	M3×25	GB/T70.1=ISO4762
39	9000008356	Controller components	1		
40	9000008372	Copper bar	1		
41	1000434015	Horn	1	DC24V	
42	0000023727	Screw	2	M4×6	GB/T818-2000=ISO7045

Fig. 29 Electric control assembly(Manual steering)

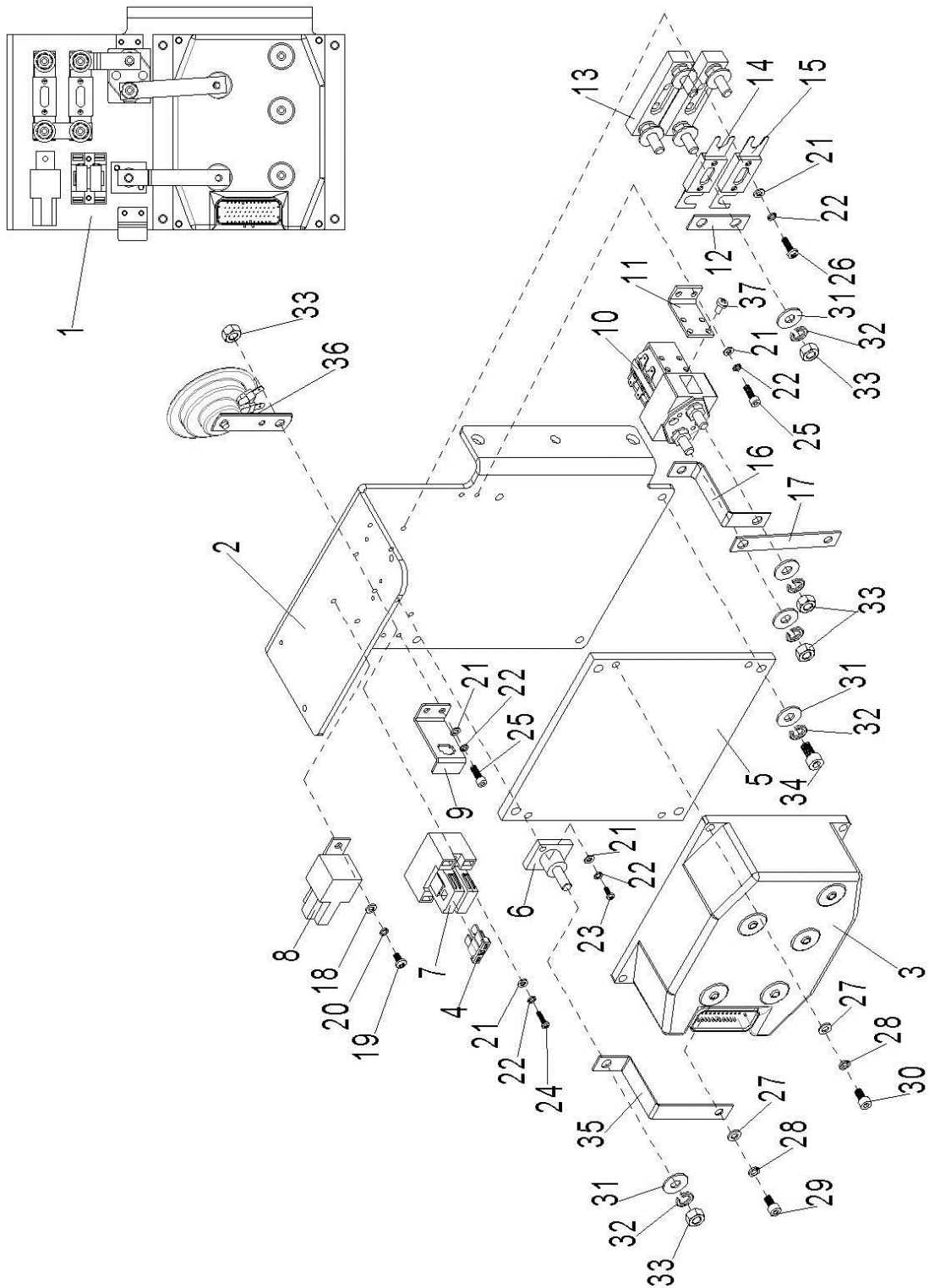

Fig. 29 Electric control assembly(Manual steering)

No.	Art No.	Name	Qty.	Note	Standard
1	9000008375	Controller	1		
2	9000008069	Controller assembly plate	1		
3	9000000235	Controller	1	CURTIS1232E-2121	
4	1000434040	Fuse	1	10A	
5	9000008376	Aluminium plate	1		
6	1020434002	Wiring terminal	1	BD-M8	
7	9000008586	Fuse seat	1	BD-2×10A-1	
8	1000434041	Relay	1	ACR01F-F 1C DC24V	
9	9000007679	Plug fixing plate	1		
10	1000434006	Traction motor contactor	1	C100/120 DC24V	
11	9000008598	Main contactor assemble plate	1		
12	1020434003	Copper bar	1		
13	1000434007	Fuse seat	2	SYF	
14	1020434001	Fuse	1	200A	
15	2210434004	Fuse	1	150A	
16	9000008374	Copper bar	1		
17	9000008373	Copper bar	1		
18	0000025014	Washer	1	5	GB/T95
19	0000023516	Screw	1	M5×10	GB/T818-2000=ISO O7045
20	0000025015	Washer	1	5	GB/T93
21	0000025018	Washer	12	4	GB/T93
22	0000025019	Washer	12	4	GB/T95
23	0000023073	Screw	2	M4×10	GB/T70.1=ISO476 2
24	0000023019	Screw	2	M4×30	GB/T818-2000=ISO O7045
25	0000023307	Screw	4	M4×10	GB/T818-2000=ISO O7045

Fig. 29 Electric control assembly(Manual steering)

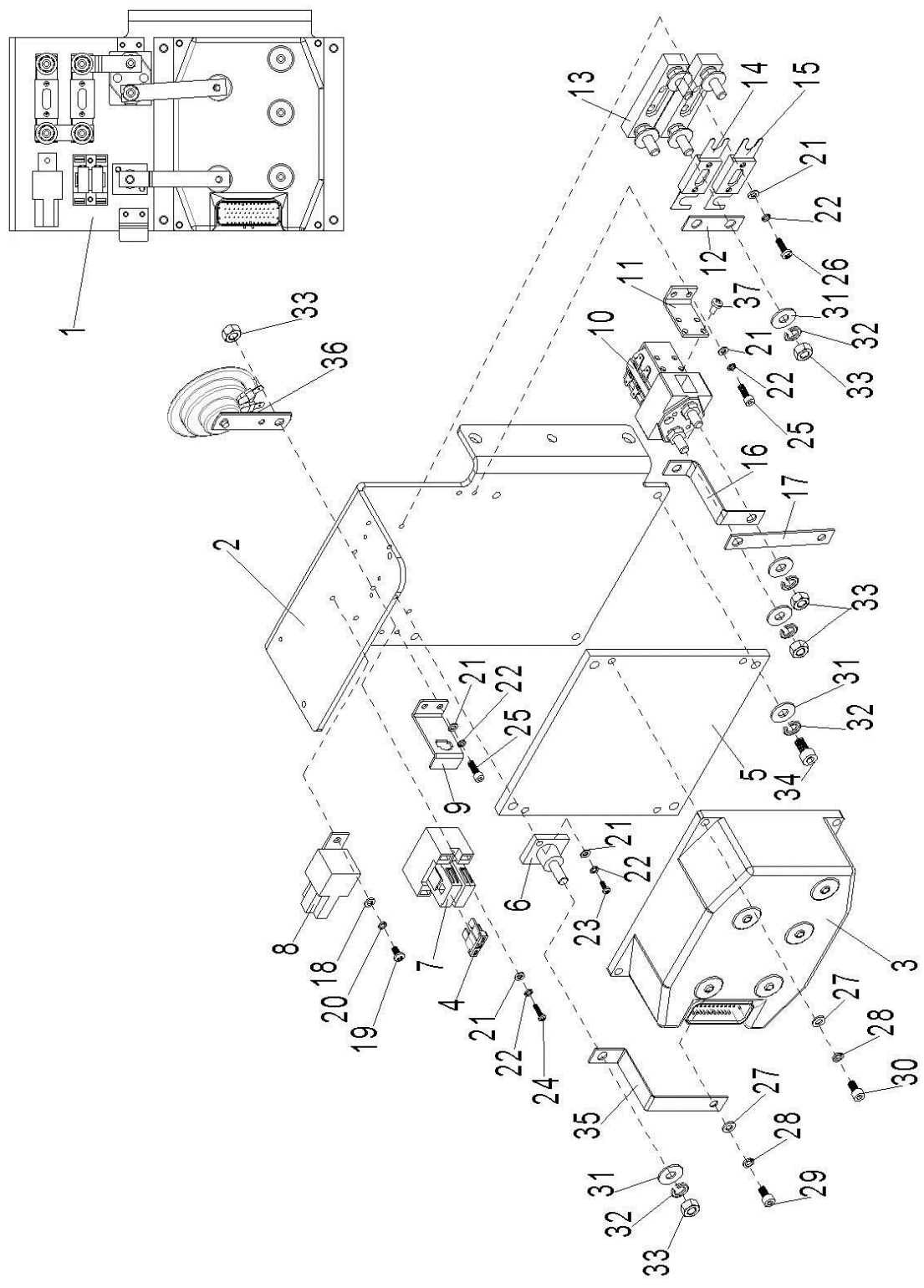

Fig. 29 Electric control assembly(Manual steering)

No.	Art No.	Name	Qty.	Note	Standard
26	0000023211	Screw	4	M4×16	GB/T818-2000=ISO O7045
27	0000025010	Washer	9	6	GB/T93
28	0000023055	Washer	9	6	GB/T95
29	0000023478	Screw	5	M6×12	GB/T70.1=ISO476 2
30	0000023923	Screw	4	M6×18	GB/T70.1=ISO476 2
31	0000025001	Washer	12	8	GB/T93
32	0000025011	Washer	11	8	GB/T95
33	0000024086	Nut	12	M8	GB/T6170=ISO40 32
34	0000023067	Screw	4	M8×16	GB/T70.1=ISO476 2
35	9000008372	Copper bar	1		
36	1000434015	Horn	1	DC24V	
37	0000023727	Screw	2	M4×6	GB/T818-2000=ISO O7045

Fig. 30 Foldable platform

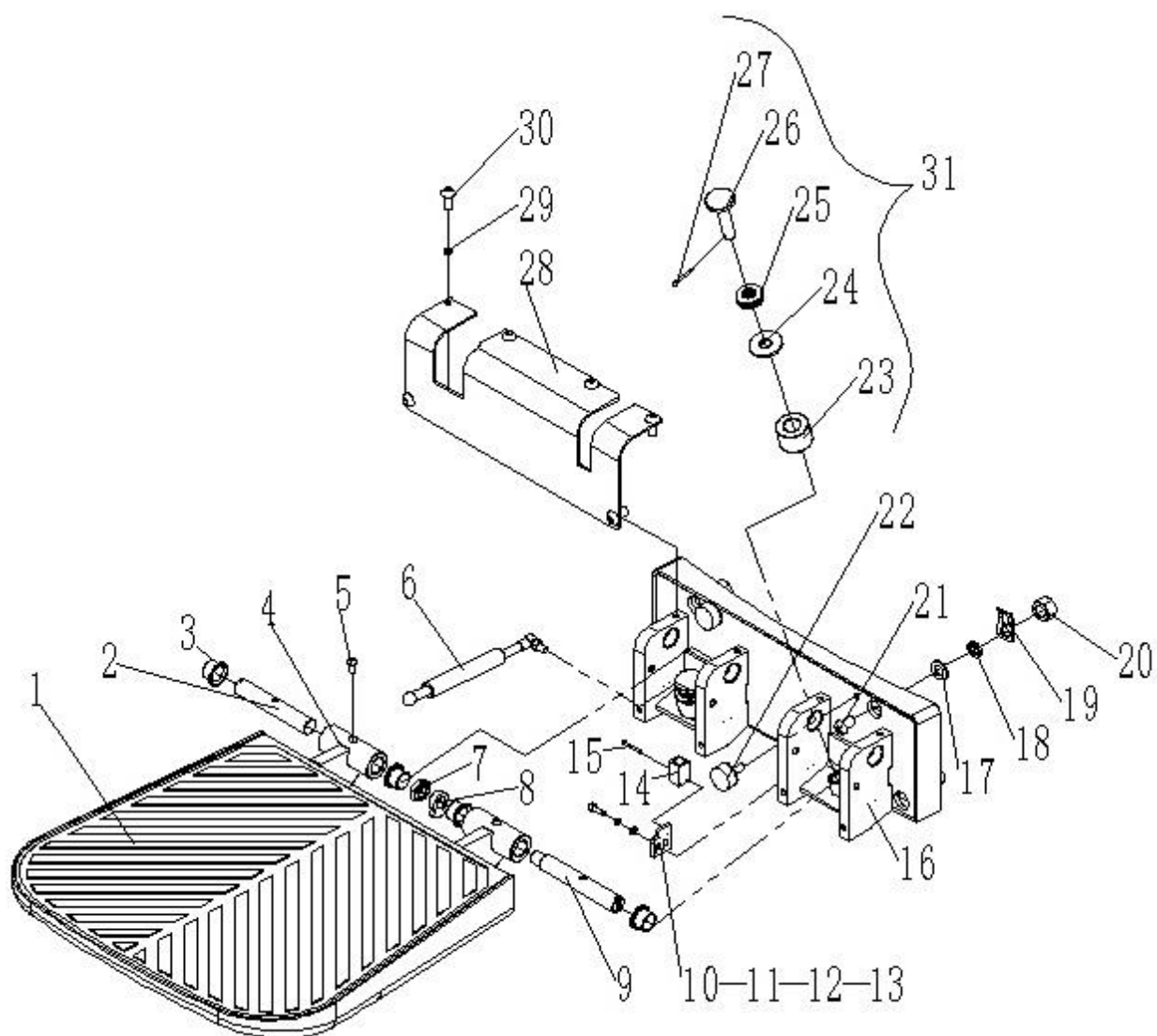

Fig. 30 Foldable platform

No.	Art No.	Description	Qty.	Note	Standard
1	9000007867	Pedal pad	1		
2	9000007869	Rotating shaft	1		
3	9000007799	Shoulder harness	4	20×23×16.5	
4	9000007863	Welded foot platform	1		
5	0000023555	Screw	2	M6×16	GB/T70.2=ISO7380
6	2000421001	Air spring	1		
7	0000024014	Nut	1	M16×1.5	GB/T6173=ISO8675
8	9000007873	Cam	1		
9	9000007866	Cam shaft	1		
10	0000025012	Washer	2	5	GB/T93
11	0000023032	Washer	2	5	GB/T95
12	0000023107	Screw	2	M5×16	GB/T70.1=ISO4762
13	9000009799	Switch transition plate	1		
14	9000008328	Proximity switch	1	NBN5-F7-E2	
15	0000023075	Screw	2	M3×20	GB/T70.1=ISO4762
16	9000007864	Welded assemble seat	1		
17	0090000048	Washer	4	12	GB/T97.1-2002
18	0000025024	Washer	4	12	GB/T93
19	9000007874	Line hanging board	1		
20	0000024006	Lock nut	4	M12	GB/T889.1=ISO7040
21	00900000450	Screw	4	M12×45	GB/T70.2=ISO7380
22	9000007865	Cushion	2		
23	9000007872	Anti-vibration pad	2		
24	9000007871	Anti-vibration washer	2		
25	0000031001	Spring	8	16.3×31.5×1.75	GB/T1972-2005
26	9000007870	Fixed bolt	2		
27	0000028033	Split pin	2	3.2×20	GB/T91=ISO1234
28	9000007868	Assemble seat cover	1		
29	0000025010	Washer	6	6	GB/T93
30	0000023045	Screw	6	M6×12	GB/T70.2=ISO7380
31	9000008897	Suspension components	2		

Fig. 31 Protective arm

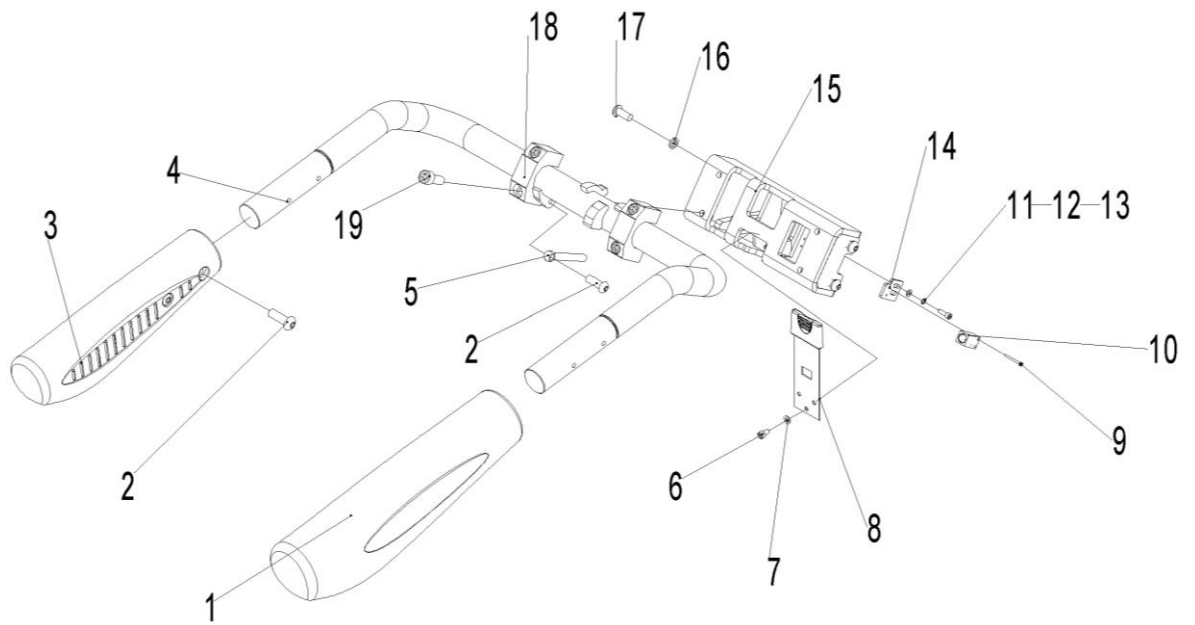

Fig. 31 Protective arm

No.	Art No.	Description	Qty.	Note	Standard
1	9000007895	Right protective arm cover	1		
2	0090000448	Screw	5	M8×20	GB/T70.2=ISO7380
3	9000007896	Left protective arm cover	1		
4	9000007894	Welded protective arm	1		
5	9000007780	Air spring	1		
6	0000023045	Screw	3	M6×12	GB/T70.2=ISO7380
7	0000025010	Washer	3	6	GB/T93
8	9000007897	Positioning spring	1		
9	0000023075	Screw	2	M3×20	GB/T70.1=ISO4762
10	9000008329	Proximity switch	1	NBN5-F7-E2	
11	0000025012	Washer	2	5	GB/T93
12	0000023032	Washer	2	5	GB/T95
13	0000023107	Screw	2	M5×16	GB/T70.1=ISO4762
14	9000009799	Switch transition plate	1		
15	9000007892	Welded protective arm seat	1		
16	0000023006	Washer	4	10	GB/T93
17	0090000447	Screw	4	M10×25	GB/T70.2=ISO7380
18	9000007893	Protective arm clamp block	2		
19	0000023099	Screw	4	M10×45	GB/T70.1=ISO4762

Fig. 32 Backrest

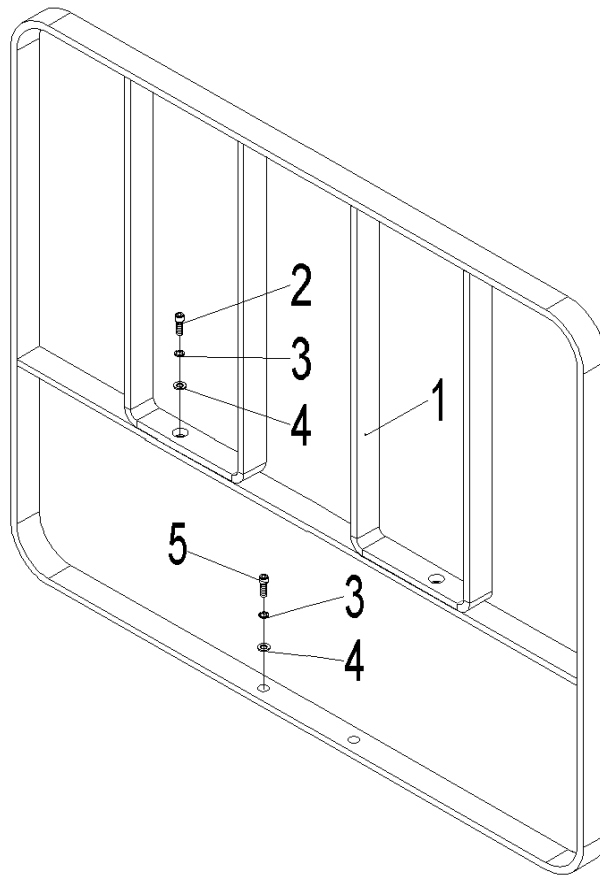

Fig. 32 Backrest

No.	Parts No.	Name	Qty.	Note	Standard
1	9000008259	Backrest frame welding	1		
2	0000023088	Screw	2	M10x25	GB/T70.1=ISO4762
3	0000025002	Washer	4	10	GB/T95
4	0000023006	Standard spring washer	4	10	GB/T93
5	0000023029	Screw	2	M10x35	GB/T70.1=ISO4762

Easy worn parts list

No.	Art No.	Description	Qty.	Fig./Position	Note
1	3500100005	Compound roller	4	Fig. 4/1	Chassis
2	9000010408	Steering wheel kit	2	Fig. 5/13	Chassis system
3	9000003638	Castor wheel	2	Fig. 6/13	Steering wheel assembly
4	9000010727	Wheel set kit	4	Fig. 7/7	Load wheel assembly (tandem roller)
5	3500100004	Compound roller	4	Fig. 12/1	Mast system
6	9000010750	Cylinder seal kit	2	Fig. 16/13	Cylinder
7	9000007806	Damper	1	Fig. 19/7	Electric steering assembly
8	1010121001	Air spring (S≥55)	1	Fig. 22/13	Handle lever
9	9000003582	Carbon brush	1	Fig. 24/2	Pump station system (3.0KW 3.2 delivery capacity)
10	1020434001	Fuse 200A	1	Fig. 28/14	Electric control assembly(Electrical steering)
11	2210434004	Fuse 150A	1	Fig. 28/15	
12	1000434040	Fuse 10A	1	Fig. 28/18	
13	3042434014	Fuse 15A	1	Fig. 28/19	
14	1000434040	Fuse 10A	1	Fig. 29/4	Electric control assembly(Manual steering)
15	1020434001	Fuse 200A	1	Fig. 29/14	
16	2210434004	Fuse 150A	1	Fig. 29/15	
17	9000007799	Shoulder harness 20x23x16.5	4	Fig. 30/3	Foldable platform
18	2000421001	Air spring	1	Fig. 30/6	
19	9000008897	Suspension components	2	Fig. 30/31	
20	9000007780	Air spring	1	Fig. 31/5	Protective arm