

SPAREPARTS LIST

Electric Stacker PT20/25N

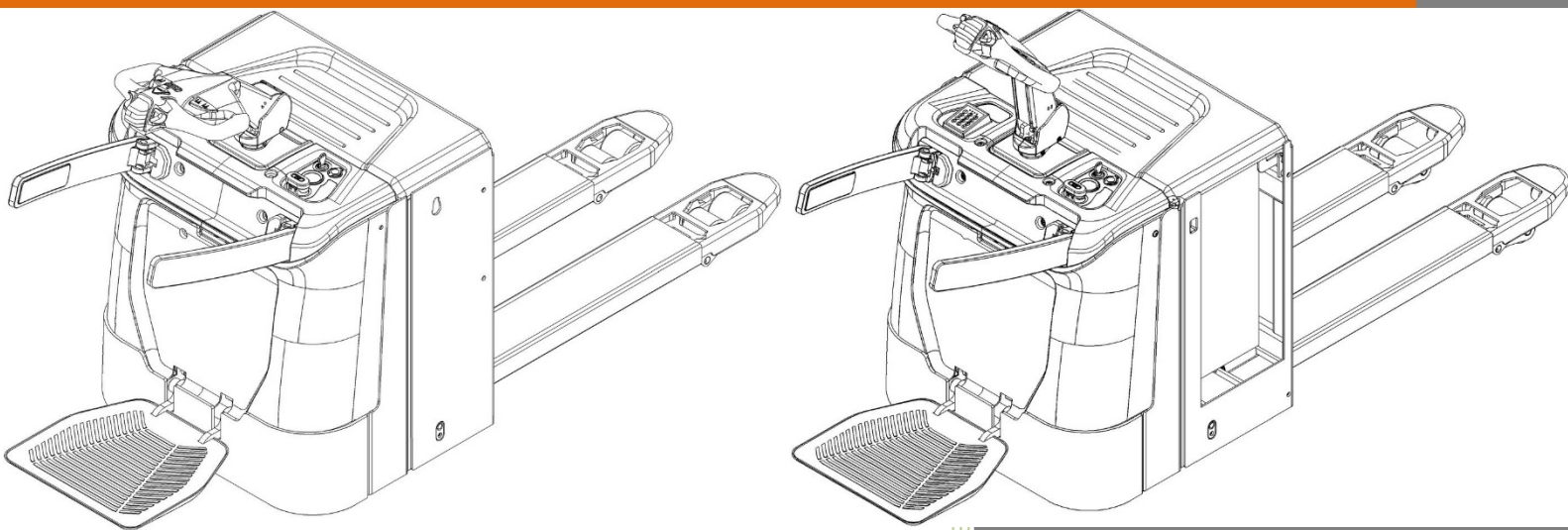

Version 05/2018

From truck identification number:

20180500013

PT 20/25N-BPT-001-EN

Catalogue

Fig. 1 PT20N Chassis	3
Fig. 2 PT20N Chassis (sideways)	5
Fig. 3 PT25N Chassis (sideways)	7
Fig. 4 Load roller components	9
Fig. 5 Driving system (Manual steering).....	11
Fig. 6 Driving assembly (Manual steering).....	12
Fig. 7 Driving system (EPS).....	14
Fig. 8 Driving assembly (EPS)	16
Fig. 9 Steering wheel components.....	18
Fig. 10 PT20N Hydraulic system	20
Fig. 11 PT25N Hydraulic system.....	22
Fig. 12 PT20N Pump station.....	24
Fig. 13 PT25N Pump station.....	26
Fig. 14 Cylinder components	28
Fig. 15 Tiller assembly	29
Fig. 16 Tiller components.....	31
Fig. 17 Outer appearance	33
Fig. 18 Battery cover components	35
Fig. 19 Load backrest assembly	36
Fig. 20 Load backrest assembly (sideways)	37
Fig. 21 Platform assembly	38
Fig. 22 Protective arm assembly.....	40
Fig. 23 EPS components	42
Fig. 24 Manual steering components.....	44
Fig. 25 Electrical box components	46
Fig. 26 Electrical parts	48
Fig. 27 PT20N Battery components (External charger)	49
Fig. 28 PT20N Battery components (Built-in charger).....	51
Fig. 29 PT25N Battery components	53
Fig. 30 Panel components	55
Fig. 31 Electrical control components (Manual steering)	57
Fig. 32 Electrical control components (EPS).....	59
Fig. 33 Main circuit (Manual steering)	61
Fig. 34 Main circuit (EPS)	62

Fig. 35 PT20N Sticker.....63
Fig. 36 PT25N Sticker.....64
Easy worn parts list.....65

Fig. 1 PT20N Chassis

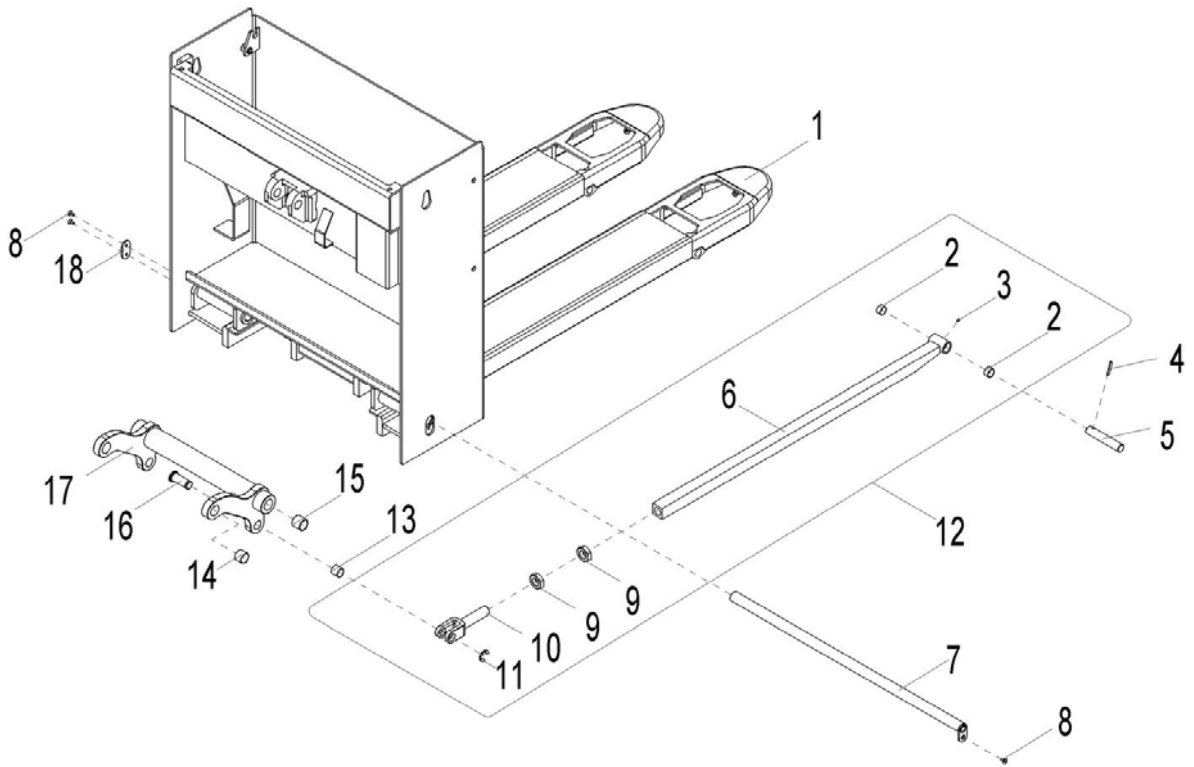

Fig. 1 PT20N Chassis

No.	Art No.	Description	Qty.	Note
1	506738510000	Chassis welding	1	540x1150
	506738510008	Chassis welding	1	685x1220
2	940500100012	Bushing	4	20x22x12
3	911200100001	Grease nipple	2	6
4	910600500004	Dowel pin	2	5x35
5	505638520038	Frame of roller axle	2	20x163
6	506738510001	Push rod welding	2	1150
	506738510009	Push rod welding	2	1220
7	506738510006	Plate with axle	1	25x774
8	910200400016	Screw	3	M6x12
9	910300400010	Nut	4	M24x1.5
10	505638520035	Push rod fork	2	
11	910401700005	Circlip	2	15
12	506798510000	Push rod kits	2	1150
	506798510001	Push rod kits	2	1220
13	940500100019	Bushing	2	20x23x20
14	940500100027	Bushing	2	25x28x20
15	940500100032	Bushing	2	25x29x25
16	505638520034	Short axle	2	20x51
17	505638510001	Rock arm welding	1	540
	505638510007	Rock arm welding	1	685
18	505638520031	Fixing plate	1	

Fig. 2 PT20N Chassis (sideways)

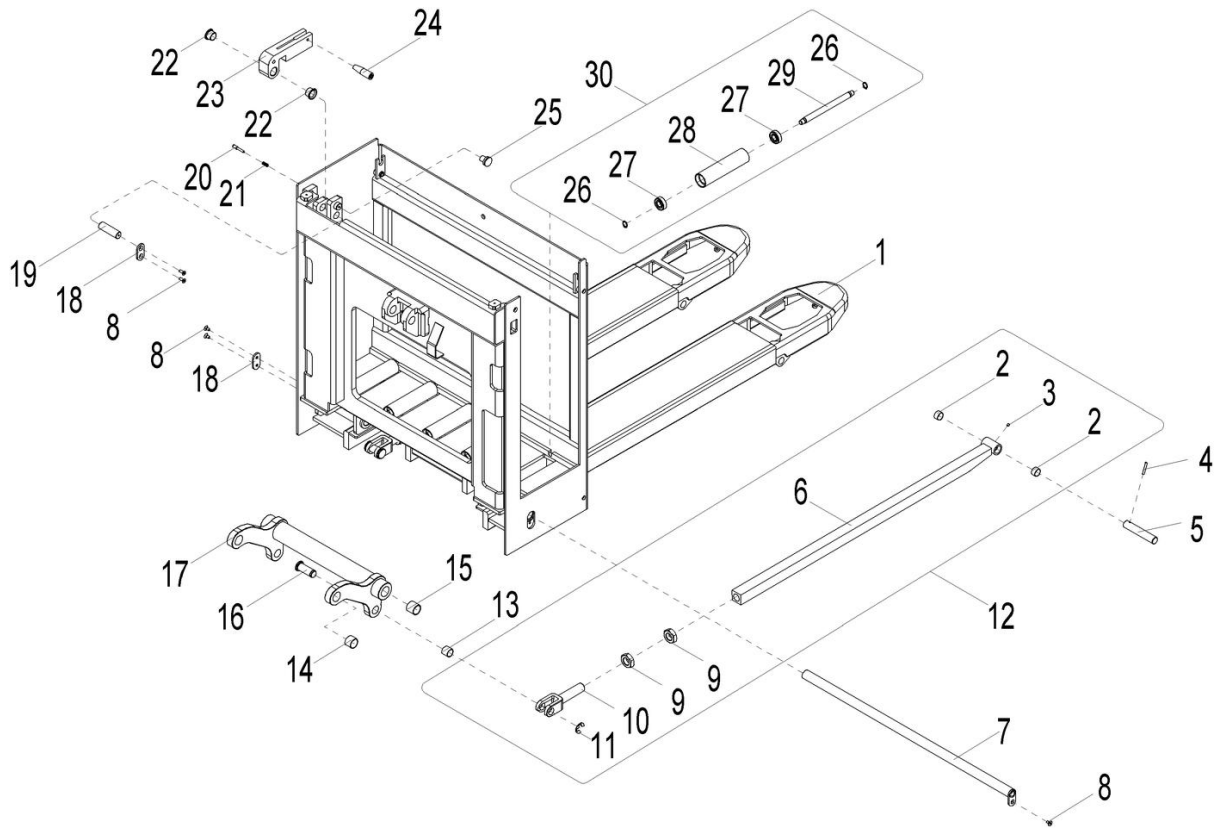

Fig. 2 PT20N Chassis (sideways)

No.	Art No.	Description	Qty.	Note
1	506738510003	Chassis welding	1	540x1150
	506738510007	Chassis welding	1	685x1220
2	940500100012	Bushing	4	20x22x12
3	911200100001	Grease nipple	2	6
4	910600500004	Dowel pin	2	5x35
5	505638520038	Frame of roller Axle	2	20x163
6	506738510005	Push rod welding	2	1150
	506938510002	Push rod welding	2	1220
7	506738510006	Plate with axle	1	25x774
8	910200400016	Screw	5	M6x12
9	910300400010	Nut	4	M24x1.5
10	505638520035	Push rod fork	2	

11	910401700005	Circlip	2	15
12	506798510002	Push rod kits	2	1150
	506798510003	Push rod kits	2	1220
13	940500100019	Bushing	2	20x23x20
14	940500100027	Bushing	2	25x28x20
15	940500100032	Bushing	2	25x29x25
16	505638520034	Short axle	2	20x51
17	505638510001	Rock arm welding	1	540
	505638510007	Rock arm welding	1	685
18	505638520031	Fixing plate	2	
19	506938520000	Axle	1	20x66
20	505638520122	Screw	1	M5x25
21	940400500001	Spring	1	6x0.7x17
22	940500200008	Bushing (With shoulder)	2	20x23x16.5
23	506738520040	Limit block(Battery)	1	
24	911000400001	Lever	1	M8x63
25	505638520123	Holder	1	
26	910401300006	Circlip	10	15
27	910700200017	Bearing	10	
28	505638520120	Tube	5	40x35x163
29	505638520119	Axle	5	15x196
30	505638510028	Tube components	5	

Fig. 3 PT25N Chassis (sideways)

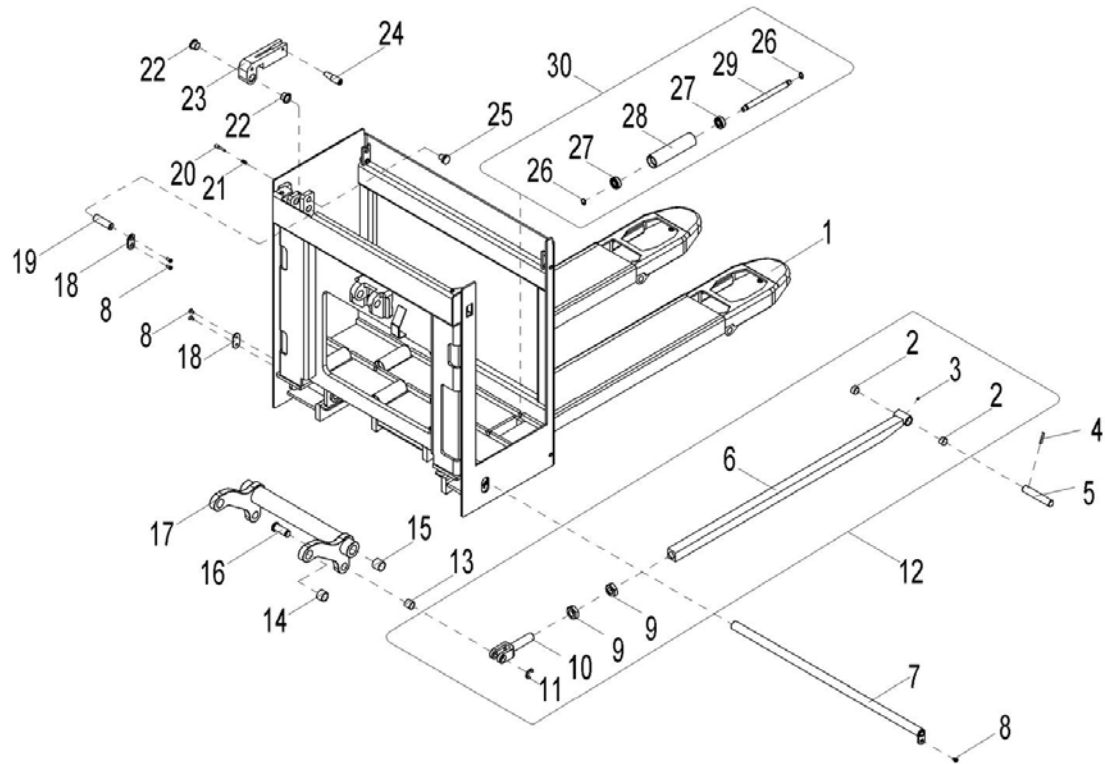

Fig. 3 PT25N Chassis (sideways)

No.	Art No.	Description	Qty.	Note
1	506938510001	Chassis welding	1	540x1150
	506938510004	Chassis welding	1	685x1220
2	940500100012	Bushing	4	20x22x12
3	911200100001	Grease nipple	2	6
4	910600500004	Dowel pin	2	5x35
5	505638520038	Frame of roller Axle	2	20x163
6	506938510002	Push rod welding	2	1150
	506938510005	Push rod welding	2	1220
7	506738510006	Plate with axle	1	25x774
8	910200400016	Screw	5	M6x12
9	910300400010	Nut	4	M24x1.5
10	505638520035	Push rod fork	2	

11	910401700005	Circlip	2	15
12	506798510003	Push rod kits	2	1150
	506798510004	Push rod kits	2	1220
13	940500100019	Bushing	2	20x23x20
14	940500100027	Bushing	2	25x28x20
15	940500100032	Bushing	2	25x29x25
16	505638520034	Short axle	2	20x51
17	505638510001	Rock arm welding	1	540
	505638510007	Rock arm welding	1	685
18	505638520031	Fixing plate	2	
19	506938520000	Axle	1	20x66
20	505638520122	Screw	1	M5x25
21	940400500001	Spring	1	6x0.7x17
22	940500200008	Bushing (With shoulder)	2	20x23x16.5
23	506738520040	Limit block (Battery)	1	
24	911000400001	Lever	1	M8x63
25	505638520123	Holder	1	
26	910401300006	Circlip	12	15
27	910700200017	Bearing	12	
28	505938520021	Tube	6	40x35x110
29	505938520020	Axle	6	15x143
30	505938510003	Tube components	6	

Fig. 4 Load roller components

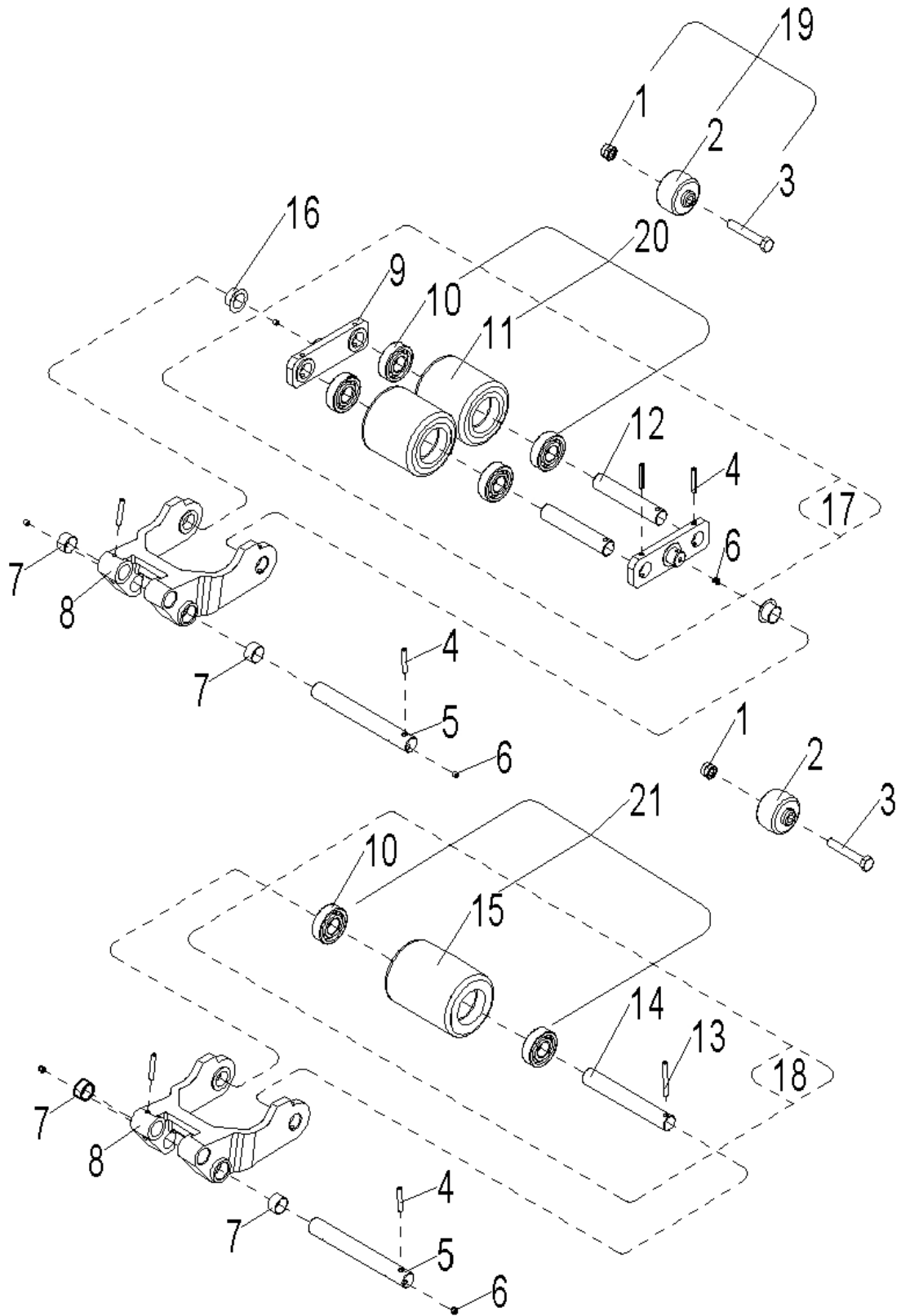

Fig. 4 Load Roller Components

No.	Art No.	Description	Qty.	Note
1	910300500005	Nut	2	M10
2	505638520039	Entry roller	2	50x10.5x40
3	910100100035	Bolt	2	M10x60
4	910600400027	Dowel pin	6/2(tandem/single)	5x35
5	505638520038	Frame of roller axle	2	20x163
6	911200100001	Grease nipple	2	6
7	940500100012	Bushing	4	20x22x12
8	505638520036	Frame of roller	2	
9	505617020001	Connecting plate	4	
10	910700200019	Bearing	8/4(tandem/single)	6204
11	940300300010	Load roller	4(tandem)	84x84
12	505617020000	Axle	4(tandem)	20x109
13	910600400030	Dowel pin	2(single)	5x50
14	505617020002	Axle	2(single)	20x138
15	940300300006	Load roller	2(single)	82x110
16	940500200003	With shoulder bushing	4(tandem)	18x20x12
17	505617001000	Load roller assembly	2	tandem
18	505617001001	Load roller assembly	2	single
19	502398510003	Entry roller kits	2	
20	505698510003	Roller set kits	4	
21	505698510004	Roller set kits	2	

Fig. 5 Driving system (Manual steering)

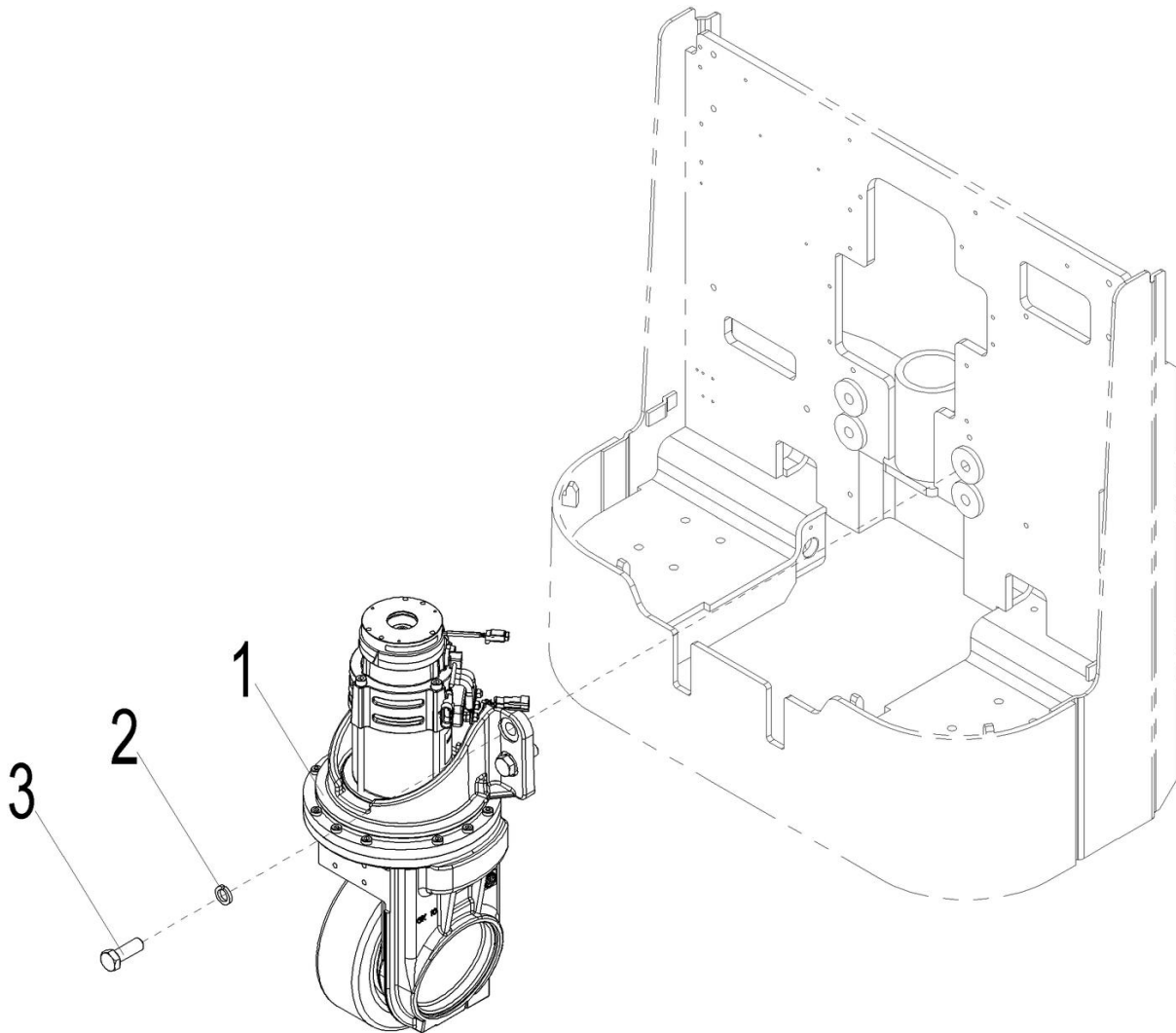

Fig. 5 Driving System (Manual steering)

No.	Art No.	Description	Qty.	Note
1	940900400005	Driving assembly	1	4699.601.247-AC-1.4kW
2	910400500010	Standard spring washer	4	16
3	910100300071	Bolt	4	M16x45

Fig. 6 Driving assembly (Manual steering)

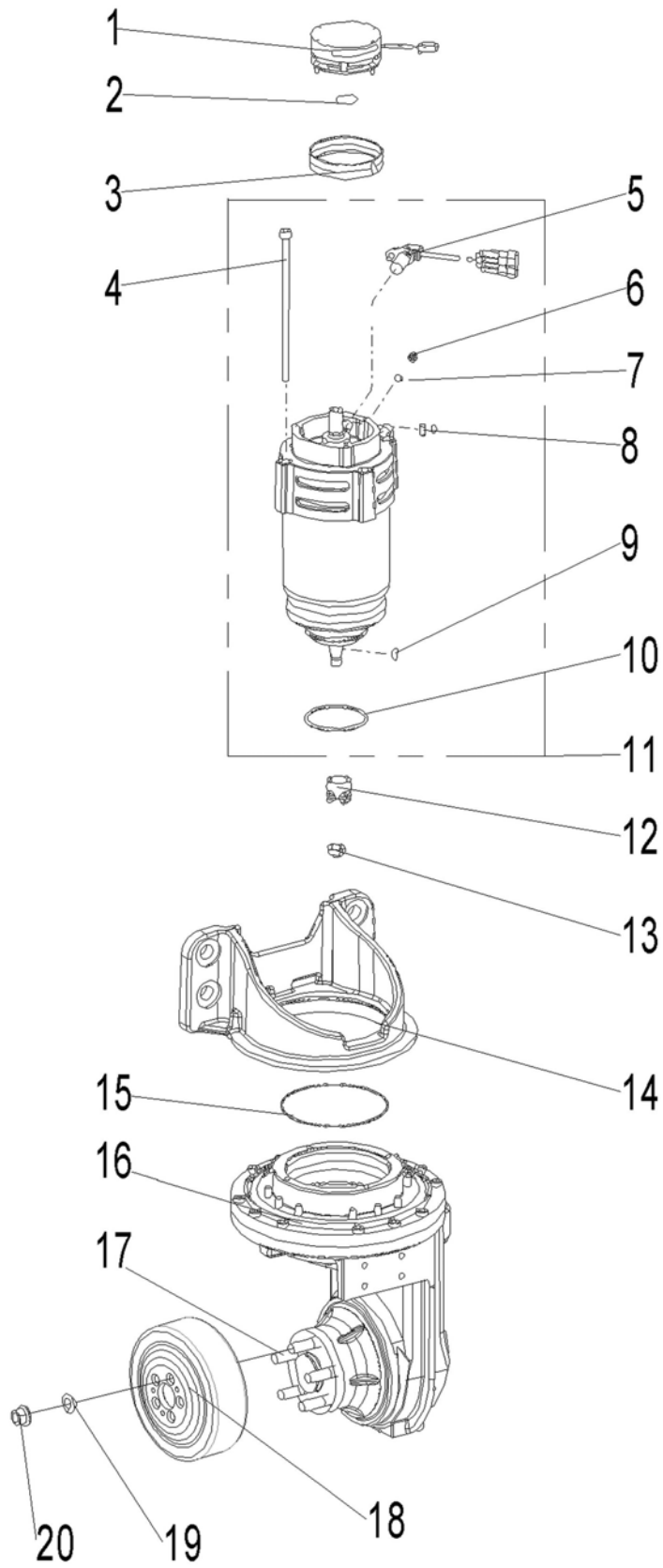

Fig. 6 Driving assembly (Manual steering)

No.	Art No.	Description	Qty.	Note
1	535998510001	Brake	1	
2	535998520000	Circlip	1	15
3	535998520001	Washer	1	
4	535998520002	Screw	4	M8x175
5	535998510002	Sensor	1	
6	535998520003	Nut	1	M6x8
7	535998520004	Security components	1	
8	535998520005	Flat key	1	5x5x14
9	535998520006	Woodruff key	1	
10	535998520007	O ring	1	
11	535998510003	motor	1	
12	535998520014	gear	1	
13	535998520008	Nut	1	
14	506798510005	Mounting base	1	
15	535998520009	O ring	1	146X3
16	535998510005	Transmission	1	
17	535998520011	stud	5	
18	940300400005	Driving wheel	1	230x70
19	535998520012	Standard spring washer	5	
20	535998520013	Nut	5	

Fig. 7 Driving system (EPS)

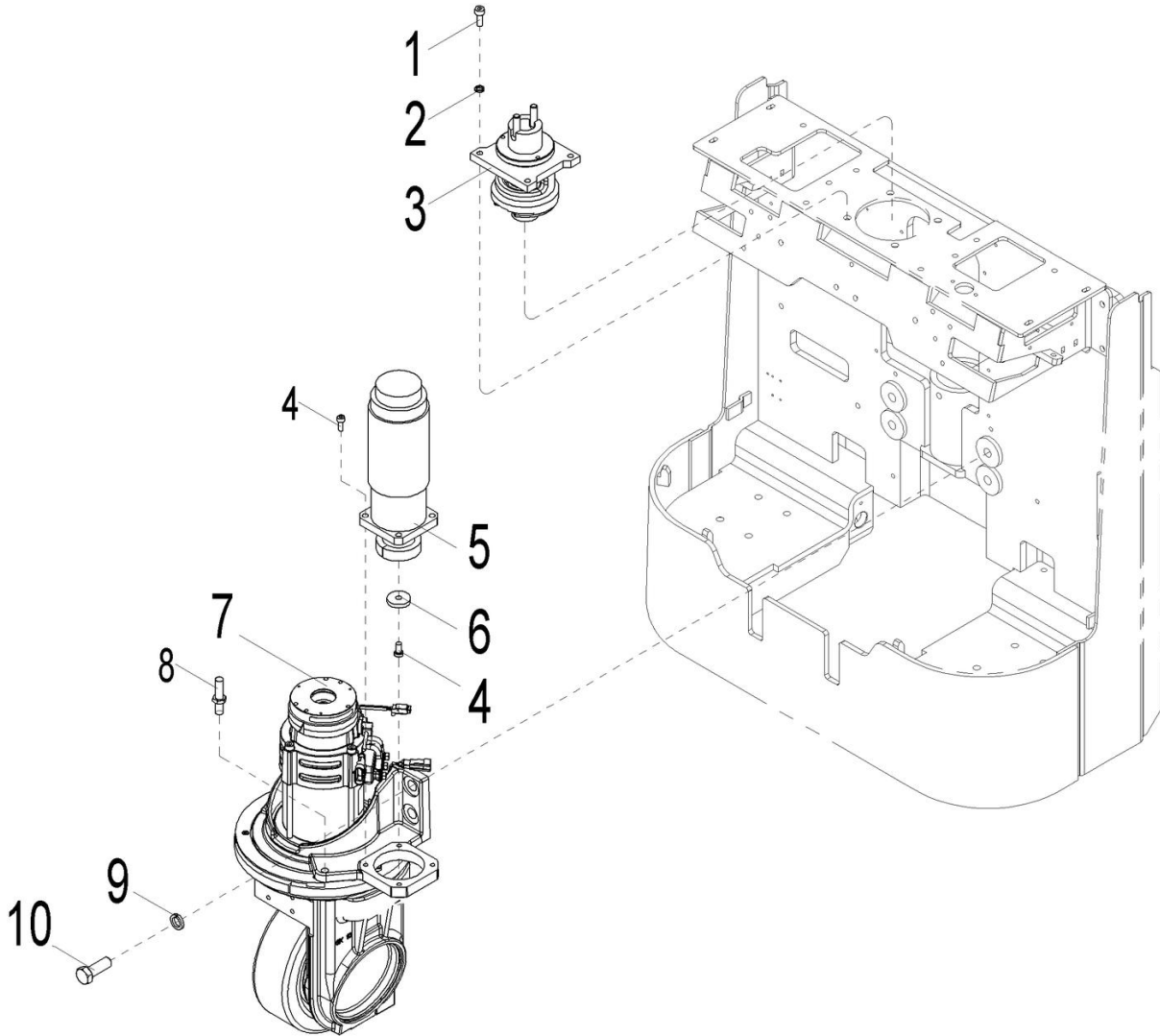

Fig. 7 Driving System (EPS)

No.	Art No.	Description	Qty.	Note
1	910200200075	Screw	4	M10x20
2	910400500007	Spring washer	4	10
3	535931501001	EPS components	1	
4	910200200057	Screw	5	M8x20
5	920900100069	motor (DC)	1	Z90DPN24400-30S-2
6	506713520001	Circlip	1	35x9x4
7	940900500009	Driving steering assembly	1	4699.601.248-AC-1.4kW
8	506733510007	Proximity switch	1	NBB4-12GM50-E0(360mm)
9	910400500010	Standard spring washer	4	16
10	910100300071	Bolt	4	M16x45

Fig. 8 Driving assembly (EPS)

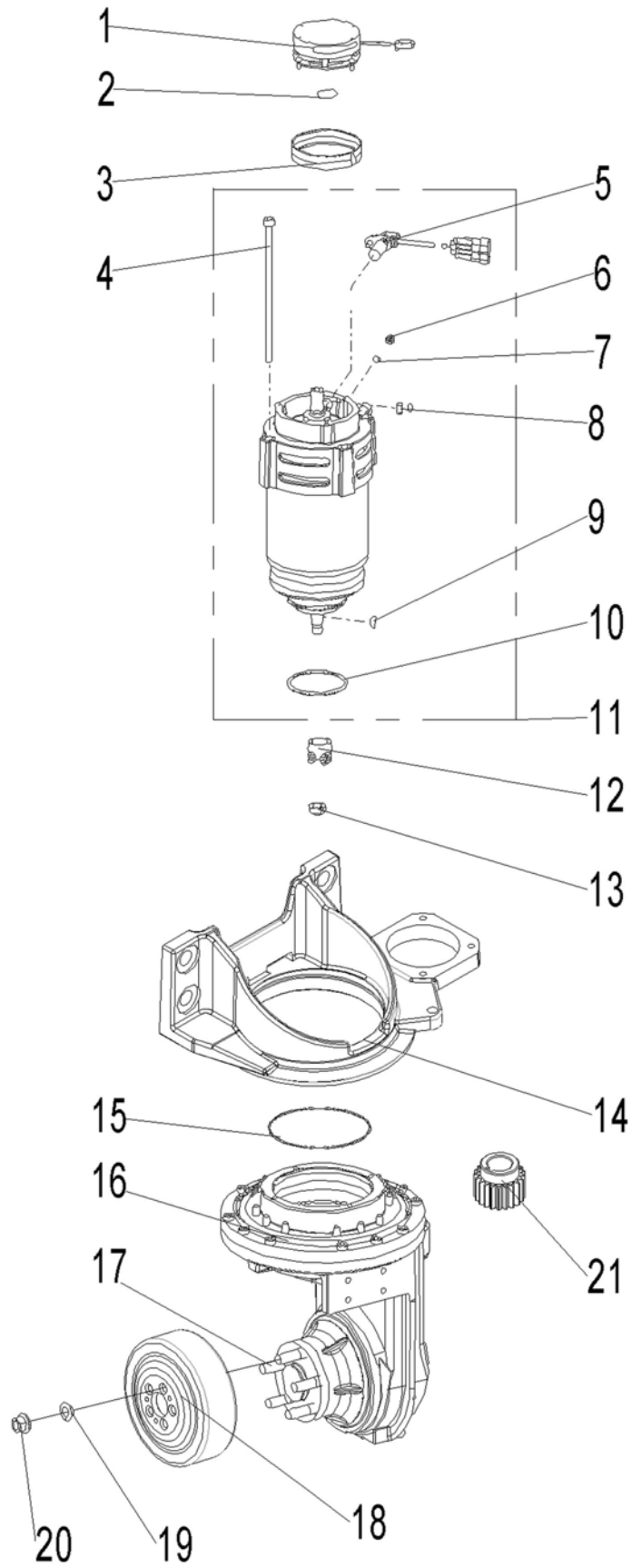

Fig. 8 Driving assembly (EPS)

No.	Art No.	Description	Qty.	Note
1	535998510001	Brake	1	
2	535998520000	Circlip	1	15
3	535998520001	Washer	1	
4	535998520002	Screw	4	M8x175
5	535998510002	Sensor	1	
6	535998520003	Nut	1	M6x8
7	535998520004	Security components	1	
8	535998520005	Flat key	1	5x5x14
9	535998520006	Woodruff key	1	
10	535998520007	O ring	1	
11	535998510003	motor	1	
12	535998520014	gear	1	
13	535998520008	Nut	1	
14	506798510006	Mounting base	1	
15	535998520009	O ring	1	146X3
16	535998510005	Transmission	1	
17	535998520011	stud	5	
18	940300400005	Driving wheel	1	230x70
19	535998520012	Standard spring washer	5	
20	535998520013	Nut	5	

Fig. 9 Steering wheel components

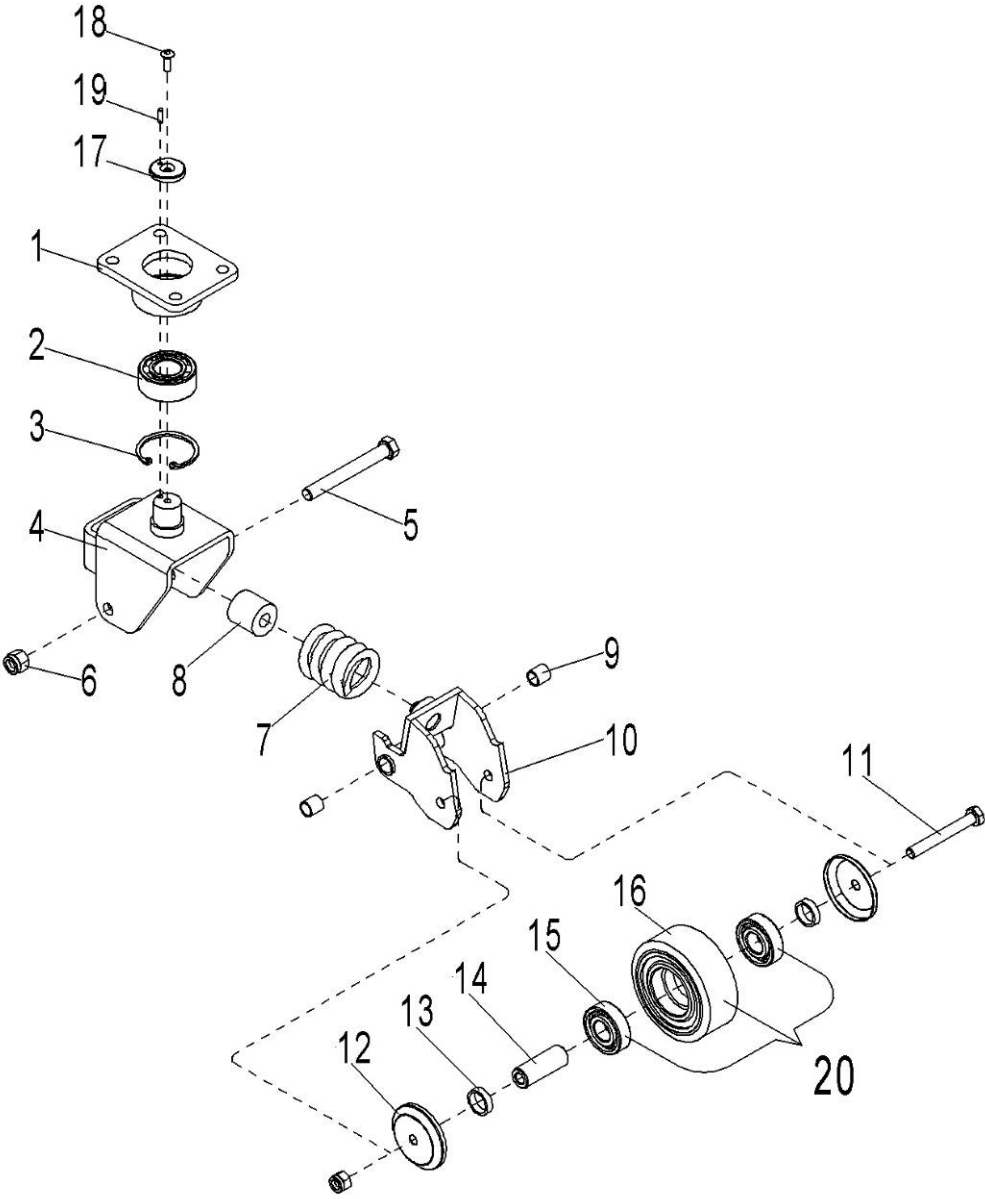

Fig. 9 Steering Wheel Components

No.	Art No.	Description	Qty.	Note
1	504416510002	Connecting plate welding	2	
2	910700500002	Bearing 3205A	2	52x25x20
3	910401400016	Circlip -A	2	52
4	505616510001	Wheel frame welding	2	
5	941100200002	Bolt	2	M12x100
6	910300500006	Nut	2	M12
7	940400500006	Spring	2	41.5x6x62
8	505616520000	PU spring	2	
9	940500100002	Bushing	4	12x15x15
10	505616510003	Rotate arm	2	
11	910100100038	Bolt	2	M10x80
12	505616520011	Dust cover	4	64x10x10
13	505616520012	Circlip	4	25x20.5x6.5
14	505616520013	Sleeve	2	20x10x53
15	910700200019	Bearing 6204	4	47x20x14
16	940300300018	Roller	2	100x40
17	505616520007	Circlip	2	32x7x5
18	941100300001	Screw	2	M6x14
19	910600100004	Dowel pin	2	4x14
20	505698510000	Roller set kits	2	

Fig. 10 PT20N Hydraulic system

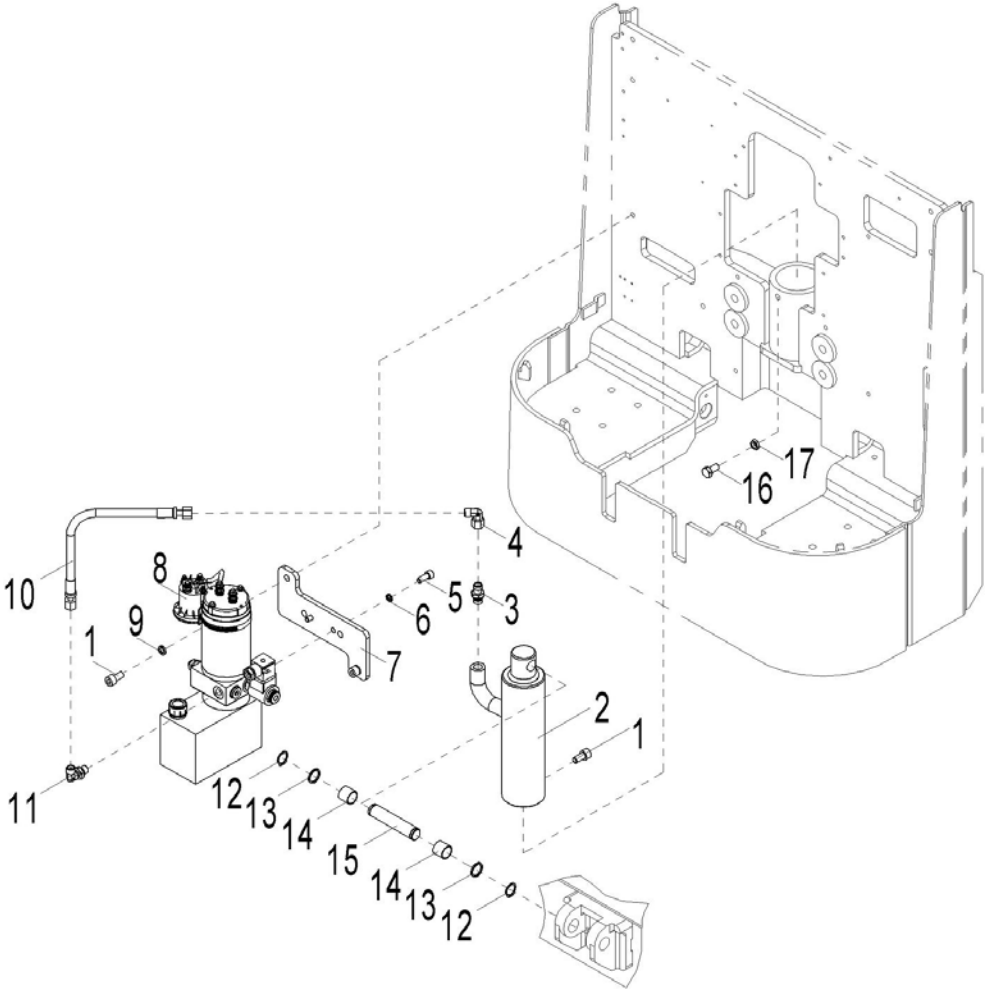

Fig. 10 PT20N Hydraulic System

No.	Art No.	Description	Qty.	Note
1	910200200075	Screw	3	M10x20
2	504424010001	Cylinder	1	54x50x120
3	950400400001	Joint (Straight)	1	8-2xM14x1.5-24°
4	950400200002	Joint	1	8-2xM14x1.5-24°
5	910200200057	Screw	2	M8x20
6	910400500006	Spring washer	2	8
7	506724020001	Mounting plate (Pump station)	1	
8	950900100036	Hydraulic power unit	1	24V0.8KW1.0cc
9	910400500007	Spring washer	2	10
10	506724010002	Hydraulic pipe assembly	1	(30°) 8-L320-1SC-24°
11	950401100002	Joint	1	
12	910401300011	Circlip	2	20
13	940600500014	Washer	2	25x20.5x1.5
14	940500100019	Bushing	2	20x23x20
15	505638520033	Short axle	1	20x102
16	910100300035	Bolt	1	M10x20
17	910300300005	Nut	1	M10

Fig. 11 PT25N Hydraulic system

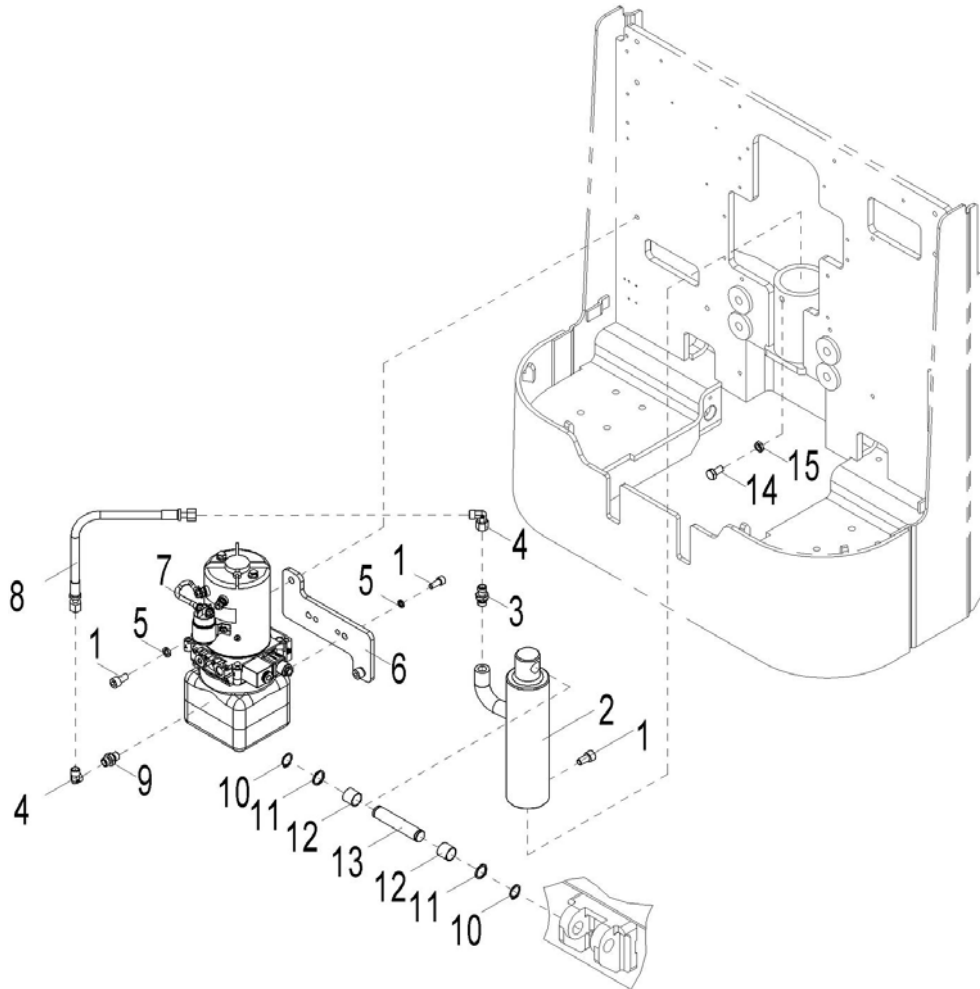

Fig. 11 PT25N Hydraulic System

No.	Art No.	Description	Qty.	Note
1	910200200075	Screw	5	M10x20
2	504424010001	Cylinder	1	54x50x120
3	950400400001	Joint (Straight)	1	8-2xM14x1.5-24°
4	950400200002	Joint	2	8-2xM14x1.5-24°
5	910400500007	Spring washer	4	10
6	506724020001	Mounting plate (Pump station)	1	
7	950900100024	Hydraulic power unit	1	24V2.2KW2.0cc
8	506924010001	Hydraulic pipe assembly	1	(30°) 8-L370-1SC-24°
9	950400300004	Joint (Straight)	1	8-G3/8-M14x1.5-24°
10	910401300011	Circlip	2	20
11	940600500014	Washer	2	25x20.5x1.5
12	940500100019	Bushing	2	20x23x20
13	505638520033	Short axle	1	20x102
14	910100300035	Bolt	1	M10x20
15	910300300005	Nut	1	M10

Fig. 12 PT20N Pump station

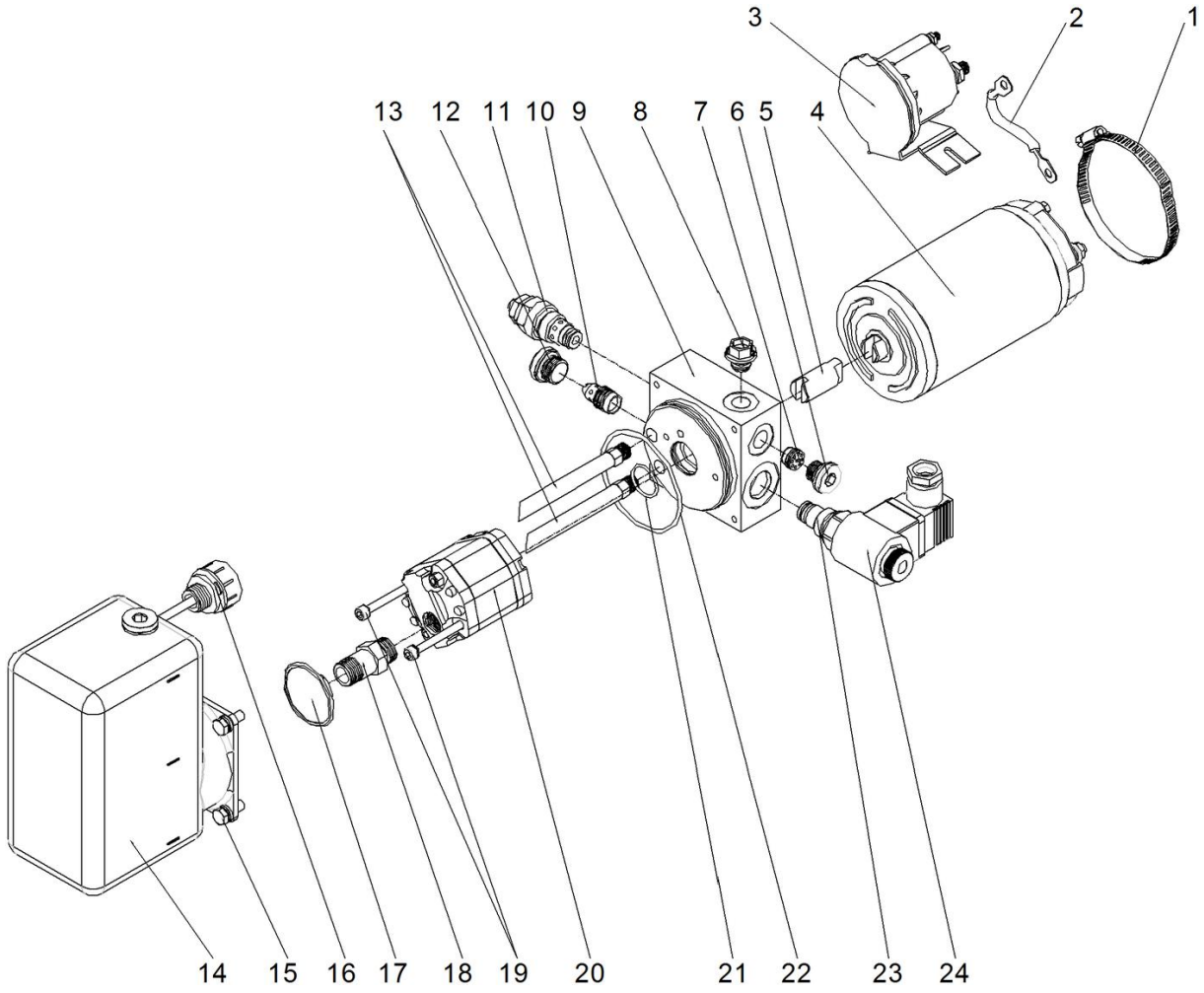

Fig. 12 PT20N Pump Station

No.	Art No.	Description	Qty.	Note
1	506798510007	Hoop	1	KG03
2	504498520026	Connecting cable	1	RSWC-04
3	504498510014	Starting switch	1	DK0324A
4	504498510007	Motor	1	MD24080AN
5	506798510008	Coupler	1	DCP-035C
6	504498520019	Plug	1	SP02
7	504498510012	Check valve	1	CV-03
8	506798510009	Plug	1	PP-02
9	5067985100010	Valve	1	B501
10	504498510016	Compensation valve	1	RPCV-02-04
11	506798510011	Overflow valve	1	RV-01
12	506798510012	Plug	1	SP-09
13	506798510013	Oil return pipe	2	RU10-100
14	506798510014	Plastic oil tank	1	1L-TP108-15B-HK1
15	910100300004	Screw	4	M5x16
16	504498520029	Cylinder cover	1	FC03
17	504498520025	Filter screen	1	FS-03A
18	506798510015	Oil suction pipe	1	FP-03V-040
19	506798510016	Screw	2	M5x70
20	506798510017	Gear pump	1	CBU-F1100
21	504498520021	O ring	1	21.2x1.8
22	506798510018	O ring	1	67.95x2.62
23	506798510019	Magnet valve	1	SCV-MRK
24	506798510020	Coil	1	YC024DC

Fig. 13 PT25N Pump station

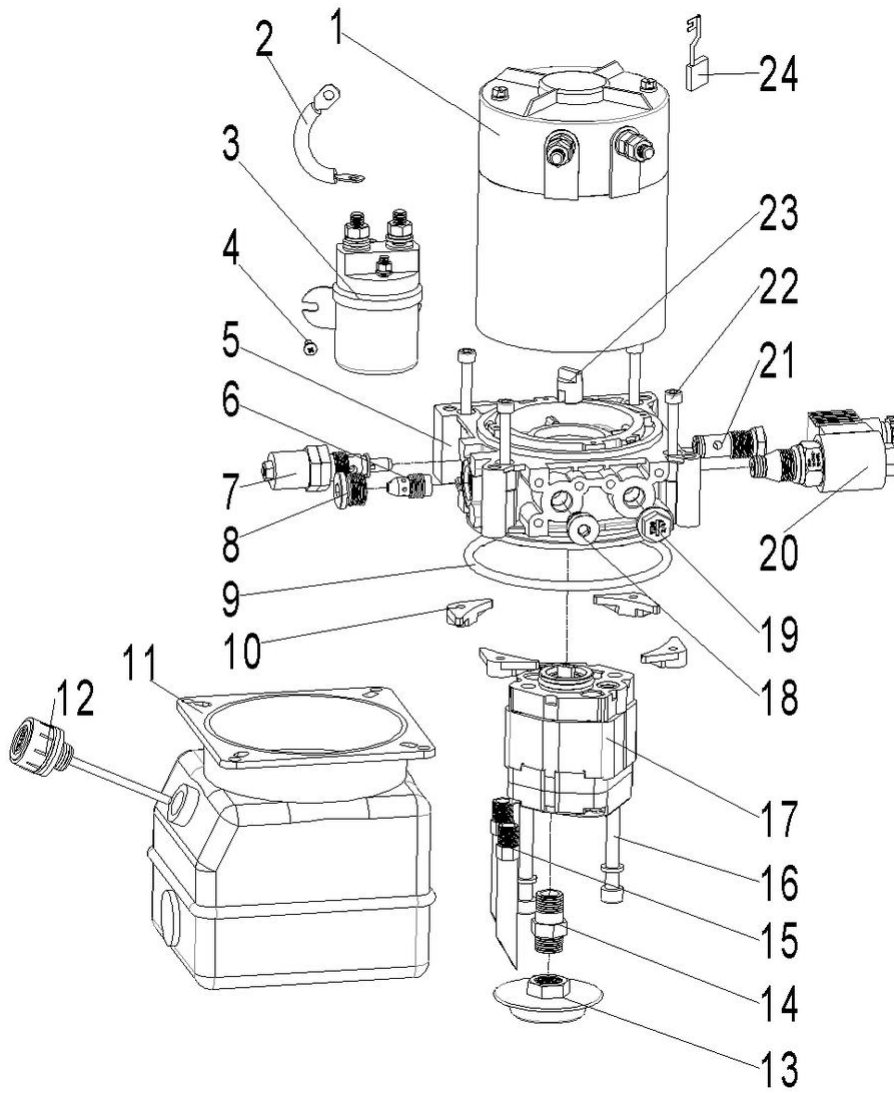

Fig. 13 PT25N Pump Station

No.	Art No.	Description	Qty.	Note
1	505798000002	Motor	1	MD24220
2	505798000003	Connecting wire	1	RSWC-01
3	505798000004	Starting switch	1	DK0324
4	505798000005	Screw	2	M5x8
5	505798000006	Valve block	1	CMF-01-03
6	505798000007	Pressure-compensated valve	1	RPCV-02-06
7	505798000008	Flood valve	1	RV-04
8	505798000009	Stopper	1	SP-06
9	505798000010	O ring	1	112x3.55
10	505798000011	Nut	4	
11	505798000012	Tank	1	1.5L-TP120A137-V
12	505798000013	Tank cap	1	FC-03N
13	505798000014	Strainer	1	FS-03B
14	505798000015	Suction pipe	1	FP-03V-035
15	505798000016	Return pipe	2	RU12-090
16	505798000017	Bolt	2	M8x80
17	505798000018	Gear pump	1	CBK-F120
18	505798000019	Stopper	1	SP-03
19	505798000020	Stopper	1	PP-03
20	505798000021	Control valve	1	SCV-024DC
21	505798000022	Check valve	1	CV-04
22	505798000023	Bolt	4	M6x45
23	505798000024	Coupling	1	DCP-048
24	505798000025	Carbon brush set	1	

Fig. 14 Cylinder components

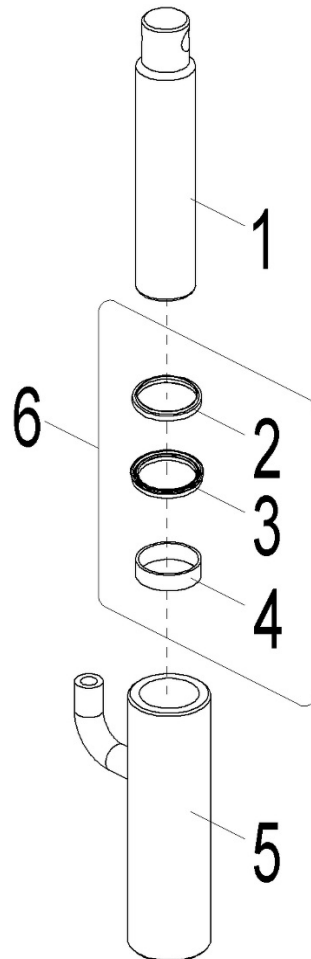

Fig. 14 Cylinder Components

No.	Art No.	Description	Qty.	Note
1	504424020001	Piston rod	1	50x258
2	504498520002	Dust ring	1	50X58X5/6.5
3	504498520001	Y Sealing ring	1	50X60X6/7
4	504498520000	Support ring	1	50x55x15
5	504424010002	Cylinder	1	
6	504498510000	Sealing kits	1	

Fig. 15 Tiller assembly

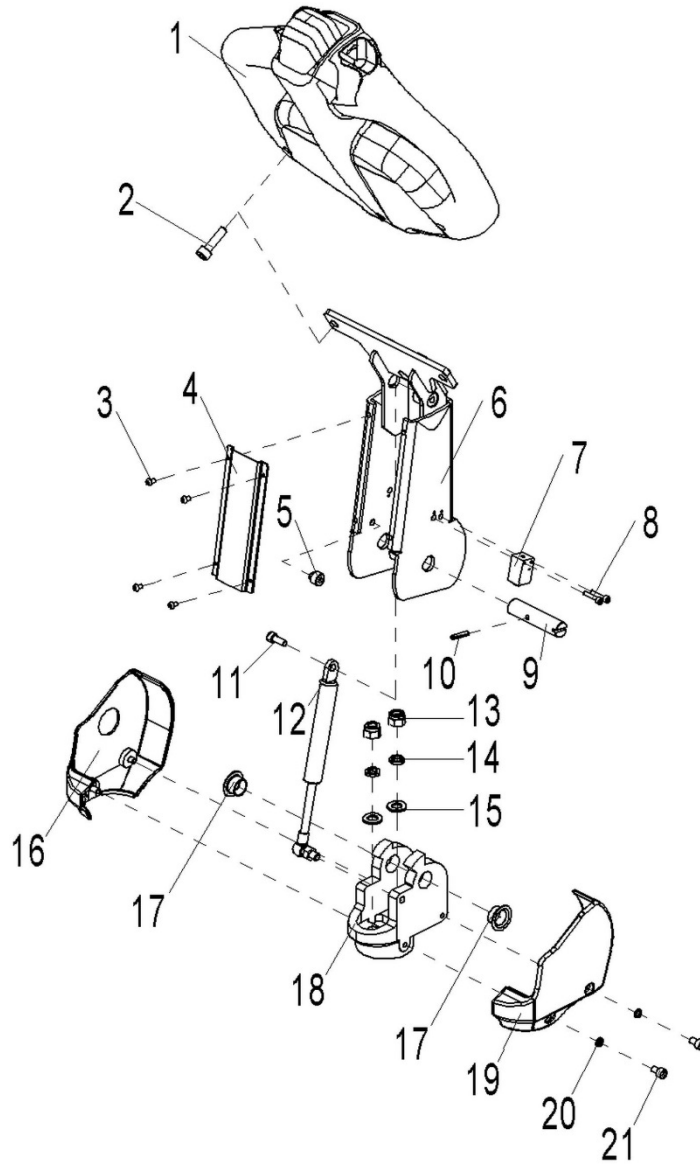

Fig. 15 Tiller Assembly

No.	Art No.	Description	Qty.	Note
1	922100100001	Canbus Tiller C	1	94300-90
2	910200200058	Screw	2	M8x25
3	910200300005	Screw	4	M4x8
4	535911020003	Cover	1	
5	505611020007	Limit screw	1	M8x5
6	535911010000	Tiller welding	1	
7	506733510002	Proximity switch	1	Fi5-Q18-OP6L(280mm)
8	910200500015	Screw	2	M3x20
9	505611020008	Axle	1	17x71
10	910600400013	Dowel pin	1	4x24
11	910200200057	Screw	1	M8x20
12	940400100001	Air spring	1	330N
13	910300500005	Nut	2	M10
14	910400500007	Spring washer	2	10
15	910400100007	Flat washer	2	10
16	535911020005	Protective cover (Tiller Left)	1	
17	940500200002	Bushing (With shoulder)	2	17x19x11
18	535911020004	Tiller base	1	
19	535911020006	Protective cover (Tiller Right)	1	
20	910400500005	Spring washer	2	6
21	910200300016	Screw	2	M6x10

Fig. 16 Tiller components

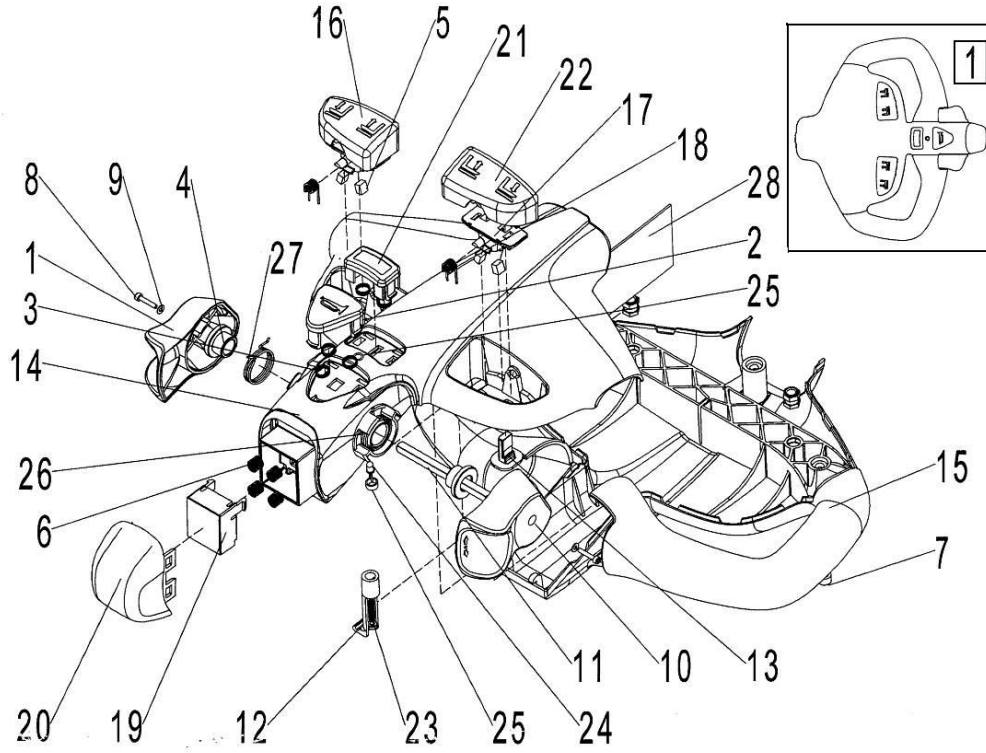

Fig. 16 Tiller Components

No.	Art No.	Description	Qty.	Note
1	505698520001	Left driving knob	1	
2	505698520002	Horn	1	
3	505698520003	Spring	5	
4	505698520004	Sleeve	2	
5	505698520005	Magnet	4	
6	505698520006	Spring of emergent reverse button	4	
7	505698520007	Screw	3	M6x10
8	505698520008	Screw	2	M3x16
9	505698520009	Flat pad	2	3
10	505698520010	Right driving knob	1	
11	505698520011	Driving knob Axle	1	
12	505698520012	PCB clip	1	
13	505698520013	Sensor	2	
14	505698520014	Tiller	1	
15	505698520015	Tiller	1	
16	505698520016	Left button	1	
17	505698520017	Magnet fixing base	2	
18	505698520018	Torsional spring	2	
19	505698520019	Emergent reverse button base	1	
20	505698520020	Cover	1	
21	505698520021	Cover	1	
22	505698520022	Right button	1	
23	505698520023	Screw	1	ST4.2x25
24	505698520024	LED bi-color light	1	
25	505698520025	LED bi-color light base	1	
26	505698520026	Right driving knob torsional spring	1	
27	505698520027	Left driving knob torsional spring	1	
28	505698520028	PCB	1	

Fig. 17 Outer appearance

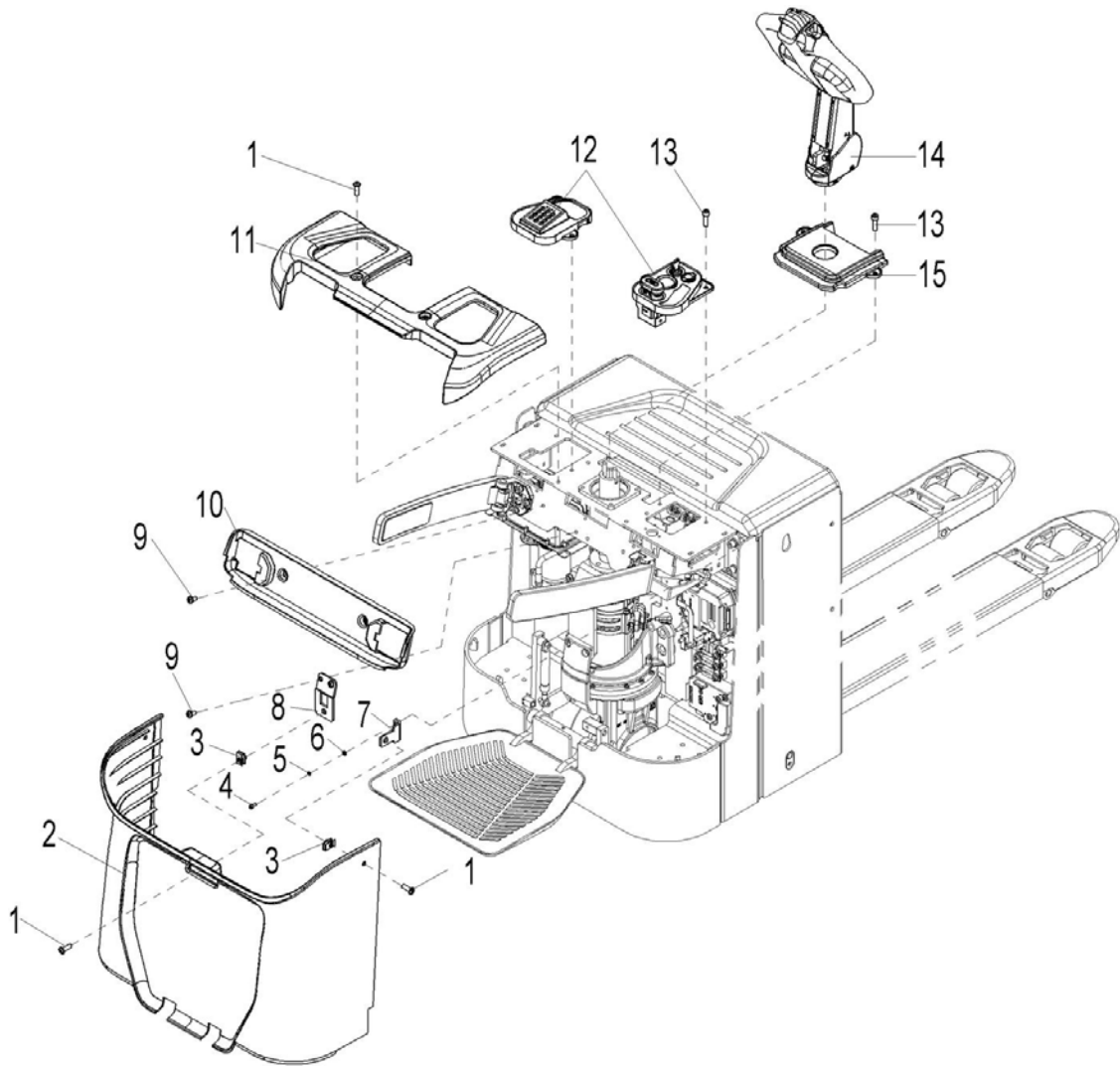

Fig. 17 Outer Appearance

No.	Art No.	Description	Qty.	Note
1	941100100004	Screw	5	M10x30
2	535921520039	Protective cover (Electrical box)	1	
3	940400400003	Nut	3	M10
4	910200200035	Screw	4	M6x16
5	910400500005	Spring washer	4	6
6	910400100005	Flat washer	4	6
7	535921520031	Mounting plate (Electrical cover)	1	
8	535921520032	Mounting plate (Electrical cover)	1	
9	941100100005	Screw	4	M10x15
10	535921520041	Protective cover (Protective arm)	1	
11	535921520040	Protective cover (Top)	1	
12	535910001000	Panel components (Built-in charger, with pin-code panel)	1	
	535910001001	Panel components (Built-in charger, without pin-code panel)	1	
	535910001002	Panel components (External charger, with pin-code panel)	1	
	535910001003	Panel components (External charger, without pin-code panel)	1	
13	910200200035	Screw	6	M6x16
14	535911001000	Tiller assembly	1	REMA Canbus
15	535921520042	Protective cover (Middle)	1	

Fig. 18 Battery cover components

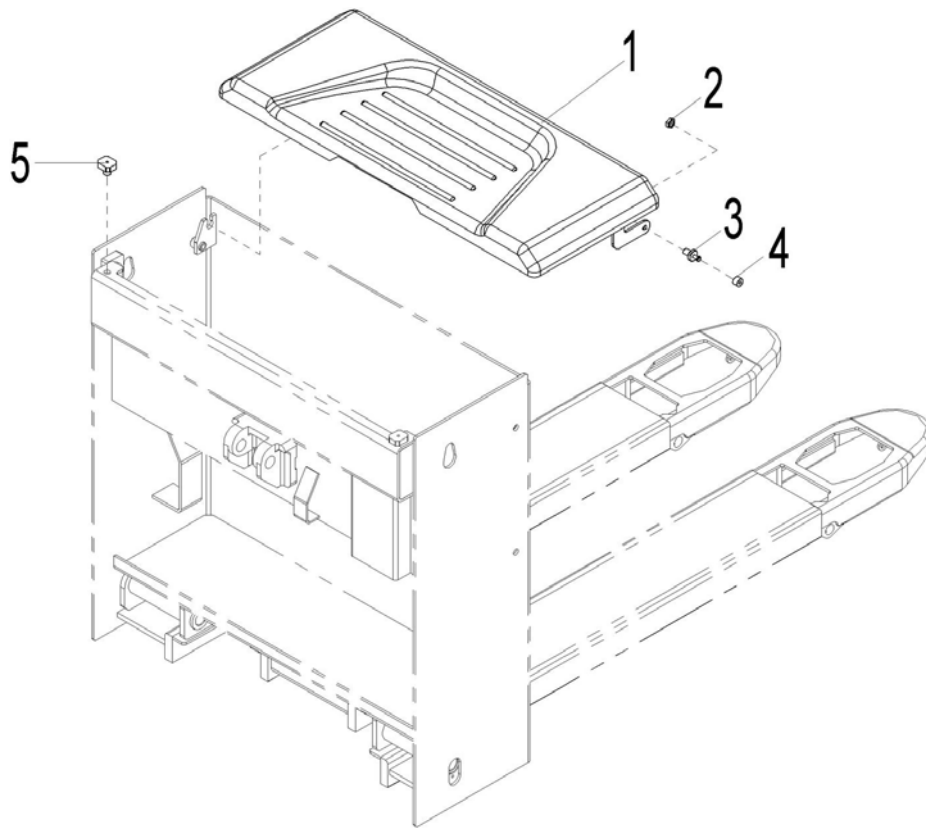

Fig. 18 Battery Cover Components

No.	Art No.	Description	Qty.	Note
1	506721010000	Battery cover welding	1	PT20N
	506721010001	Battery cover welding	1	PT20N sideways
	506921010001	Battery cover welding	1	PT25N sideways
2	910300300005	Nut	2	M10
3	505621020005	Hinge axle	2	8x19
4	505621020004	Damping pad	2	15x6x10
5	505938520016	Damping pad	2	

Fig. 19 Load backrest assembly

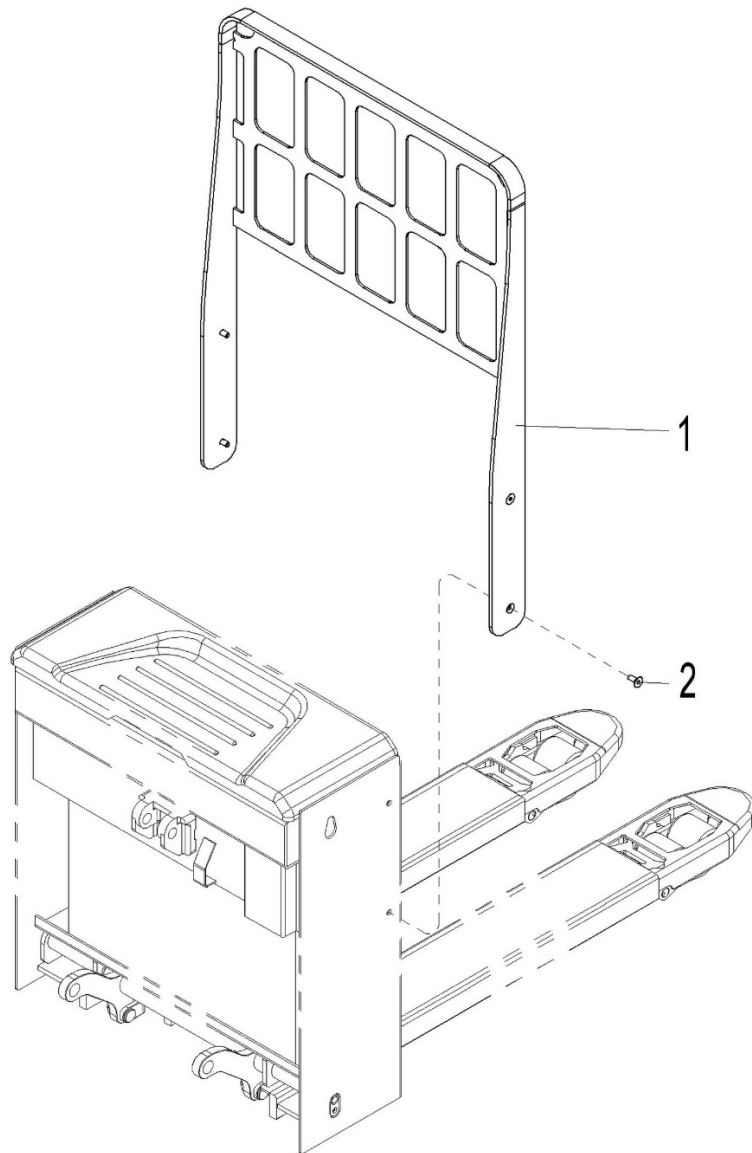

Fig. 19 Load Backrest Assembly

No.	Art No.	Description	Qty.	Note
1	506740510001	Load backrest welding	1	
2	910200400036	Screw	4	M10x25

Fig. 20 Load backrest assembly (sideways)

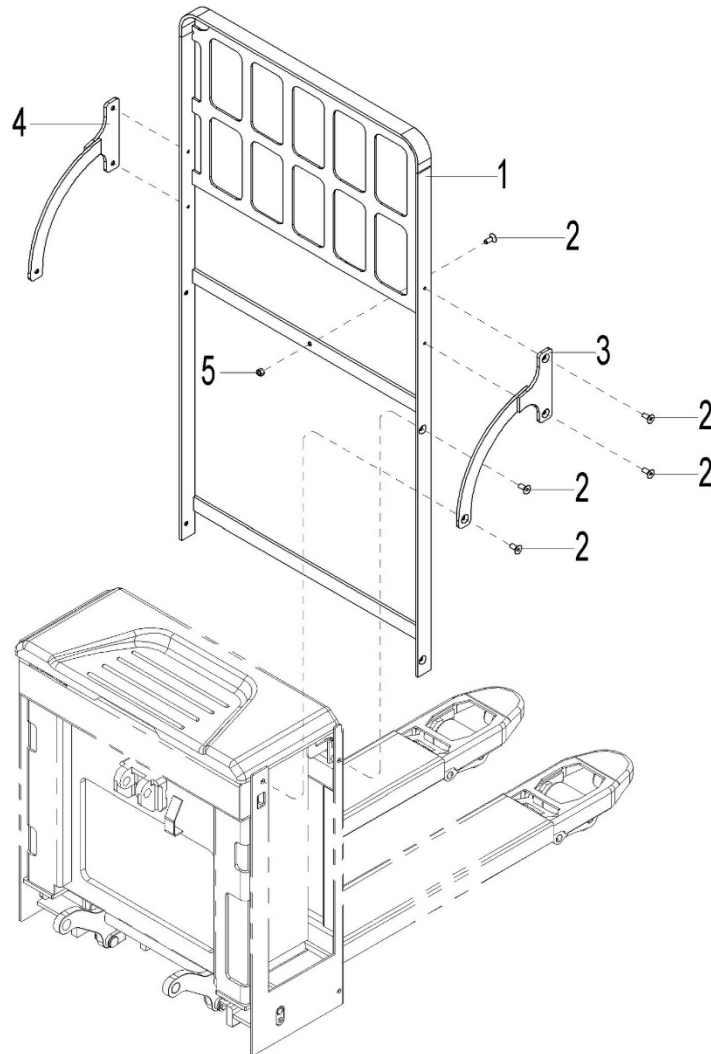

Fig. 20 Load backrest assembly (sideways)

No.	Art No.	Description	Qty.	Note
1	506740510000	Load backrest welding	1	
2	910200400036	Screw	11	M10x25
3	506740510003	Support plate (right)	1	
4	506740510002	Support plate (left)	1	
5	910300100007	Nut	1	M10

Fig. 21 Platform assembly

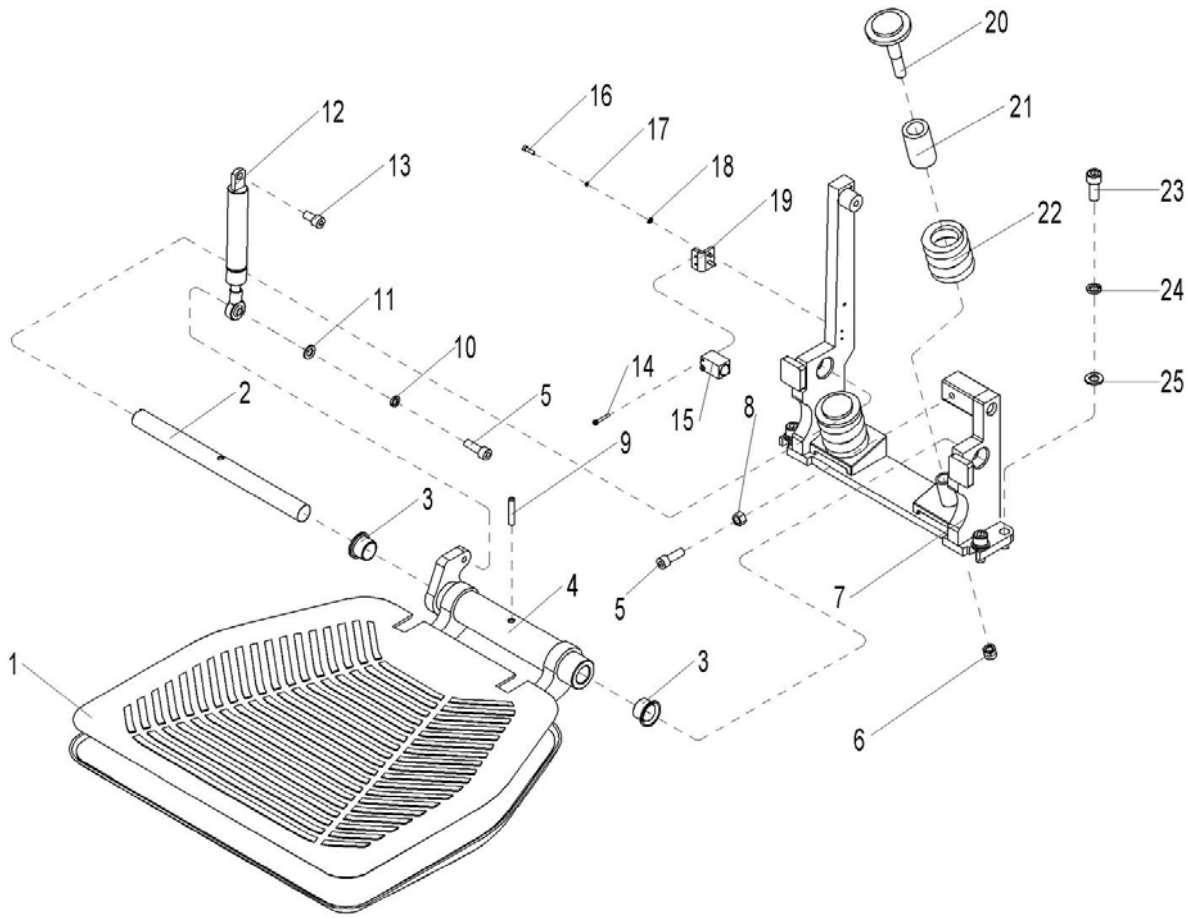

Fig. 21 Platform assembly

No.	Art No.	Description	Qty.	Note
1	535918020019	Platform pad	1	
2	535918020014	Axle	1	20x257
3	940500200008	Bushing (With shoulder)	2	20x23x16.5
4	535918010001	Platform welding	1	
5	910200200058	Screw	2	M8x25
6	910300500006	Nut	2	M12
7	535918010000	Mounting base welding	1	
8	910300100007	Nut	1	M10
9	910600400040	Dowel pin	1	6x35
10	910400500006	Spring washer	1	8
11	910400100006	Flat washer	1	8
12	940400100038	Air spring	1	800N
13	910200200057	Screw	1	M8x20
14	910200500015	Screw	2	M3x20
15	535933510002	Proximity switch	1	Fi5-Q18-OP6L(600mm)
16	910200200003	Screw	2	M3x12
17	910400500002	Spring washer	2	3
18	910400100002	Flat washer	2	3
19	535918020015	Mounting plate (Proximity switch)	1	
20	535918020017	Bolt	2	M12x72
21	535918020018	PU bushing	2	29x19x48
22	535918020016	Spring	2	40x9.5x48
23	910200200076	Screw	4	M10x25
24	910400500007	Spring washer	4	10
25	910400100007	Flat washer	4	10

Fig. 22 Protective arm assembly

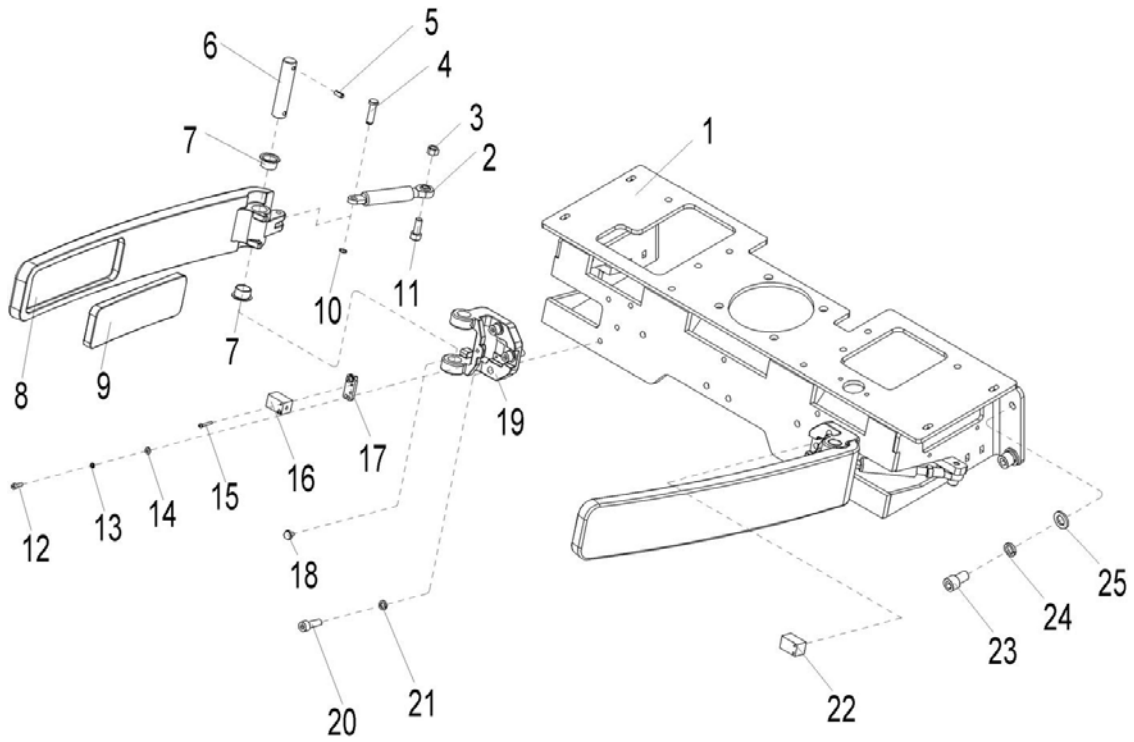

Fig. 22 Protective Arm Assembly

No.	Art No.	Description	Qty.	Note
1	535917510000	Protective arm mounting base	1	
2	940400100037	Air spring	2	250N
3	910300100006	Nut	2	M8
4	535917520010	Axle	2	8x29
5	910600400025	Dowel pin	2	5x30
6	535917520007	Axle	2	18x80
7	940500200003	Bushing (With shoulder)	4	18x20x12
8	535917520008	Protective arm	2	
9	535917520009	Protective pad	2	
10	910401300001	Circlip	2	8
11	910200200060	Screw	2	M8x35
12	910200200014	Screw	4	M4x12
13	910400500003	Spring washer	4	4
14	910400100003	Flat washer	4	4
15	910200500015	Screw	4	M3x20
16	535933510001	Proximity switch	1	Fi5-Q18-OP6L(350mm)
17	535917520011	Mounting plate (Protective arm	2	
18	535917520012	Protective pad	2	
19	535917520006	Mounting base (Protective arm)	2	
20	910200200058	Screw	6	M8x25
21	910400500006	Spring washer	6	8
22	535933510000	Proximity switch	1	Fi5-Q18-OP6L(420mm)
23	910200200096	Screw	4	M12x20
24	910400500008	Spring washer	4	12
25	910400100008	Flat washer	4	12

Fig. 23 EPS components

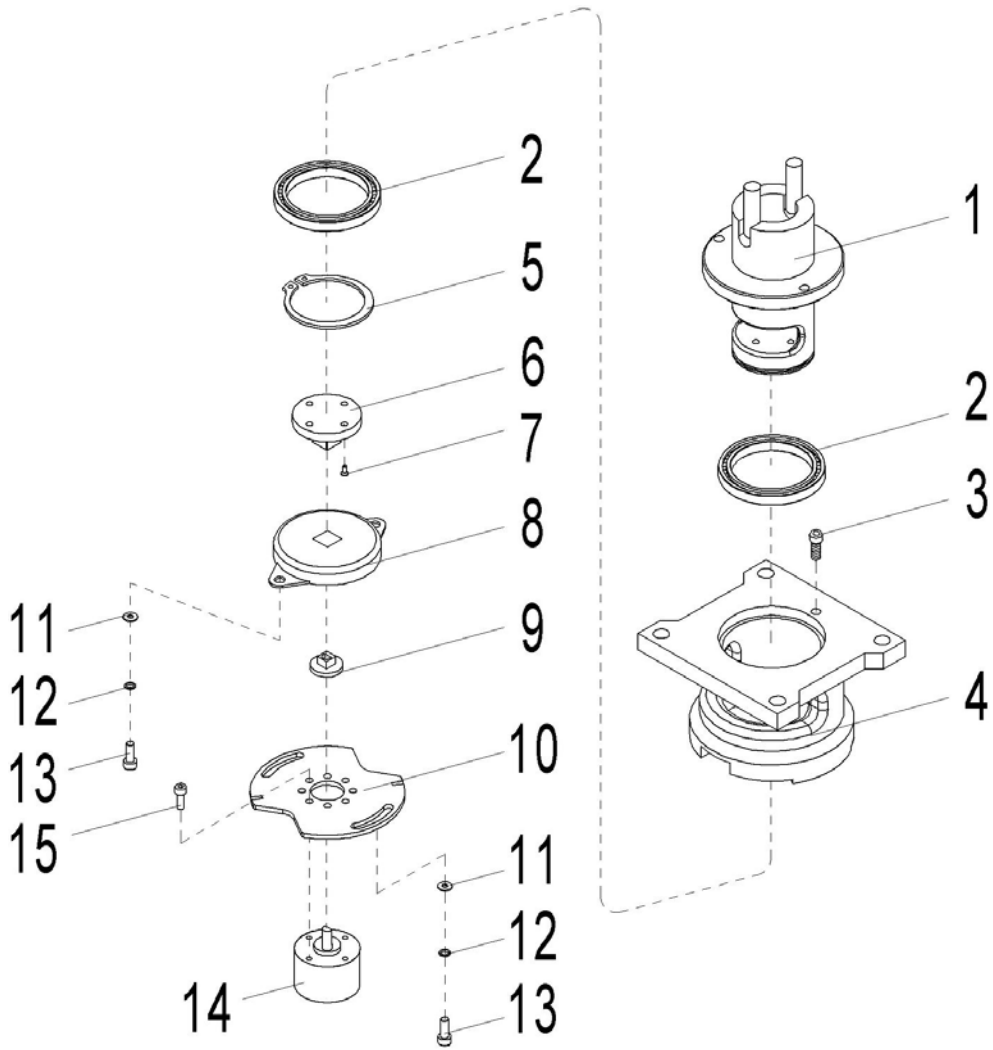

Fig. 23 EPS Components

No.	Art No.	Description	Qty.	Note
1	535931510001	Axle base welding	1	
2	910700200041	Bearing 61810	2	65x50x7
3	910200200032	Screw	3	M6x10
4	505631520002	Fixing base	1	
5	910401300024	Circlip	1	50
6	505631520005	Connecting block	1	
7	910200200013	Screw	4	M4x10
8	940801200001	Damper	1	
9	505931520002	Connecting block	1	
10	535931520002	Mounting plate (Potentiometer)	1	
11	910400100004	Flat washer	4	5
12	910400500004	Spring washer	4	5
13	910200200021	Screw	4	M5x10
14	506733510000	Potentiometer	1	013400-89001AAB
15	910200200014	Screw	4	M4x12

Fig. 24 Manual steering components

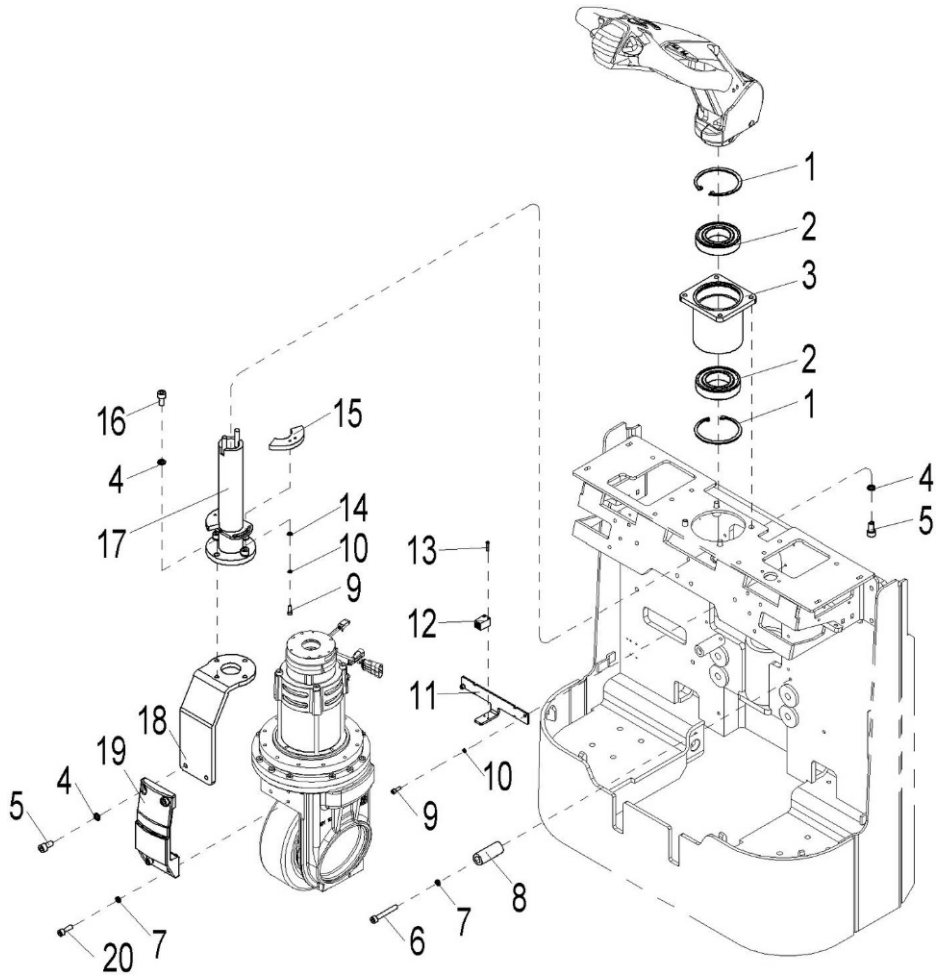

Fig. 24 Manual Steering Components

No.	Art No.	Description	Qty.	Note
1	910401400024	Circlip	2	90
2	910700200025	Bearing 6210	2	90x50x20
3	506731210002	Fixing base welding	1	
4	910400500007	Spring washer	12	10
5	910200200075	Screw	8	M10x20
6	910200200065	Screw	2	M8x60
7	910400500006	Spring washer	6	8
8	506731220004	Limit base	2	
9	910200200023	Screw	6	M5x16
10	910400500004	Spring washer	6	5
11	506731220003	Mounting plate (Proximity switch)	1	
12	506733510001	Proximity switch	1	Fi5-Q18-OP6L(200mm)
13	910200500015	Screw	2	M3x20
14	910400100004	Flat washer	4	5
15	506731220002	Limit plate	2	
16	910200200076	Screw	4	M10x25
17	506731210001	Tiller arm welding	1	
18	506731220001	Connecting plate	1	
19	535931220001	Connecting base	1	
20	910200200058	Screw	4	M8x25

Fig. 25 Electrical box components

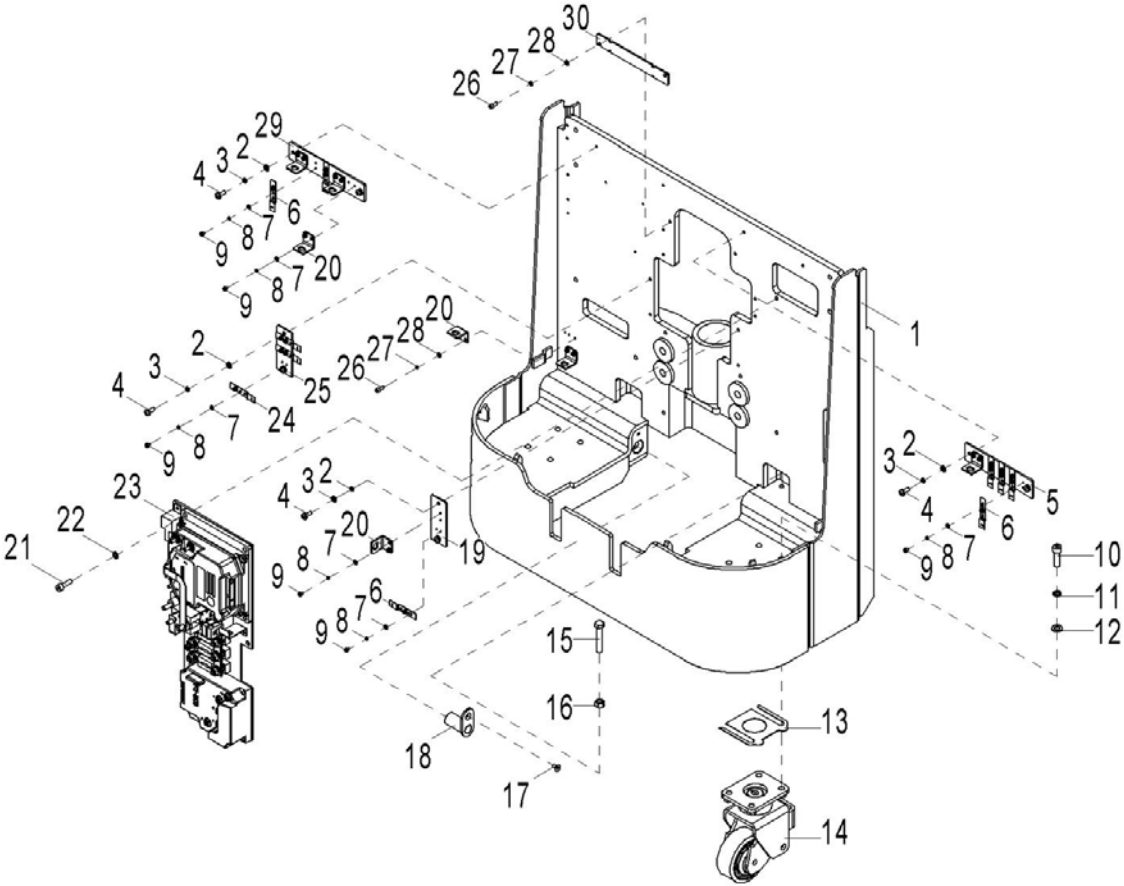

Fig. 25 Electrical Box Components

No.	Art No.	Description	Qty.	Note
1	506721510000	Chassis welding	1	
2	910400100005	Flat washer	8	6
3	910400500005	Spring washer	8	6
4	910200500052	Screw	8	M6x16
5	506721520016	Mounting plate 2	1	
6	921300300005	Plug 2 pins base	7	
7	910400100003	Flat washer	30	4
8	910400500003	Spring washer	30	4
9	910200500020	Screw	30	M4x6
10	910200200078	Screw	8	M10x35
11	910400500007	Spring washer	8	10
12	910400100007	Flat washer	8	10
13	505616520014	Adjusting pad	Several	
14	504416510001	Roller assembly	2	100x40(PU)
15	910100300043	Bolt	2	M10x60
16	910300100007	Nut	2	M10
17	910200400016	Screw	2	M6x12
18	505921510002	Plate with axle	2	25x47
19	506721520018	Mounting plate 4	1	
20	921300300003	Plug fixing frame 4 pins	7	
21	910200200058	Screw	3	M8x25
22	910400500006	Spring washer	3	8
23	506733010018	Electrical control components (AC-0)	1	Only for manual steering
	506733010019	Electrical control components (AC-0+EPSDC0)	1	Only for EPS
	506933010006	Electrical control components (AC-0)	1	Only for PT25N manual
	506933010007	Electrical control components (AC-0+EPSDC0)	1	Only for PT25N EPS
24	921300300010	Plug base	3	
25	506721520015	Mounting plate 1	1	
26	910200200022	Screw	6	M5x12
27	910400500004	Spring washer	6	5
28	910400100004	Flat washer	6	5
29	506721520017	Mounting plate 3	1	
30	506721520019	Fixing plate (Cable)	1	Only for EPS

Fig. 26 Electrical parts

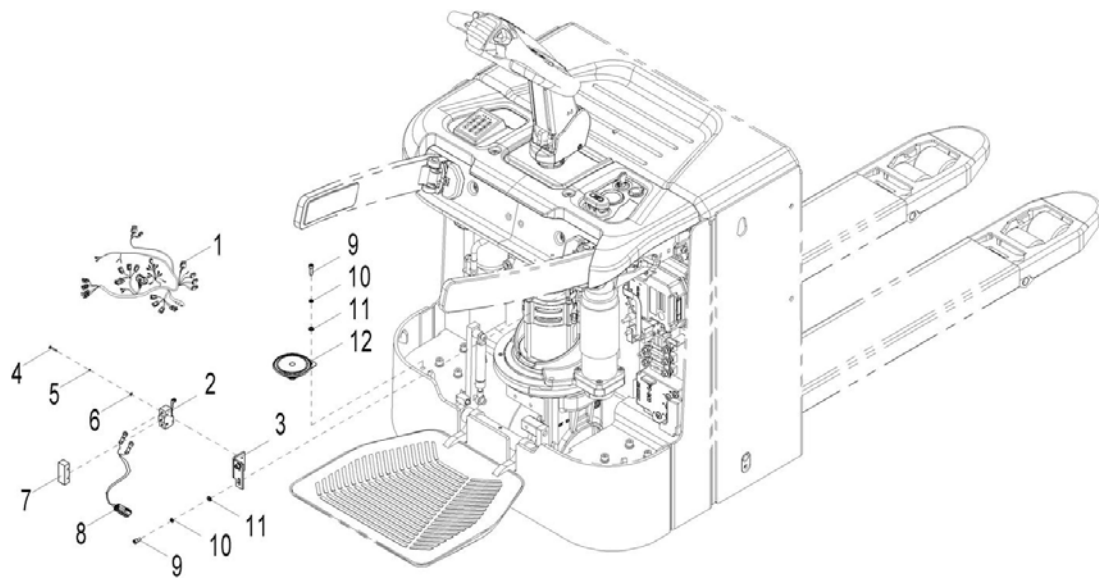

Fig. 26 Electrical Parts

No	Art No.	Description	Qty	Note
1	50673301000 0	Main control wiring harness (AC-0)	1	Only for manual steering
	50673301000 1	Main control wiring harness (AC-0+EPSC0)	1	Only for EPS
2	92020030000 3	Micro switch	1	RZ-15GW2S-B3
3	50672152001 4	Mounting plate (Limit switch)	1	
4	91020050002 8	Screw	2	M4x30
5	91040050000 3	Spring washer	2	4
6	91040010000 3	Flat washer	2	4
7	92020030000 8	Micro switch protective cover	1	
8	50673301000 4	Limit control wiring harness (300mm)	1	
9	91020020003 5	Screw	3	M6x16
10	91040050000 5	Spring washer	3	6
11	91040010000 5	Flat washer	3	6
12	92050010000 1	Horn	1	125-DC24V

Fig. 27 PT20N Battery components (External charger)

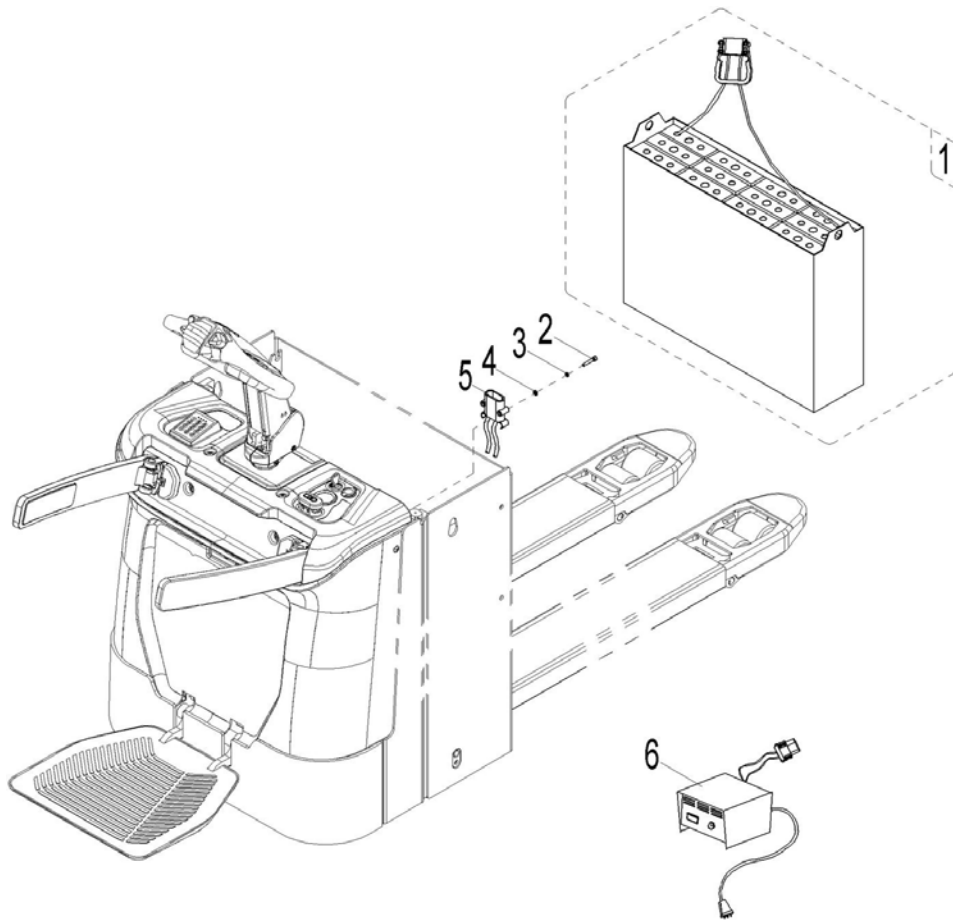

Fig. 27 PT20N Battery Components (External charger)

No.	Art No.	Description	Qty.	Note
1	505637010000	Traction battery	1	Bolt type
	505637010001	Traction battery	1	Weld type
2	910200200039	Screw	2	M6x30
3	910400500005	Spring washer	2	6
4	910400100005	Flat washer	2	6
5	920400100001	Plug REMA95199-00	1	80A
5	921000200283	Charger 24V/30A	1	Asia Chinese
	921000200289	Charger 24V/30A	1	Asia English
	921000200293	Charger 24V/30A	1	EU
	921000200301	Charger 24V/30A	1	AUS
	921000200297	Charger 24V/30A	1	ENG
	921000200305	Charger 24V/30A	1	US
	921000200001	Charger 24V/30A	1	Asia Chinese
	921000200002	Charger 24V/30A	1	Asia English
	921000200003	Charger 24V/30A	1	EU
	921000200004	Charger 24V/30A	1	AUS
	921000200005	Charger 24V/30A	1	ENG
	921000200006	Charger 24V/30A	1	US

Fig. 28 PT20N Battery components (Built-in charger)

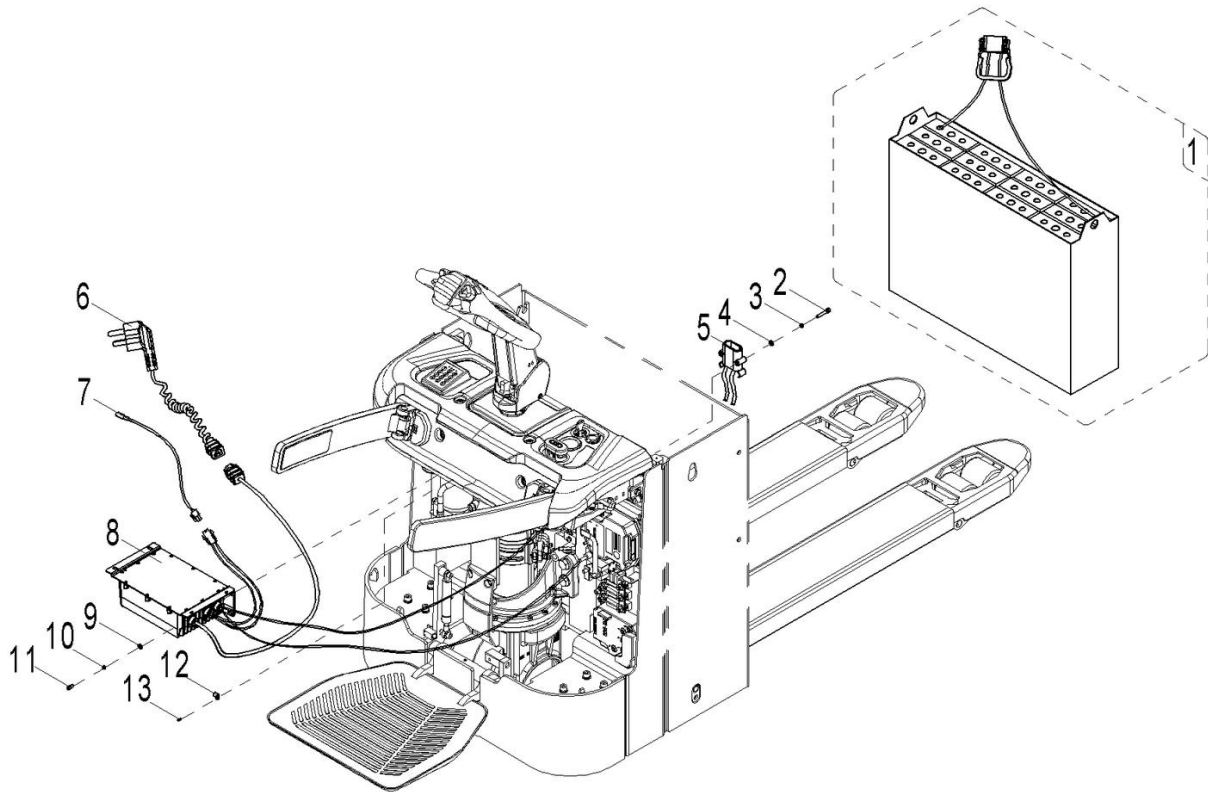

Fig. 28 PT20N Battery Components (Built-in charger)

No.	Art No.	Description	Qty.	Note
1	505637010000	Traction battery	1	Bolt type
	505637010001	Traction battery	1	Weld type
2	910200200039	Screw	2	M6x30
3	910400500005	Spring washer	2	6
4	910400100005	Flat washer	2	6
5	920400100001	Plug REMA95199-00	1	80A
6	921500200008	Spring cord	1	
7	922000100019	Light -280	1	Indicator
8	506736501012	Charger 24V/30A	1	Asia
	506736501014	Charger 24V/30A	1	EU
	506736501015	Charger 24V/30A	1	AUS
	506736501016	Charger 24V/30A	1	ENG
	506736501017	Charger 24V/30A	1	US
9	910400100005	Flat washer	4	6
10	910400500005	Spring washer	4	6
11	910200200036	Screw	4	M6x20
12	921300200001	Cable fixing parts UC-1	2	
13	910200500034	Screw	2	M4x8

Fig. 29 PT25N Battery components

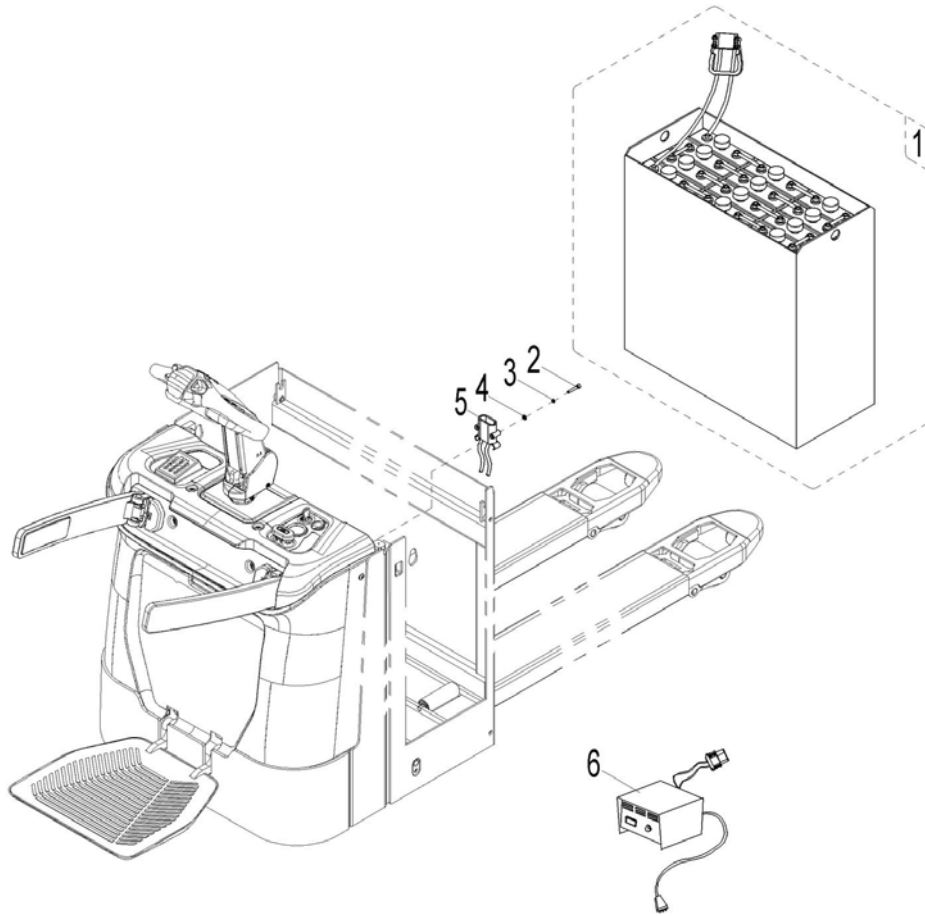

Fig. 29 PT25N Battery Components

No.	Art No.	Description	Qty.	Note
1	505637010000	Traction battery	1	Bolt type
	505637010001	Traction battery	1	Weld type
2	910200200039	Screw	2	M6x30
3	910400500005	Spring washer	2	6
4	910400100005	Flat washer	2	6
5	920400100001	Plug REMA95199-00	1	80A
5	921000200019	Charger 24V/45A	1	Asia Chinese
	921000200020	Charger 24V/45A	1	Asia English
	921000200021	Charger 24V/45A	1	EU
	921000200022	Charger 24V/45A	1	AUS
	921000200023	Charger 24V/45A	1	ENG
	921000200024	Charger 24V/45A	1	US

Fig. 30 Panel components

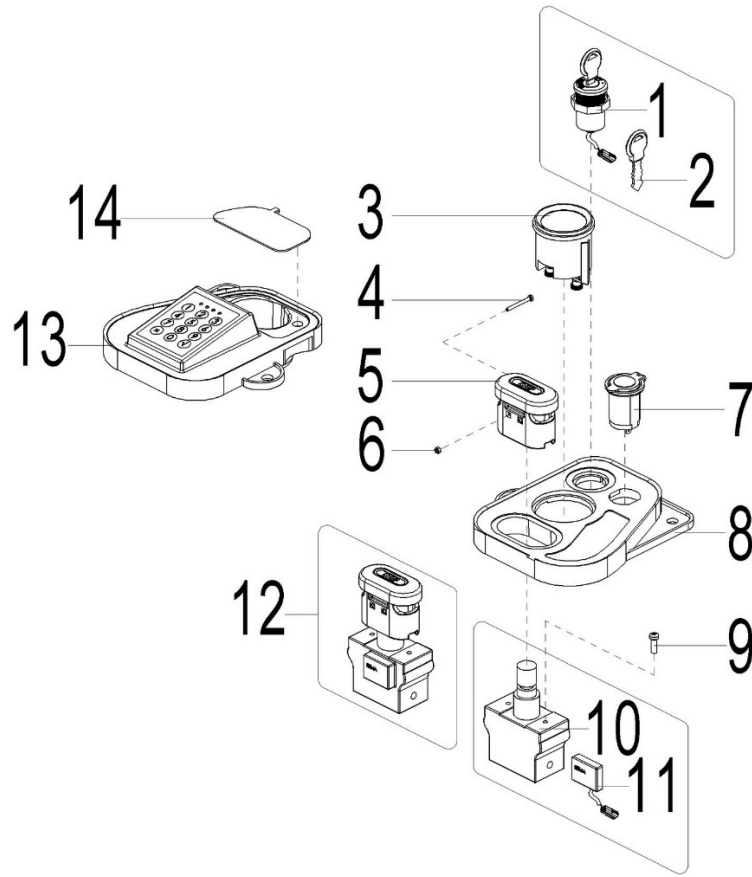

Fig. 30 Panel Components

No	Art No.	Description	Qty	Note
1	50563401000 0	Key switch	1	LKS-101A
	50670203400 1	Key switch function group (Button switch)	1	
2	92020020000 1	Key	1	Only for LKS-101AKey switch
3	92110010001 2	Panel	1	MDI-CAN-12V
4	91020050001 7	Screw	2	M3x30
5	92020010001 0	Emergency switch mounting base	1	ADK350
6	91030010000 2	Nut	2	M3
7	20603301003 6	USB	1	
8	53591002000 1	Panel (Right)	1	
9	91020050004 0	Screw	2	M5x16
10	92020010001 4	Emergency mounting base	1	ADK350
11	92020010001 2	Micro switch	1	ADK350
12	92020010000 9	Emergency switch	1	ADK350
13	53591002000 4	Panel (Left)	1	with pin-code panel
	53591002000 2	Panel (Left)	1	without pin-code panel
14	53591002000 3	Sealing plate	1	Only for Outer charger

Fig. 31 Electrical control components (Manual steering)

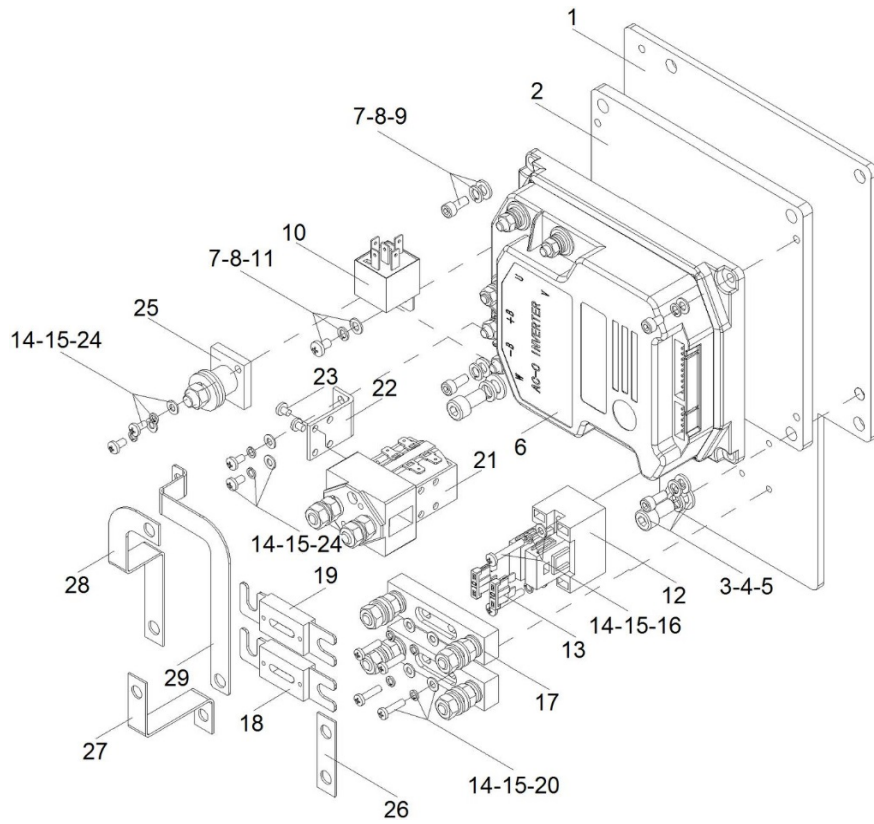

Fig. 31 Electrical Control Components (Manual Steering)

No.	Art No.	Description	Qty.	Note
1	506733020001	Mounting plate	1	Manual steering
2	504433020000	Aluminium	1	AC0
3	910400100006	Flat washer	1	8
4	910400500006	Spring washer	2	8
5	910200200055	Screw	2	M8x16
6	921400100025	Controller AC-0	1	24V200A
7	910400100004	Flat washer	5	5
8	910400500004	Spring washer	5	5
9	910200200023	Screw	4	M5x16
10	920800100001	Relay	1	DC24V-ACR01F-F-1C
11	910200500036	Screw	1	M5x8
12	920100400005	Fuse base	1	BD-2x10A-1
13	920100200002	Fuse	2	10A
14	910400100003	Flat washer	10	4
15	910400500003	Spring washer	10	4
16	910200500028	Screw	2	M4x30
17	920100400002	Fuse base	2	SYX
18	920100100004	Fuse 80A	1	Only for PT20N
	920100100008	Fuse 200A	1	Only for PT25N
19	920100100007	Fuse	1	150A
20	910200500024	Screw	4	M4x16
21	920700100004	Contactor	1	DC24V-C100-120
22	921300400001	Main Contactor fixing parts	1	
23	910200600005	Screw	2	M4x8
24	910200500034	Screw	4	M4x8
25	920100400001	Fuse base	1	M8
26	505633020003	Copper bar	1	
27	505633020002	Copper bar	1	
28	506733020003	Copper bar	1	
29	506733020004	Copper bar	1	

Fig. 32 Electrical control components (EPS)

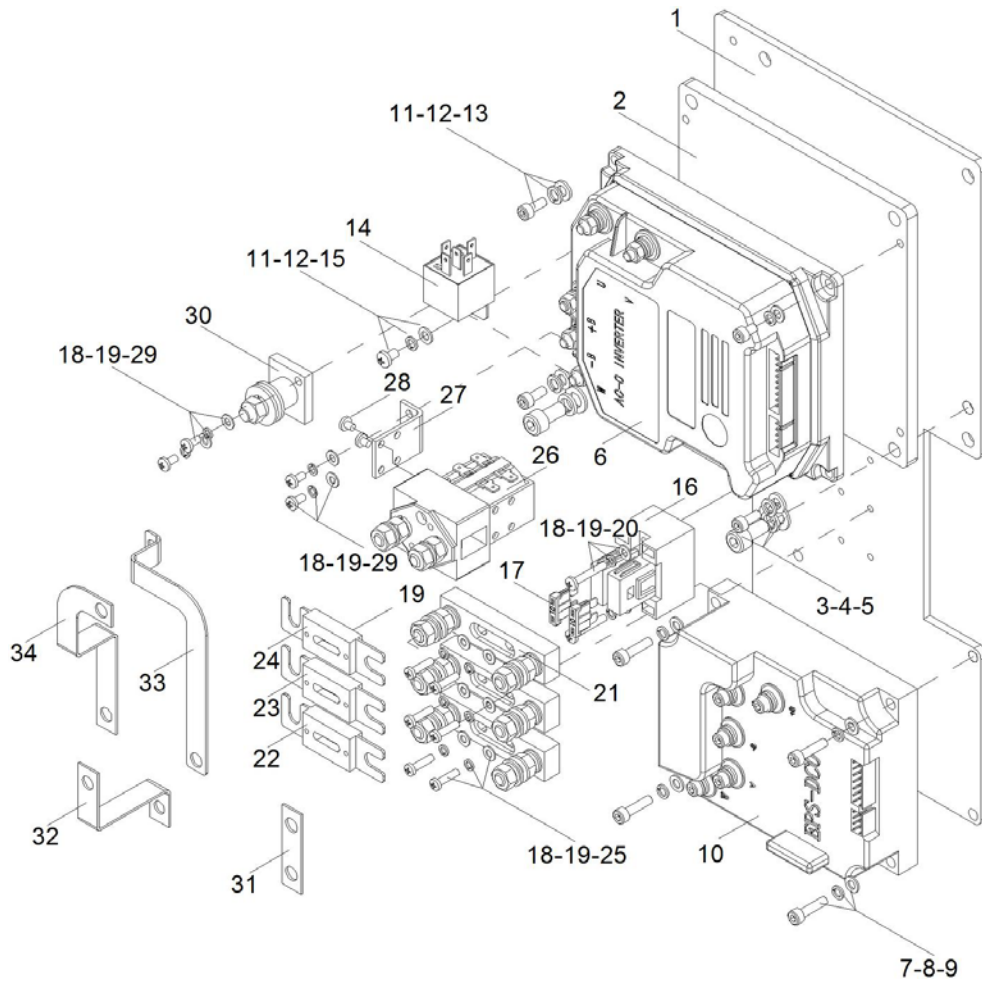

Fig. 32 Electrical Control Components (EPS)

No.	Art No.	Description	Qty.	Note
1	506733020002	Mounting plate	1	EPS
2	504433020000	Aluminium	1	AC0

3	910400100006	Flat washer	2	8
4	910400500006	Spring washer	2	8
5	910200200055	Screw	2	M8x16
6	921400100025	Controller AC-0	1	24V200A
7	910400100005	Flat washer	4	6
8	910400500005	Spring washer	4	6
9	910200200038	Screw	4	M6x25
10	921400100030	Controller EPS-DC0	1	24V-50A
11	910400100004	Flat washer	5	5
12	910400500004	Spring washer	5	5
13	910200200023	Screw	4	M5x16
14	920800100001	Relay	1	DC24V-ACR01F-F-1C
15	910200500036	Screw	1	M5x8
16	920100400005	Fuse base	1	BD-2x10A-1
17	920100200002	Fuse	2	10A
18	910400100003	Flat washer	12	4
19	910400500003	Spring washer	12	4
20	910200500028	Screw	2	M4x30
21	920100400002	Fuse base	2	SY Y
22	920100100001	Fuse	1	30A
23	920100100004	Fuse 80A	1	Only for PT20N
	920100100008	Fuse 200A	1	Only for PT25N
24	920100100007	Fuse	1	150A
25	910200500024	Screw	6	M4x16
26	920700100004	Contactor	1	DC24V-C100-120
27	921300400001	Main contactor fixing parts	1	
28	910200600005	Screw	2	M4x8
29	910200500034	Screw	4	M4x8
30	920100400001	Fuse base	1	M8
31	505633020003	Copper bar	1	
32	505633020002	Copper bar	1	
33	506733020003	Copper bar	1	
34	506733020004	Copper bar	1	

Fig. 33 Main circuit (Manual steering)

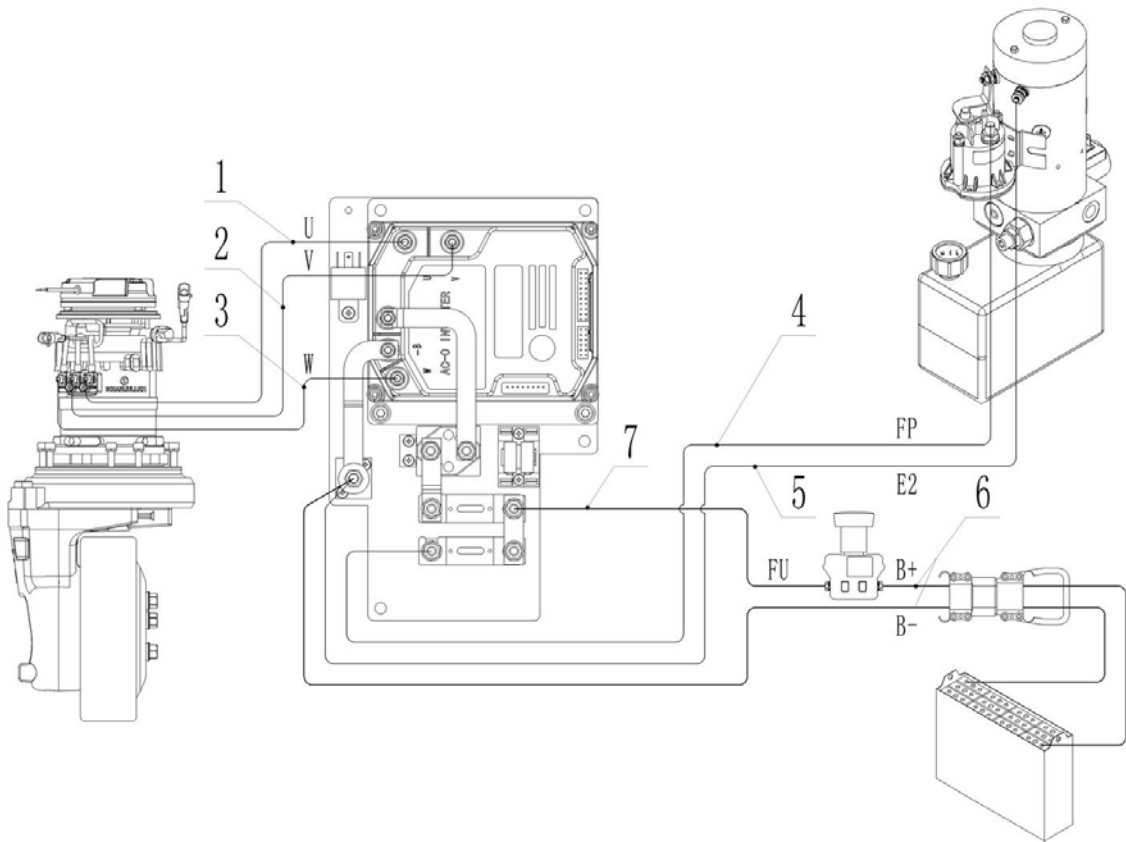

Fig. 33 Main Circuit (Manual steering)

No.	Art No.	Description	Qty.	Note
1	506733010005	Cable -U-16-6-6-600(AC-0)	1	
2	506733010006	Cable -V-16-6-6-650(AC-0)	1	
3	506733010007	Cable -W-16-6-6-650(AC-0)	1	
4	506733010011	Cable -FP-10-8-8-950	1	Only for PT20N
	506933010004	Cable -FP-16-8-8-1020	1	Only for PT25N
5	506733010012	Cable -E2-10-6-8-750	1	Only for PT20N
	506933010005	Cable -E2-16-8-8-950	1	Only for PT25N
6	506733010013	Main Power supply wiring harness	1	
7	506733010014	Cable -FU-25-8-8-580	1	

Fig. 34 Main circuit (EPS)

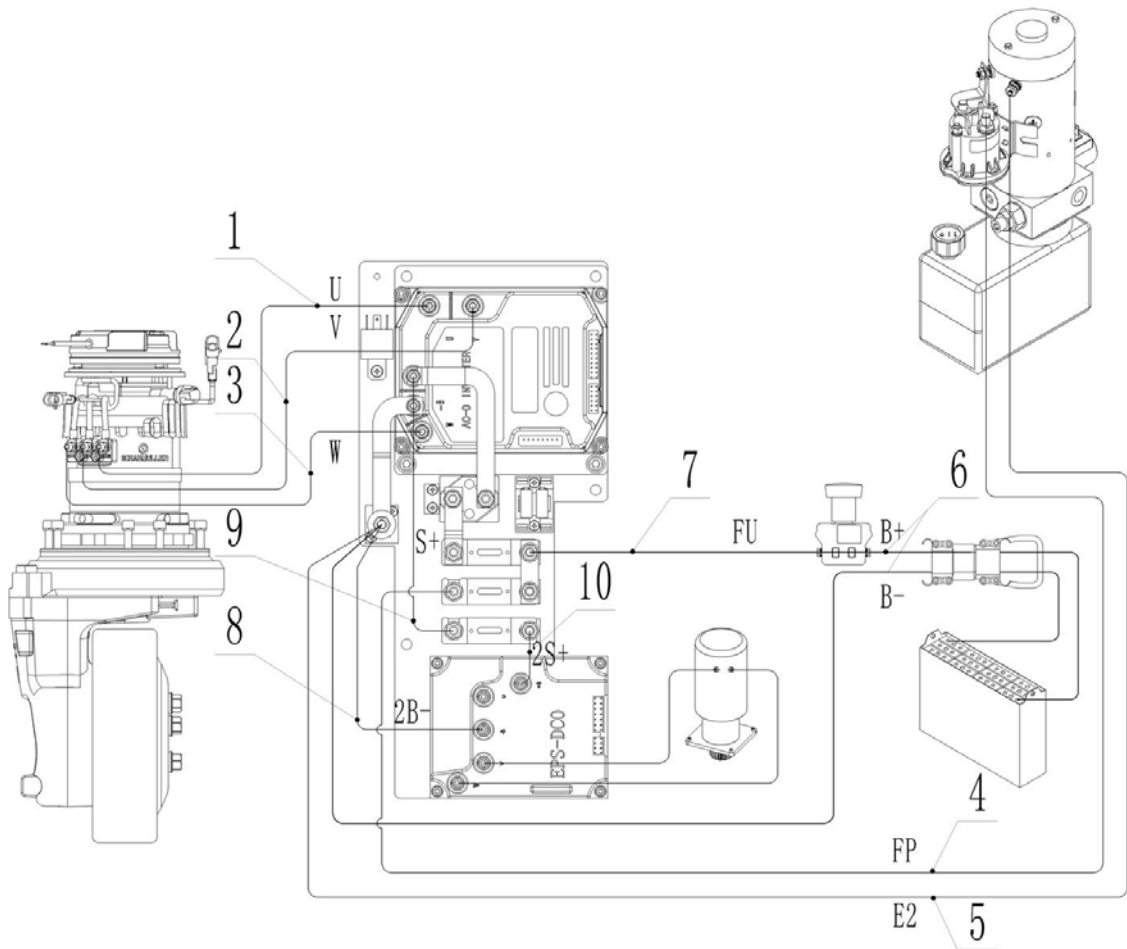

Fig. 34 Main Circuit (EPS)

No.	Art No.	Description	Qty.	Note
1	506733010005	Cable -U-16-6-6-600(AC-0)	1	
2	506733010006	Cable -V-16-6-6-650(AC-0)	1	
3	506733010007	Cable -W-16-6-6-650(AC-0)	1	
4	506733010011	Cable -FP-10-8-8-950	1	Only for PT20N
	506933010004	Cable -FP-16-8-8-1020	1	Only for PT25N
5	506733010012	Cable -E2-10-6-8-750	1	Only for PT20N
	506933010005	Cable -E2-16-8-8-950	1	Only for PT25N
6	506733010013	Main power supply wiring harness	1	
7	506733010014	Cable -FU-25-8-8-580	1	
8	506733010015	Connecting cable -2B--6-5-8-350	1	
9	506733010016	Connecting cable -S+-6-8-8-360	1	
10	506733010017	Connecting cable -2S+-6-5-8-130	1	

Fig. 35 PT20N Sticker

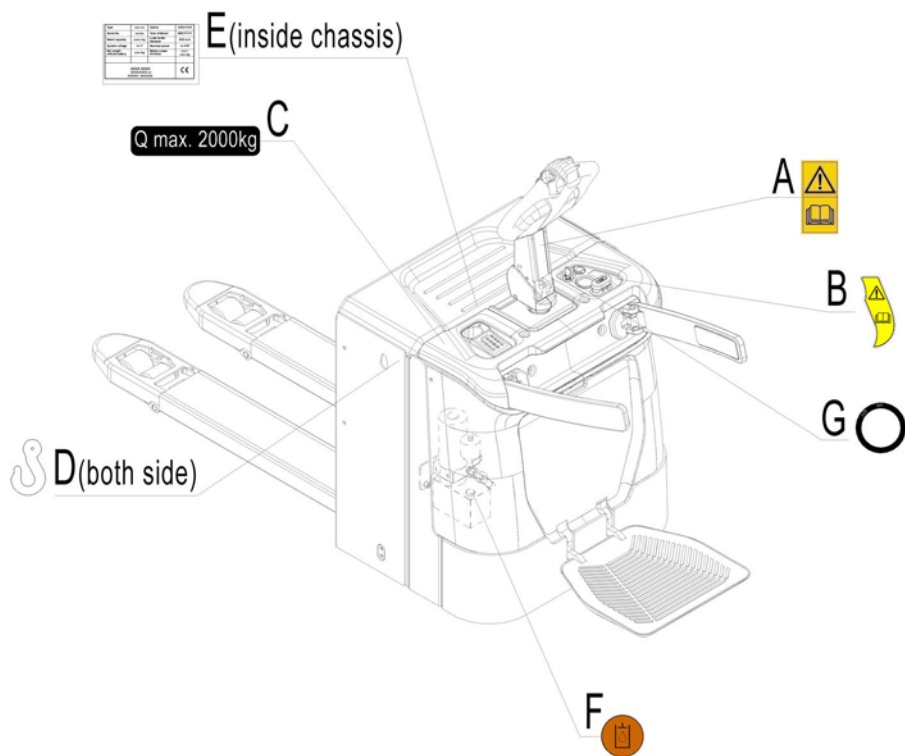

Fig. 35 PT20N Sticker

No.	Art No.	Description	Qty.	Note
A	941200300002	Sticker to read and follow these instructions	1	
B	941200300018	Sticker to read and follow these instructions	1	
C	941200200023	Capacity sticker	1	
D	941200300001	Crane hook label	2	
E	506747520000	CE label	1	
F	941200300003	Filling sticker	1	
G	941200400013	Indicating sticker	1	

Fig. 36 PT25N Sticker

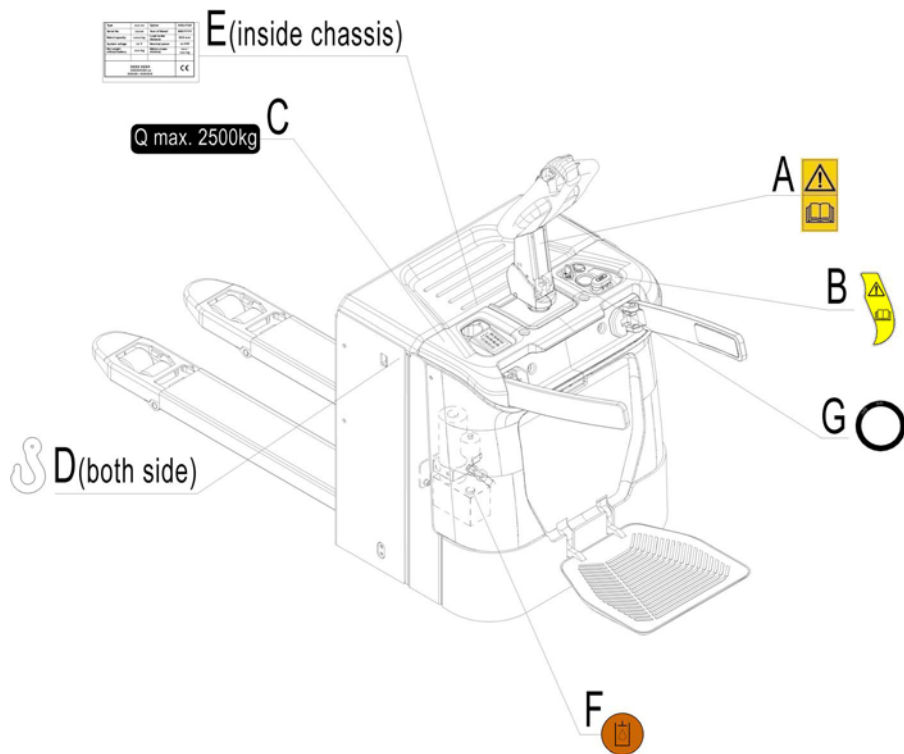

Fig. 36 PT25N Sticker

No.	Art No.	Description	Qty.	Note
A	941200300002	Sticker to read and follow these instructions	1	
B	941200300018	Sticker to read and follow these instructions	1	
C	941200200011	Capacity sticker	1	
D	941200300001	Crane hook label	2	
E	506947520000	CE label	1	
F	941200300003	Filling sticker	1	
G	941200400013	Indicating sticker	1	

Easy worn parts list

No.	Art No.	Description	Qty.	Fig./Position	Note
1	940500100012	Bushing 20x22x12	4	Fig. 1、 2、 3/2	Chassis
2	940500100019	Bushing 20x23x20	2	Fig. 1、 2、 3/13	
3	940500100027	Bushing 25x28x20	2	Fig. 1、 2、 3/14	
4	940500100032	Bushing 25x29x25	2	Fig. 1、 2、 3/15	
5	940500200008	Bushing with shoulder 20x23x16.5	2	Fig. 2、 3/22	
6	506798510000	Push rod kits	2	Fig. 1/12	
7	506798510001	Push rod kits	2	Fig. 1/12	
8	506798510002	Push rod kits	2	Fig. 2/12	
9	506798510003	Push rod kits	2	Fig. 2/12	
10	506798510003	Push rod kits	2	Fig. 3/12	
11	506798510004	Push rod kits	2	Fig. 3/12	
12	940500100012	Bushing 20x22x12	4	Fig. 4/7	Load roller
13	910700200019	Bearing 6204	8/4(Tandem/single)	Fig. 4/10	
14	940300300010	Load roller 84x84	4(Tandem)	Fig. 4/11	
15	940300300006	Load roller 82x110	2(single)	Fig. 4/15	
16	940500200003	Bushing with shoulder 18x20x12	4(Tandem)	Fig. 3/16	
17	505617001000	Load roller assembly	2	Fig. 4/17	
18	505617001001	Load roller assembly	2	Fig. 4/18	
19	502398510003	Entry roller kits	2	Fig. 4/19	
20	505698510003	Roller set kits	4	Fig. 4/20	
21	505698510004	Roller set kits	2	Fig. 4/21	
22	910700500002	Bearing 3205A	2	Fig. 9/2	Steering wheel
23	505616520000	PU spring	2	Fig. 9/8	
24	940500100002	Bushing 12x15x15	4	Fig. 9/9	
25	910700200019	Bearing 6204	4	Fig. 9/15	
26	940300300018	Roller 100x40	2	Fig. 9/16	
27	505698510000	Roller set kits	2	Fig. 9/20	

28	940500100019	Bushing 20x23x20	2	Fig. 10/14, Fig. 11/12	Hydraulic
29	504498520002	Dust ring 50X58X5/6.5	1	Fig. 12/2	Cylinder
30	504498520001	Y Sealing ring 50X60X6/7	1	Fig. 12/3	
31	504498520000	Support ring 50x55x15	1	Fig. 12/4	
32	504498510000	Sealing kits	1	Fig. 12/6	
33	940500200002	Bushing with shoulder 17x19x11	2	Fig. 15/17	Tiller
34	940400100001	Air spring 330N	1	Fig. 15/12	
35	940500200008	Bushing with shoulder 20x23x16.5	2	Fig. 21/3	Platform
36	940400100038	Air spring 800N	1	Fig. 21/12	
37	535918020018	PU bushing 29x19x48	2	Fig. 21/21	
38	940400100037	Air spring 250N	1	Fig. 22/2	Protective arm
39	940500200003	Bushing with shoulder 18x20x12	4	Fig. 22/7	
40	920200300003	Micro switch RZ-15GW2S-B3	1	Fig. 26/2	Electrical components
41	920100200002	Fuse 10A	2	Fig. 31/13	Electrical control
42	920100100004	Fuse 80A	1	Fig. 31/18	
43	920100100007	Fuse 150A	1	Fig. 31/19	
44	920100200002	Fuse 10A	2	Fig. 32/17	
45	920100100001	Fuse 30A	1	Fig. 32/22	
46	920100100004	Fuse 80A	1	Fig. 32/23	
47	920100100007	Fuse 150A	1	Fig. 32/24	