

INSTRUCTION HANDBOOK

Electric Pallet Truck

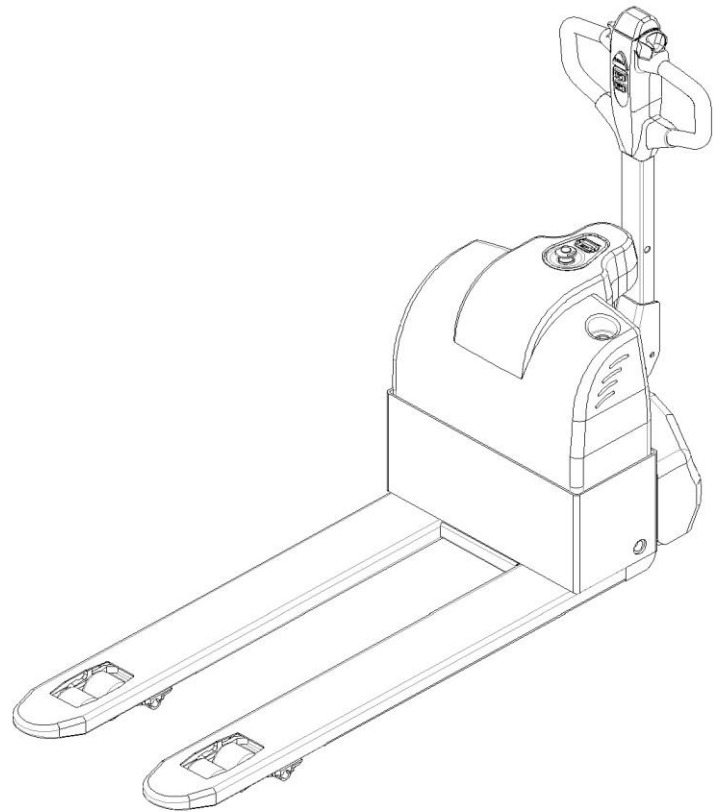

WARNING

Do not use the pallet truck before reading and understanding these operating instructions.

NOTE:

- **Please check the designation of your present type at the last page of this document as well as on the ID-plate.**
- **Keep for future reference.**

Version 07/2014

EPT-SPT-SMS-004-EN

FOREWORD

Before operating the truck, read this ORIGINAL INSTRUCTION HANDBOOK carefully and understand the usage of the truck completely. Improper operation could create danger.

This handbook describes the usage of different electric pallet trucks. When operating and servicing the truck, make sure, that it applies to your type.

Keep this handbook for future reference. If this or the warning/ caution labels are damaged or got lost, please contact your local dealer for replacement.

This truck complies with the requirements according to EN 3691-1; -5 (Industrial trucks- safety requirements and verification, part 1; part 5), EN 12895 (Industrial trucks- electromagnetic compatibility), EN 12053 (Safety of industrial trucks- test methods for measuring noise emissions), EN 1175 (Industrial truck safety – electrical requirements), assumed the truck is used according to the described purpose.

The noise level for this machine is 69 dB(A) according to EN 12053.

ATTENTION:

- Environmentally hazardous waste, such as batteries, oil and electronics, will have a negative effect on the environment, or health, if handled incorrectly.
- The waste packages should be sorted and put into solid dustbins according to the materials and be collected disposal by local special environment protection bureau. To avoid pollution, it's forbidden to throw away the wastes randomly.
- To avoid leaking during the use of the products, the user should prepare some absorbable materials (scraps of wooden or dry duster cloth) to absorb the leaking oil in time. To avoid second pollution to the environment, the used absorbable materials should be handed in to special departments in terms of local authorities.
- Our products are subject to ongoing developments. Because this handbook is only for the purpose of operating /servicing the pallet truck, therefore please have understanding, that there is no guarantee out of particular features out of this handbook.



NOTE: On this manual, the left sign means warning and danger, which can lead to death or serious injury if not followed.

Copyright

The copyright remains with the company, mentioned on the CE- certificate at the end of this document.

TABLE OF CONTENTS

| | |
|--|----|
| 1. CORRECT APPLICATION | 4 |
| 2. DESCRIPTION OF THE PALLET TRUCK | 5 |
| a. Overview of the main components | 5 |
| b. Main technical data | 5 |
| c. Description of the safety devices and warning labels..... | 7 |
| d. Identification plate | 7 |
| 3. WARNINGS, RESIDUAL RISK AND SAFETY INSTRUCTIONS | 8 |
| 4. COMMISSIONING, TRANSPORTING, DECOMMISSIONING | 9 |
| a. Commissioning | 9 |
| b. Tiller assembly (only SPT 15) | 9 |
| c. Lifting/ transportation..... | 11 |
| d. Decommissioning..... | 11 |
| 5. DAILY INSPECTION | 11 |
| 6. OPERATING INSTRUCTIONS | 12 |
| a. Parking..... | 12 |
| b. Lifting | 13 |
| c. Lowering | 13 |
| d. Travelling | 13 |
| e. Steering..... | 14 |
| f. Braking..... | 14 |
| g. Malfunctions..... | 15 |
| h. Emergency..... | 15 |
| 7. BATTERY CHARGING AND REPLACEMENT..... | 15 |
| a. Replacement..... | 16 |
| b. Battery indicator | 17 |
| c. Charging..... | 17 |
| 8. REGULAR MAINTENANCE..... | 18 |
| a. Maintenance checklist..... | 18 |
| b. Lubricating points | 20 |
| c. Check and refill hydraulic oil | 20 |
| d. Checking electrical fuses | 21 |
| 9. TROUBLE SHOOTING | 23 |
| 10. WIRING/ CIRCUIT DIAGRAM..... | 24 |
| a. Electrical circuit diagram | 24 |
| b. Hydraulic circuit..... | 26 |
| 11. DECLARATION OF CONFORMITY (valid, if sold within the EU) | 27 |

1. CORRECT APPLICATION

It is only allowed to use this electric pallet truck according to this instruction handbook.

The in this handbook described trucks are self propelled electric power pallet trucks, with electrically or manually operated low height lifting function. The trucks are designed to lift, lower and transport palletized loads.

A wrong usage can cause human injuries or can damage equipment.

The operator/ the operating company has to ensure the correct usage and has to ensure, that this pallet truck is used only by staff, which is trained and authorized to use this truck.

The pallet truck has to be used on substantially firm, smooth, prepared, level and adequate surfaces. The truck is intended to be used for indoor applications with ambient temperatures between +5°C and + 40°C and for light duty applications without crossing permanent obstacles or potholes. Operating on ramps is not allowed. While operating, the load must be placed approximately on the longitudinal centre plane of the truck. Lifting or transporting people is forbidden.

If used on tail lifts or loading ramps, please ensure that these are used correctly according to the operating instructions.

The capacity is marked on capacity sticker as well on the Identification plate. The operator has to consider the warnings and safety instructions.

Operating lighting must be minimum 50 Lux.

Modification

No modifications or alterations to this pallet truck which may affect, for example, capacity, stability or safety requirements of the truck, shall be made without the prior written approval of the original truck manufacturer, its authorized representative, or a successor thereof. This includes changes affecting, for example braking, steering, visibility and the addition of removable attachments. When the manufacturer or its successor approve a modification or alteration, they shall also make and approve appropriate changes to capacity plate, decals, tags and operation and maintenance handbooks.

By not observing these instructions, the warranty becomes void.

2. DESCRIPTION OF THE PALLET TRUCK

a. Overview of the main components

- 1 Multifunction tiller
- 2 Discharge indicator and charging indicating LED
- 3 Combined emergency button
- 4 Main cover
- 5 Fork chassis
- 6 Load wheels
- 7 Charging cable
- 8 Drive motor cover
- 9 Hydraulic cylinder
- 10 Drive wheel
- 11 Castors
- 12 Safety (belly) button
- 13 Drive control switch (butterfly-switch)

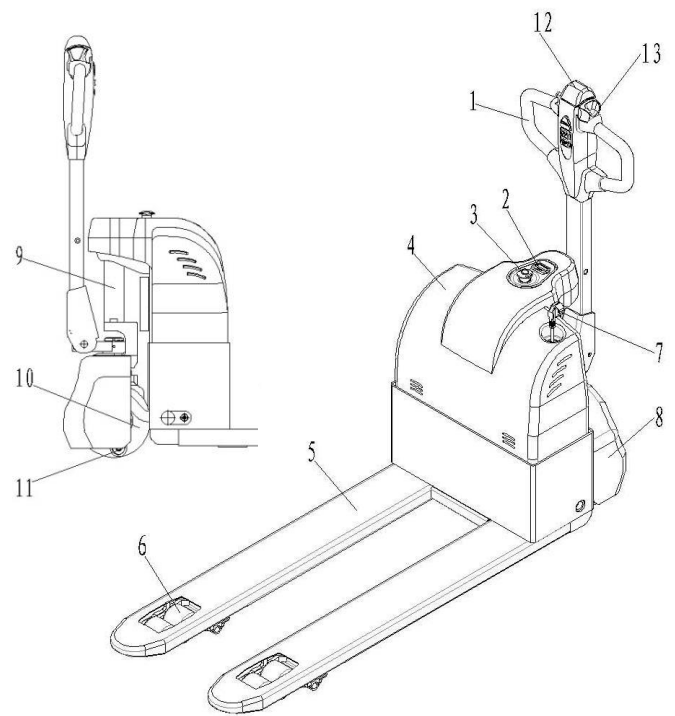

Fig. 1: Overview main components

b. Main technical data

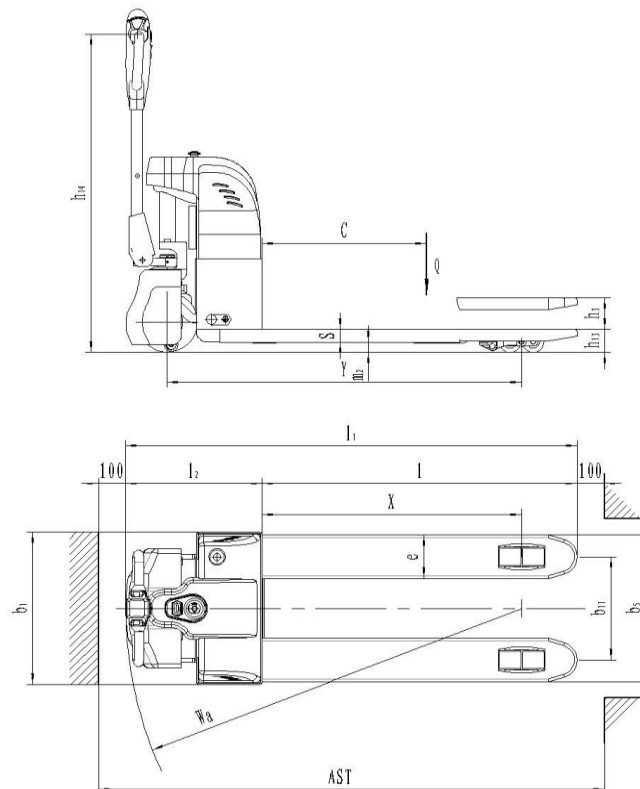

Fig. 2: Technical data

Table 1: Main technical data for standard version

| Type sheet for industrial truck acc. to VDI 2198 | | | | | |
|--|------|---|---|--------------------------|------------|
| Distinguishing mark | 1.2 | Manufacturer`s type designation | | EPT15 | SPT 15 |
| | 1.3 | Drive | | Electric | |
| | 1.4 | Operator type | | Pedestrian | |
| | 1.5 | Load Capacity / rated load | Q (t) | 1.5 | |
| | 1.6 | Load centre distance | c (mm) | 600 | |
| | 1.8 | Load distance ,centre of drive axle to fork | x (mm) | 946 | |
| | 1.9 | Wheelbase | y (mm) | 1293 | 1279 |
| Weight | 2.1 | Service weight | kg | 190 | 165 |
| | 2.2 | Axle loading, laden front/rear | kg | 510/1180 | 458/1207 |
| | 2.3 | Axle loading, unladen front/rear | kg | 1550/40 | 130/35 |
| Tyres, chassis | 3.1 | Tires | | Polyurethane (PU) | |
| | 3.2 | Tire size, front | ∅ x w (mm) | ∅ 220x70 | |
| | 3.3 | Tire size, rear | ∅ x w (mm) | ∅ 80x70 | |
| | 3.4 | Additional wheels(dimensions) | ∅ x w (mm) | ∅50(80) ¹ x30 | ∅50x30 |
| | 3.5 | Wheels, number front/rear(x=driven wheels) | | 1x +2/ 4 | |
| | 3.6 | Tread, front | b ₁₀ (mm) | 340(410) ¹ | 340 |
| | 3.7 | Tread, rear | b ₁₁ (mm) | 380 | |
| Dimensions | 4.4 | Lift | h ₃ (mm) | 115 | |
| | 4.9 | Height of tiller in drive position min./ max. | h ₁₄ (mm) | 800 / 1170 | 850 / 1295 |
| | 4.15 | Height, lowered | h ₁₃ (mm) | 85 (80) | |
| | 4.19 | Overall length | l ₁ (mm) | 1648(1660) ¹ | 1666 |
| | 4.20 | Length to face of forks | l ₂ (mm) | 498(510) ¹ | 516 |
| | 4.21 | Overall width | b ₁ (mm) | 560(574) ¹ | 560 |
| | 4.22 | Fork dimensions | s/e/l (mm) | 48/160/ | |
| | 4.25 | Distance between fork- arms | b ₅ (mm) | 540 (520) | |
| | 4.32 | Ground clearance, centre of wheelbase | m ₂ (mm) | 37(32) | |
| | 4.34 | Aisle width for pallets 800X1200 lengthways | Ast (mm) | 1950 | 1961 |
| | 4.35 | Turning radius | Wa (mm) | 1445 | 1507 |
| Performance data | 5.1 | Travel speed, laden/ unladen | km/h | 4.2 / 4.6 | |
| | 5.2 | Lift speed, laden/ unladen | m/s | 0.03 / 0.053 | - |
| | 5.3 | Lowering speed, laden/ unladen | m/s | 0.049 / 0.036 | - |
| | 5.8 | Max. gradeability, laden/ unladen | % | 4 / 10 | |
| | 5.10 | Service brake | | Electromagnetic | |
| Electric- engine | 6.1 | Drive motor rating S2 60min | kW | 0.45 | |
| | 6.2 | Lift motor rating at S3 10% | kW | 0.8 | - |
| | 6.3 | Battery acc. to DIN 43531/ 35/ 36 A, B, C, no | | No | No |
| | 6.4 | Battery voltage, nominal capacity K5 | V/ Ah | 2x12V / 64 | 2x12 / 40 |
| | 6.5 | Battery weight | kg | 48 | 30 |
| | 6.6 | Energy consumption acc. to VDI cycle | kWh/h | 0,39 | - |
| Addition data | 8.1 | Type of drive control | | DC- Speed Control | |
| | 8.4 | Sound level at driver`s ear acc. to EN 12053 | dB(A) | 69 | |
| Note: 1) For option suspension castors | | | Note: 2) Available fork length: 800, 1000, 1150, 1220mm | | |

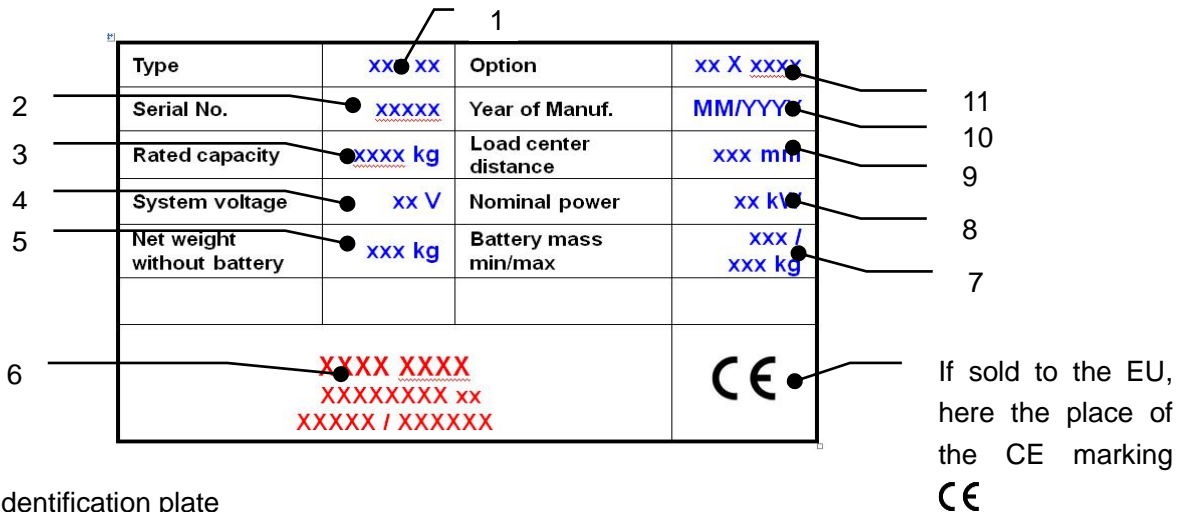

Fig. 4: Identification plate

3. WARNINGS, RESIDUAL RISK AND SAFETY INSTRUCTIONS



DO NOT

- Put foot or hand under or into the lifting mechanism.
- Allow other person than the operator to stand in front of or behind the truck when it is moving or lifting/lowering.
- Overload the truck.
- Put foot in front of the wheels, injury could result.
- Lift people. People could fall down and suffer severe injury.
- Push or pull loads
- Use this truck on ramps
- Side or end load. Load must be distributed evenly on the forks.
- Use the truck with unstable, unbalanced not stable load.
- Use truck without manufacturer's written consent.
- Supply on board charger with AC voltage other than 110V or 220V.

Watch difference in floor levels when driving. Load could fall down or the truck could get uncontrollable.

Keep watching the condition of load. Stop operating the truck if load becomes unstable. Brake the truck and activate the emergency switch (3) by pushing when sliding load on or off the truck. If the truck has any malfunctions, follow chapter 8.

Practice maintenance work according to regular inspection. This truck is not designed to be water resistant. Use the truck under dry condition. Prolonged continuous operation might cause damage of the power pack. Stop operation if temperature of hydraulic oil is too high.



- When operating the electric pallet truck, the operator has to wear safety shoes.
- The truck is intended to be used for indoor applications with ambient temperatures

between +5°C and + 40°C.

- The operating lighting must be minimum 50 Lux.
- It is not allowed to use the truck on ramps.
- To prevent unintended sudden movements when not operating the truck (i.e. from another person, etc.) switch off the truck when not operating it.

4. COMMISSIONING, TRANSPORTING, DECOMMISSIONING

a. Commissioning

Table 2: Commissioning data

| Type | SPT 15 | EPT 15 |
|---------------------------|--------------|--------------|
| Commissioning weight [kg] | app. 205 kg | app. 230 kg |
| Dimensions [mm] | 1750x700x900 | 1750x700x900 |

After receiving our new pallet truck or for re-commissioning you have to do following before (firstly) operating the truck:

- Check if are all parts included and not damaged
- Eventually installation of the multifunction tiller
- Eventually installation and charging the batteries (follow chapter 7)
- Do the work according to the daily inspections as well as functional checks.

If the tiller arm is not assembled to your truck, please make sure, that the following supplied parts are included and not damaged:

b. Tiller assembly (only SPT 15)

- 1 pc drilled axle (4)
- 2 pc dowel pin (5) [one is already assembled with the axle]
- 1 pc pre- assembled tiller arm (1)
- 1 pc pre- assembled chassis (6) with screw (2) and nut (3)

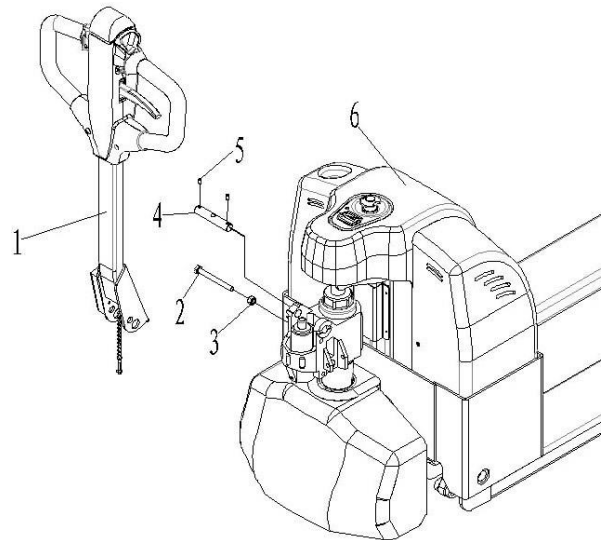

Fig. 5: SPT 15 tiller assembling

Note: The marked number on the tiller arm package and the chassis should be the same.

When attaching the handle, you had better squat just in front of the pallet truck.

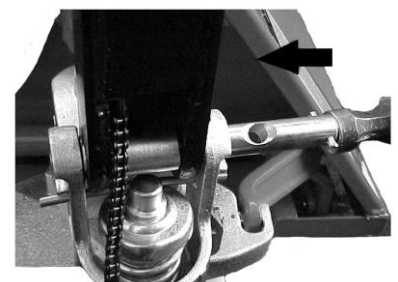

Fig. 6: Axle assembling

- a) Insert the tiller arm(1) into the pump piston, then use a hammer to insert the axle with hole into the hydraulic pump

and tiller arm (fig.6).

- b) Set the control lever of the handle to the 'Lower' position, then pass the adjusting nut, adjusting bolt through the hole of the axle with your hand (fig. 7).
- c) Press the tiller arm down; unscrew and remove the screw (2) and the nut (3) (fig. 5).
- d) Set the control lever (fig. 8) of the handle to 'RAISE' position, then raise the lever plate and insert the adjusting bolt into the front slot of lever plate. Note: Keep the adjusting nut under the lever plate. (fig. 7)
- e) Use a hammer to insert the 2nd dowel pin (5, fig. 5) into the 2nd hole of the axle.
- f) Unscrew the protective cover for the tiller arm switch on the left side of the tiller.
- g) Connect the plugs for the electric function of the tiller and fix the cable with the cable fixing element)
- h) Assemble the protective cover for the tiller arm switch.

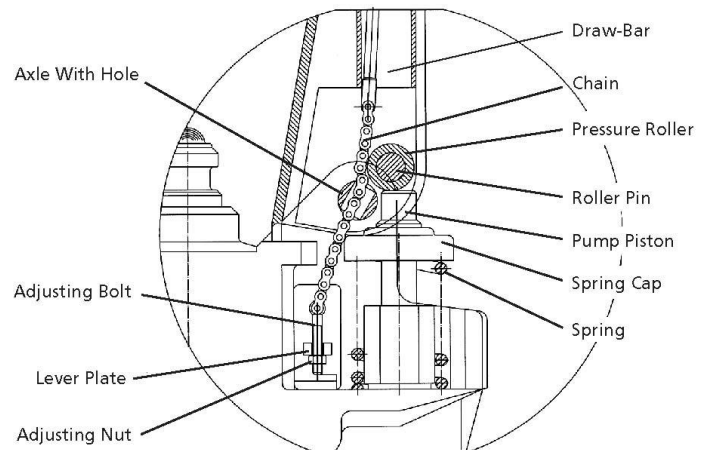

Fig. 7: Side view

The draw-bar is now assembled to the pump.

Hydraulic valve adjustment (only SPT 15)

The SPT 15 multifunction tiller can be regulated in three positions (fig. 8):

- Lower** : handle up, the lever moves back to the neutral, when released
- Neutral**: handle in center position
- Raise**: handle down

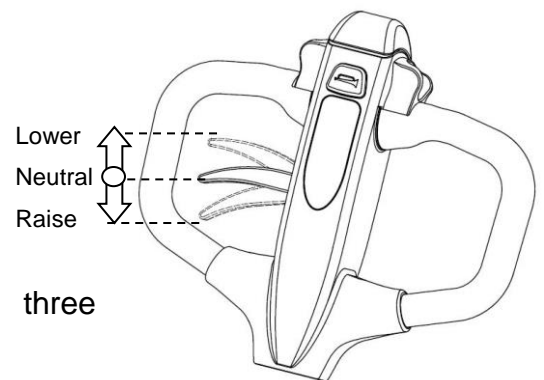

Fig. 8: SPT 15 tiller

If necessary, you can adjust the lever according to following steps (fig. 7):

- a) If the forks elevate while pumping in the **Raise** position, turn the adjusting nut on the adjusting bolt clockwise until pumping action does not raise the forks and the **Neutral** position works properly.
- b) If the forks descend while pumping in the **Neutral** position, turn the adjusting nut counter-clockwise until the forks do not lower.
- c) If the forks do not descent when the control handle is in the **Lower** position, turn the adjusting nut clockwise until raising the control handle lowers the forks. Then check the **Neutral** position and ensure that the adjusting nut is in the proper position.
- d) If the forks do not elevate while pumping in the **Raise** position, turn the adjusting nut counter-clockwise until the forks elevate while pumping in the **Raise** position. Then check the **Lower** and **Raise** position.

c. Lifting/ transportation

For transporting, remove the load, lower the forks to the lowest position and fix the truck safe with dedicated lifting gear according to the following figures.

Lifting



USE DEDICATED CRANE AND LIFTING EQUIPMENT
DO NOT STAND UNDER THE SWAYING LOAD
DO NOT WALK INTO THE HAZARDOUS AREA DURING LIFTING

Park the truck securely and lash the truck according to the points identified in fig. 9

Lift the truck to its destination and place the truck securely before removing the lifting gear.

The lashing points are according to the fig. 9.

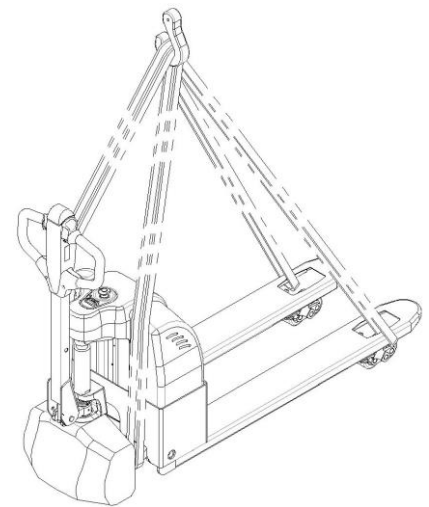

Fig. 9: Lifting with a crane

Transportation



DURING TRANSPORTATION ON A LORRY OR TRUCK ALWAYS FASTEN THE TRUCK SECURELY

Lower the forks and park the truck securely.

Fasten the truck according to fig. 10 by slinging dedicated lashing belts around both sides of the trucks torsion arms and fasten the other side at the transporting truck.

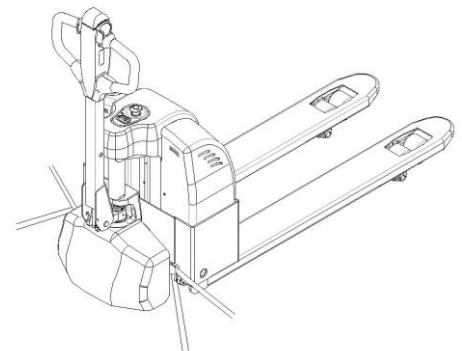

Fig. 10: fixing points

d. Decommissioning

For storage, remove the load, lower the truck to the lowest position, grease all in this handbook mentioned greasing points (regular inspection), eventually protect the truck against corrosion and dust. Remove the batteries and jack the truck safety, so that there will be no flattening after storage.

For final decommissioning hand the truck to a designated recycling company. Oil, batteries and electric components must be recycled due to legal regulations.

5. DAILY INSPECTION

This chapter describes pre-shift checks before putting the truck into operation.

Daily inspection is effective to find the malfunction or fault on this truck. Check the truck on the following points before operation.

Remove load from truck and lower the forks.



DO NOT USE THE TRUCK IF ANY MALFUNCTION IS FOUND.

- Check for scratches, deformation or cracks.
- Check if there is any oil leakage from the cylinder.
- Check the vertical creep of the truck.
- Check the smooth movement of the wheels.
- Check the function of the emergency brake by activating the emergency button.
- Check, the tiller arm- switch braking function
- Check the lifting and lowering functions by operating the buttons.
- Check if all bolts and nuts are tightened firmly.
- Visual check if there are any broken hoses or broken electric wires.

6. OPERATING INSTRUCTIONS



BEFORE OPERATING THIS TRUCK, PLEASE FOLLOW THE WARNINGS AND SAFETY INSTRUCTIONS (CHAPTER 3).

Make sure, that the load is palletized and stable and that the daily inspection is carried out.

Insert the key of the combined emergency switch, turn it 90° clockwise and pull the button up. The key can be used only on this kind of pedestrian power pallet truck.

Press the horn button (16) to activate the audible warning signal.

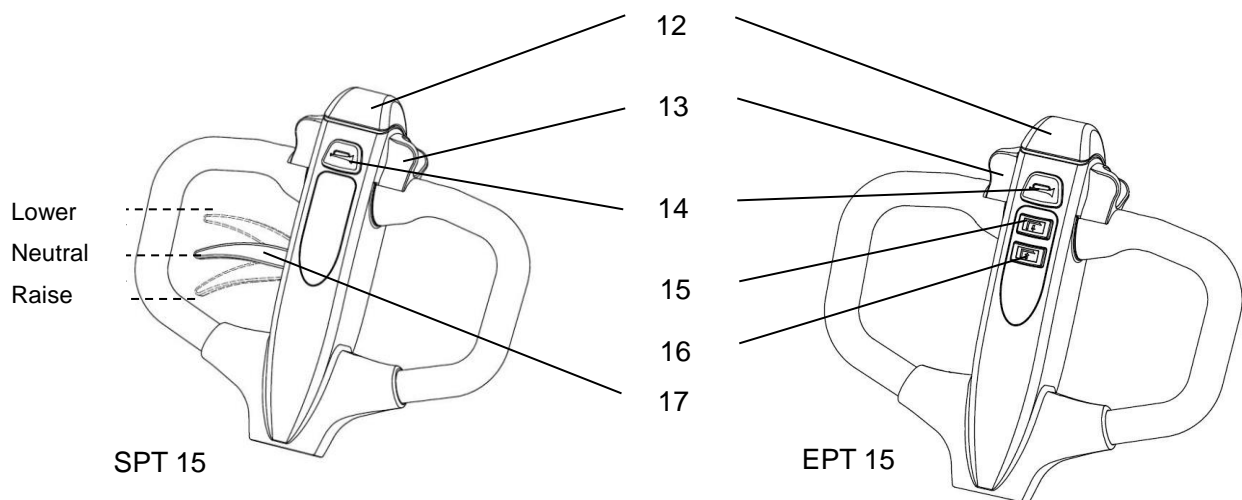

Fig.11: Tiller operating controls

a. Parking



DO NOT PARK THE TRUCK ON INCLINED SURFACES

The truck is equipped with an electromagnetic failsafe stopping and parking brake. Always lower the forks fully. Press the combined emergency switch (3), turn the key 90° anti- clockwise and remove the key.

b. Lifting



DO NOT OVERLOAD THE TRUCK! THE MAXIMUM CAPACITY IS 1500 kg

EPT 15

Travel with the lowered forks fully underneath the pallet until the load and press the lifting button (15) until you reached the desired lifting height.

SPT 15

Travel with the lowered forks fully underneath the pallet and shift operating lever (17) down to the raise position. Lift the load by up- and down movements of the tiller arm until you reached the desired lifting height.

c. Lowering

EPT 15

Press the lowering button (16) carefully.

Lower the load until the forks are clear of the pallet, then drive the truck carefully out of the load unit.

SPT 15

Lower the load by shift the operating lever (17) up to the lowering position carefully. By releasing the lever, the lowering movement will stop. Ensure that there is adequate clearance behind, then drive the truck carefully out of the load unit.

d. Travelling



TRAVEL ON INCLINES ONLY WITH THE LOAD FACING UPHILL.

DO NOT TRAVEL ON INCLINES MORE THAN SPECIFIED WITH THE TECHNICAL DATA.

After starting the truck by pulling the combined emergency switch (3), move the tiller to the operating zone ('F', fig.13).

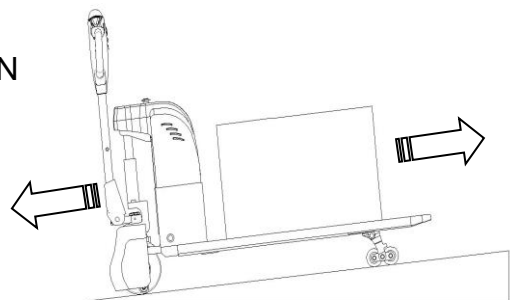

Turn the accelerator button to the desired direction forward 'Fw.' or backwards Bw.'(fig. 13).

Fig. 12: Load facing uphill

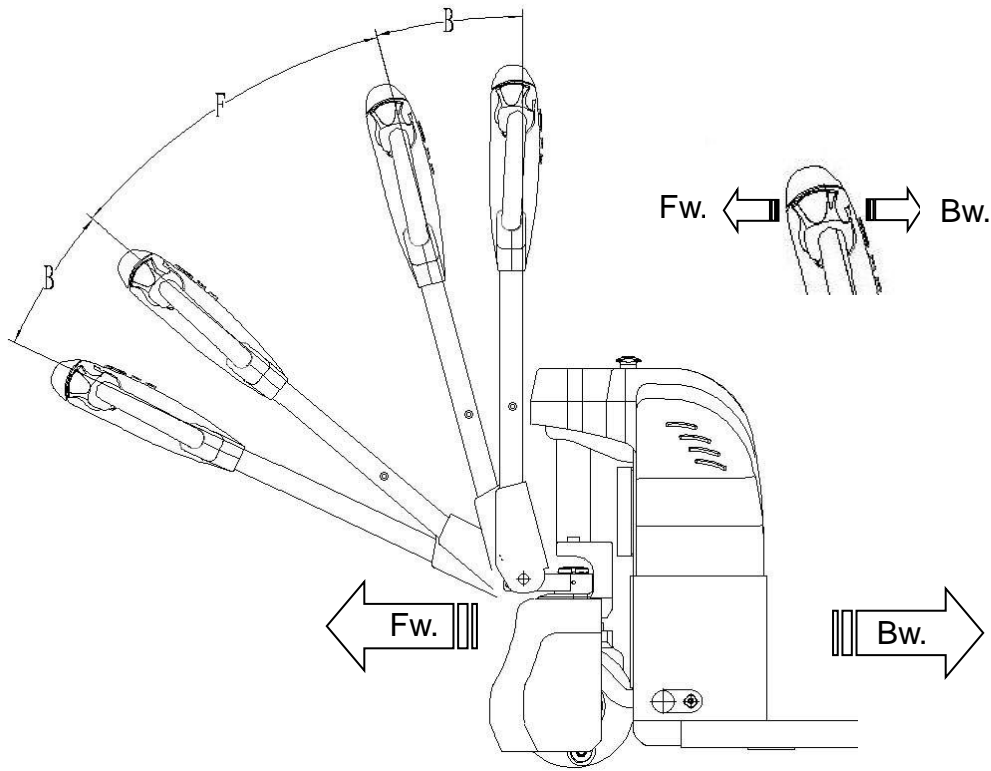

Fig. 13: Operating direction

Control the travelling speed by moving the accelerator button(13) carefully until you reached the desired speed.

If you move the accelerator button back to the neutral position, the controller decelerates the truck until the truck stops. If the truck stopped, the parking brake will be engaged.

Drive carefully the truck to the destination. Watch the route conditions and adjust the travelling speed with the accelerator- button.

e. Steering

You steer the truck by moving the tiller to the left or right side.

f. Braking



THE BRAKING PERFORMANCE DEPENDS ON THE TRACK CONDITIONS AND TRHE LOAD CONDITONS OF THE TRUCK

The braking function can be activated on several ways:

- By moving the accelerator button (13) back to the initial '0' position or by releasing the button, the regenerative braking is activated. The truck brakes until it stops.
- By moving the accelerator button (13) from one driving direction directly to the opposite direction, the truck brakes regenerative until it starts travelling into the opposite direction.
- The truck brakes, if the tiller is moved up or down to the braking zones ('B'). If the

tiller is released, the tiller moves automatically up to the upper baking zone('B').
The truck brakes until it stops.

- The safety (belly) button (12) prevents the operator from being crushed. If this button is activated, the truck decelerates and or starts travelling into the backwards direction ('Bw.')

g. Malfunctions

If there are any malfunctions or the truck is inoperative, please stop using the truck and activate the emergency switch (3) by pushing it. If possible, park the truck on a safe area and remove the combined locking key from the combined emergency switch (3). Inform immediately the manager and, or call your service.

h. Emergency

In emergencies, push the combined emergency switch (3). All electrical functions will be stopped. Keep safe distance.

7. BATTERY CHARGING AND REPLACEMENT



- Only qualified personnel are allowed to service or charge the batteries. The instructions of this handbook and from the battery- manufacturer must be observed.
- These batteries are maintenance free; re- filling is prohibited.
- Recycling of batteries undergoes national regulations. Please follow these regulations.
- By handling batteries, open fire is prohibited, gases could cause explosion!
- In the area of battery charging neither burning materials nor burning liquids are allowed. Smoking is prohibited and the area must be ventilated.
- Park the truck securely before starting charging or installing/changing the batteries
- Before finishing the maintenance work, make sure, that all cables are connected correctly and that there are no disturbing towards other components of the truck.

As standard batteries, the truck is equipped with following sealed liquid acid battery- types:

- SPT 15: 2 pc 12V/ 40Ah(C5) (optional 2 pc 12V/ 60Ah)
- EPT 15: 2 pc 12V/ 60Ah (optional 2 pc 12V/80Ah)



IT IS ONLY ALLOWED TO USE SEALED LIQUID ACID BATTERIES.

THE WEIGHT OF THE BATTERIES HAS AN INFLUENCE TO THE TRUCKS OPERATING BEHAVIOR.

PLEASE CONSIDER THE MAXIMUM OPERATING TEMPERATURE OF THE BATTERIES.

a. Replacement

Park the truck securely and switch off the truck with the combined emergency switch (3). Loosen the main cover with the 2 screws (18, fig. 14).



EPT 15:
REMOVE THE OIL FILLING CAP AND USE THE WITH THIS HANDBOKK SUPPLIED CLOSING CAP (21) TO CLOSE THE HYDRAULIC TANK COMPLETELY. AFTER MAINTENANCE, KEEP THE CLOSING CAP FOR FURTHER USAGE (ONLY EPT 15!).

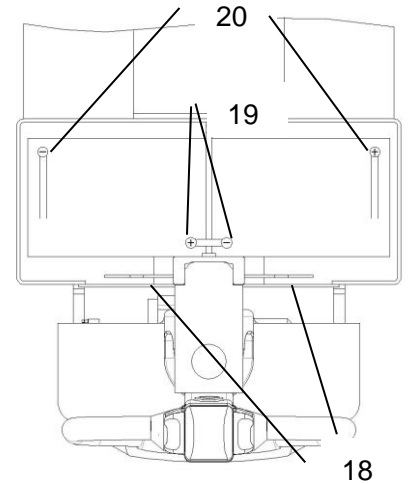

Fig. 14: Battery replacement

After closing the hydraulic tank with the closing cap (21, fig. 15, only EPT 15), unbolt the the screws of the negative terminal (19, fig. 14) firstly, then unbolt the screws of the positive terminal (20, fig. 14) and put the cables aside.

Unbolt the lower screws of the electric assembly board (22, fig. 15). Then unbolt the 2 fixing screws (23).

Then rotate the assembly around the 2nd fixing screws (24) and secure it against falling with the safety bar (25).

Remove the battery fixing elements (26, fig. 15) and remove the batteries. Place the new batteries with the terminal- positions according to fig. 14.

The installation is in the reverse order of the removal. Please connect the positive terminals firstly, otherwise the truck could be damaged.

Before fixing the main cover, remove the closing cap (21, only EPT 15) and assemble the standard cap.

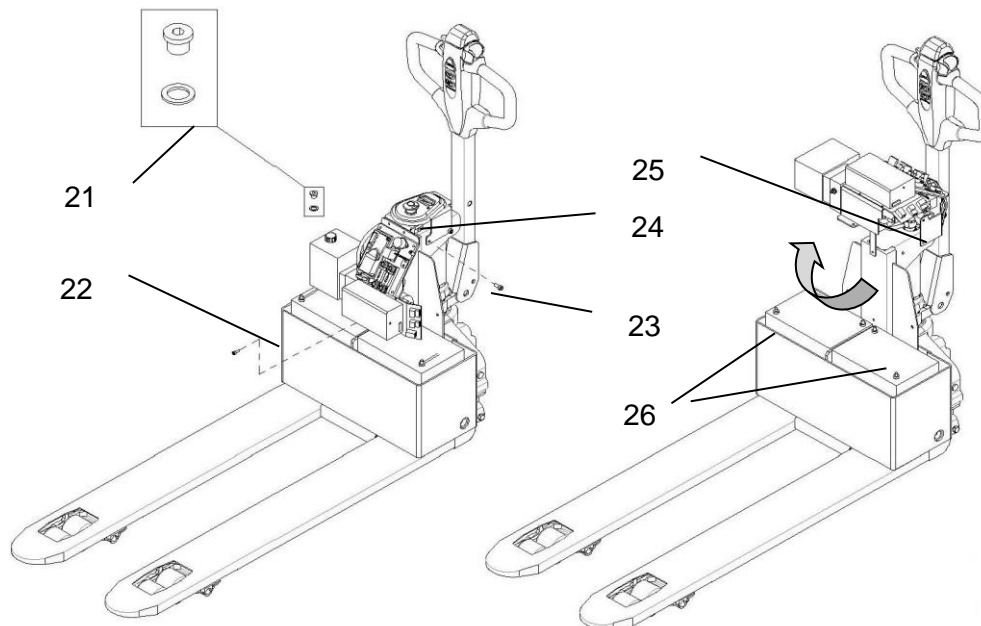
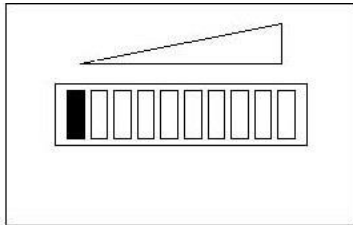

Fig. 15: Preparation to replace the batteries

b. Battery indicator

The discharge status is indicated by ten red LED segments.



Battery discharged

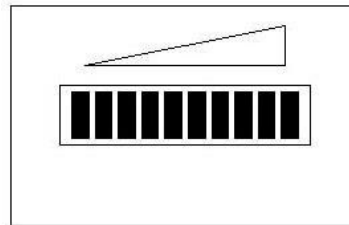

Battery full charged

Fig.16: Battery discharge indicator

- Only when the battery is properly charged, the most right LED lit. As the battery's state-of-charge decreases, successive LEDs light up, only one on at a time.
- The 2nd from left LED flashes, indicating "energy reserve" (70% depth of discharge).
- The 2 most left LEDs alternately flash, indicating "empty" (80% depth of discharge).

c. Charging



- The attached automatic charger is only available for the optional voltage of 110V or 220V as referred.
- The room, where you are charging must be ventilated.
- The exactly charge status can be only checked from the discharge indicator. To control the status, the charging must be interrupted and the truck must be started.

Park the truck at a dedicated secured area with a dedicated power supply. Lower the forks and remove the load. Switch the truck off and connect the main power connector to the power supply. The charger starts charging the battery. Charging is finished until the charging LED (fig.17) produces permanent green light. The charger then goes into a floating mode to prevent the battery against damages. Following table shows the function of the LED-status:

Table 3: LED-Status

| LED- signal | Function |
|-------------|--------------------|
| Red | Battery discharged |

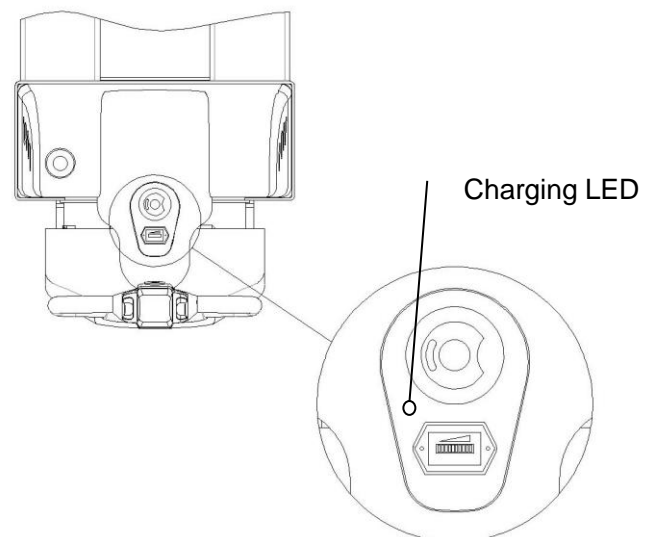

Fig. 17: LED- Status

| | |
|--------|---------------|
| Orange | Charging |
| Green | Fully charged |

When charging is finished, disconnect the connector from the socket and place it in the designated pocket.

8. REGULAR MAINTENANCE



- Only qualified and trained personnel are allowed to do maintenance on this truck.
- Before maintaining, remove the load from the forks and lower the forks to the lowest position.
- If you need to lift the truck, follow chapter 4d by using designated lashing or jacking equipment. Before working, put safety devices (for instance designated lift jacks, wedges or wooden blocks) under the truck to protect against accidental lowering, movement or slipping.
- Please pay attention by maintain the tiller arm. The gas pressure spring is pre-loaded by compression, carelessness can cause injury.
- Use approved and from your dealer released original spare parts.
- Please consider, that oil leakage of hydraulic fluid can cause failures and accidents.
- It is allowed to adjust the pressure valve only from trained service technicians.

If you need to change the wheels, please follow the instructions above. The castors must be round and they should have no abnormal abrasion.

Check the items emphasized maintenance checklist.

a. Maintenance checklist

Table 4: Maintenance checklist

| | | Interval | | |
|-------------------|---|----------|---------|----------|
| | | Monthly | 6 Month | 12 Month |
| Hydraulic | | | | |
| 1 | Check the hydraulic cylinder, piston for damage noise and leakage | • | | • |
| 2 | Check the hydraulic connections and hose for damage an leakage | | | • |
| 3 | Check the hydraulic oil level, refill if necessary | | | • |
| 4 | Refill the hydraulic oil after 1500 working hours | | | • |
| 5 | Check the function of the pressure valve (1500kg +0/+10%) | | | • |
| Mechanical system | | | | |
| 6 | Check the forks for deformation and cracks | | | • |
| 7 | Checks the chassis for deformation and cracks | | | • |
| 8 | Check if all screws are fixed | | | • |
| 9 | Check the push rods for deformation and damages | | | • |
| 10 | Check the gearbox for noise and leakage | | | • |
| 11 | Check the wheels for deformation and damages | | | • |
| 12 | Lubricate the steering bearing | | | • |

| | | | | |
|-------------------|---|---|---|---|
| 12 | Lubricate the pivot points | | • | |
| 14 | Lubricate the grease nipples | • | | |
| Electrical system | | | | |
| 15 | Check the electric wiring for damage | | | • |
| 16 | Check the electric connections | | | • |
| 17 | Test the Emergency switch function | | | • |
| 18 | Check the electric drive motor for noise and damages | | | • |
| 19 | Test the display | | | • |
| 20 | Check the, if correct fuses are used | | | • |
| 21 | Test the warning signal | | | • |
| 22 | Check the contactors | | | • |
| 23 | Check the frame leakage (insulation test) | | | • |
| 24 | Check function and mechanical wear of the accelerator | | | • |
| 25 | Check the electrical system of the drive motor | | | • |
| Battery | | | | |
| 26 | Check the battery voltage | | | • |
| 27 | Check the terminals for corrosion and damage | | | • |
| 28 | Check the battery housing for damages | | | • |
| Charger | | | | |
| 29 | Check the main power cable for damages | | | • |
| 30 | Check the start-up protection during charging | | | • |
| Function | | | | |
| 31 | Check the horn function | | | • |
| 32 | Check the air gap of the electromagnetic brake | | | • |
| 33 | Test the emergency braking | | | • |
| 34 | Test the reverse and regenerative braking | | | • |
| 35 | Test the safety (belly) button function | | | • |
| 36 | Check the steering function | | | • |
| 37 | Check the lifting and lowering function | | | • |
| 38 | Check the tiller arm switch function | | | • |
| General | | | | |
| 39 | Check if all decals are legible and complete | | | • |
| 40 | Carry out a test run | | | • |

b. Lubricating points

Lubricate the marked points according to the maintenance checklist. The required grease specification is: DIN 51825, standard grease.

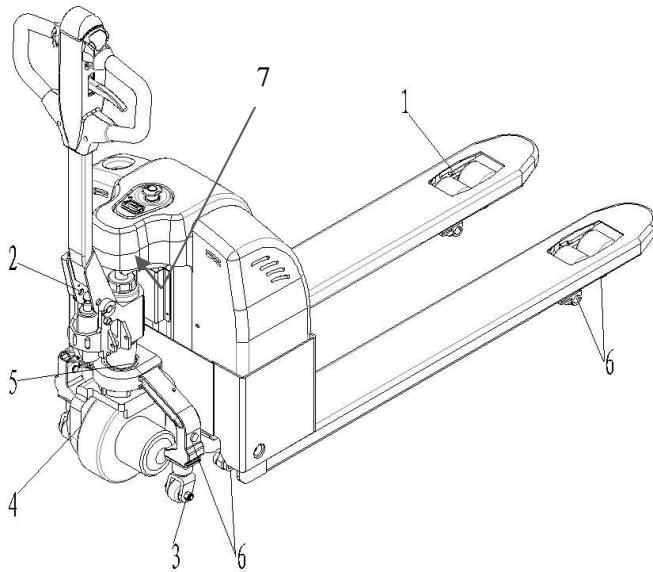

- 1 Load wheel bearings
- 2 Shaft
- 3 Support wheel bearings
- 4 Gear box
- 5 Turning bearing
- 6 Joint
- 7 Cylinder swivel

Fig. 18: Lubricating points

c. Check and refill hydraulic oil

The required hydraulic fluid- type is

- H-LP 46, DIN 51524
- Viscosity is 41.4 - 47
- Depending on the type the amount is ~ 0,7L to 1,0L

Waste material like oil, used batteries or other must be probably disposed and recycled according to the national regulations and if necessary brought to a recycling company.

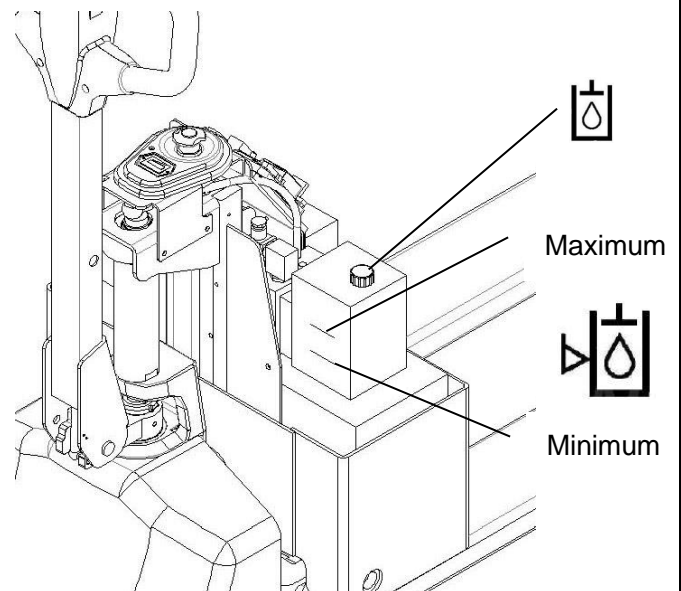

Fig.19: Oil level

EPT 15

Loosen the 2 screws for the main cover and remove the cover.

The minimum and maximum allowed oil level can be checked on the oil tank (Fig. 19).

If necessary add oil at the filling point.

SPT 15

The oil level of the SPT 15 can be checked on the back side of the pump body. For checking, place the truck firstly horizontal and loosen the screw (1) carefully. If oil is leaking out of the hole, the oil level is too high. For refill, put the specified oil into a oilcan with a drain, smaller than the diameter of the screw (1, M10) and pump the oil into the pump, until the oil level has the same height than the hole of the screw. Close the screw with washer and raise and lower the truck several times. Then move the tiller arm with raise position down. By holding the tiller down, lower the forks by moving the operational lever to the 'lower' position. Check the oil level again and if necessary repeat the procedure.

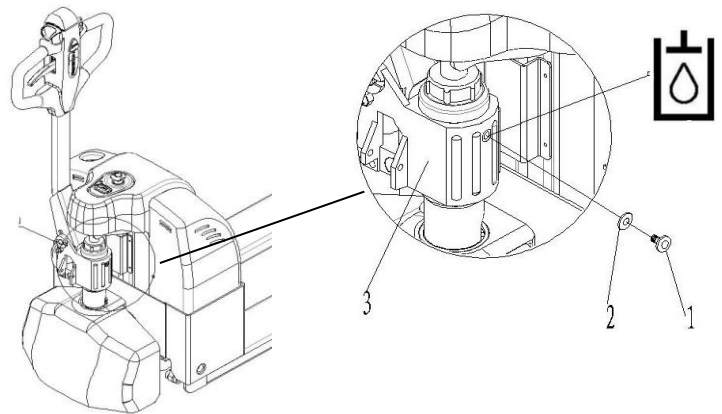

Fig. 20: oil level SPT 15

d. Checking electrical fuses

Remove the main cover. The fuses are located according to fig. 21.

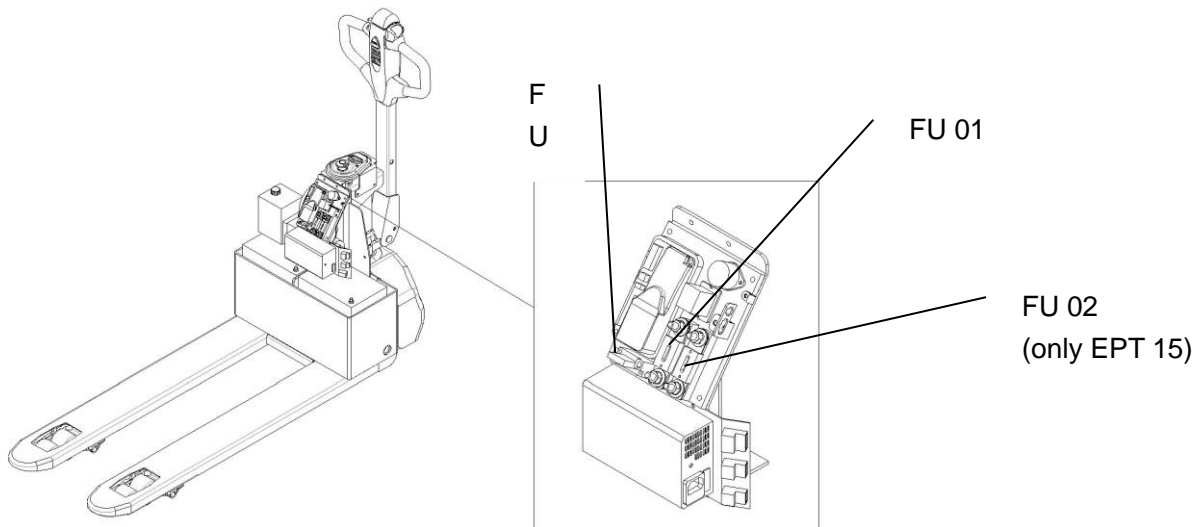

Fig. 21: Location fuses

Table 5: Size fuses

| | Rate |
|-------|-------------------|
| FU | 10A |
| FU 01 | 60A |
| FU 02 | 60A (only EPT 15) |

9. TROUBLE SHOOTING



- If the truck has malfunctions follow the instructions, mentioned under chapter 6.

Table 6: Trouble shooting

| TROUBLE | CAUSE | REPAIR |
|--------------------------------|--|---|
| Load can't be lifted | Load weight too high | Lift only the max. capacity, mentioned on the ID-plate |
| | Battery discharged (EPT 15) | Charge the battery |
| | Lifting fuse faulty | Check and eventually replace the lifting fuse |
| | Hydraulic oil level too low | Check and eventually refill hydraulic oil |
| | Oil leakage | Repair the hoses and/or the sealing of the cylinder |
| Oil leakage from air breathing | Excessive quantity of oil. | Reduce oil quantity. |
| Load can't be lowered | Manual bowden cable unhooked (SPT 15) | Adjust the Bowden cable correctly |
| Truck not starts operating | Battery is charging | Charge the battery completely and then remove the main power plug form the electrical socket. |
| | Battery not connected | Connect the battery correctly |
| | Fuse faulty | Check and eventually replace fuses |
| | Low battery | Charge the battery |
| | Combined emergency switch is activated | De-activate the combined emergency switch by insert and pull the knob. |
| | Tiller in the operating zone | Move the tiller firstly to the braking zone. |

If the truck has malfunctions and can't be operated out of the working zone, jack the truck up and go with a load handler under the truck and safe the truck securely. Then move truck out of the aisle.

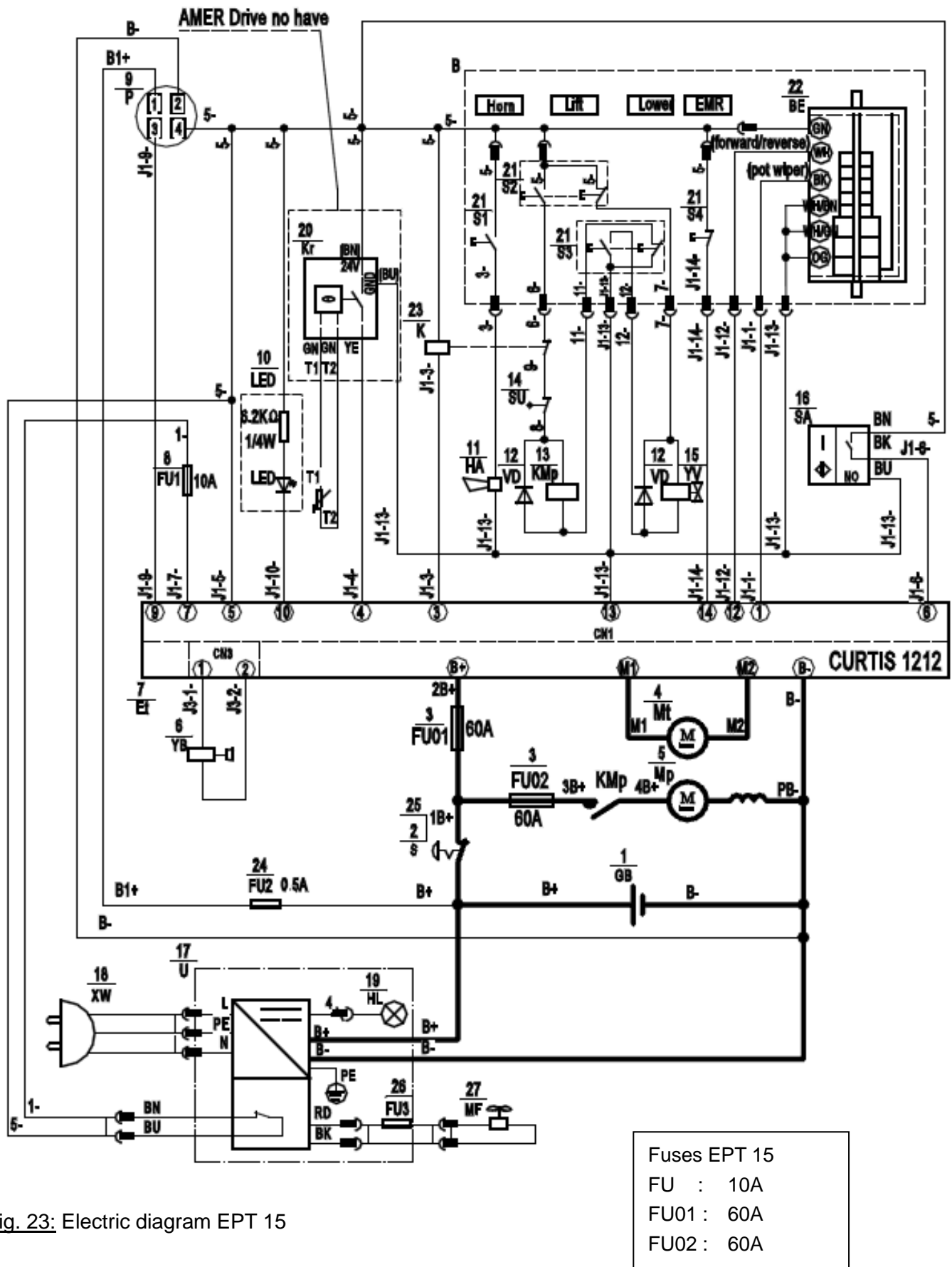

Fig. 23: Electric diagram EPT 15

b. Hydraulic circuit

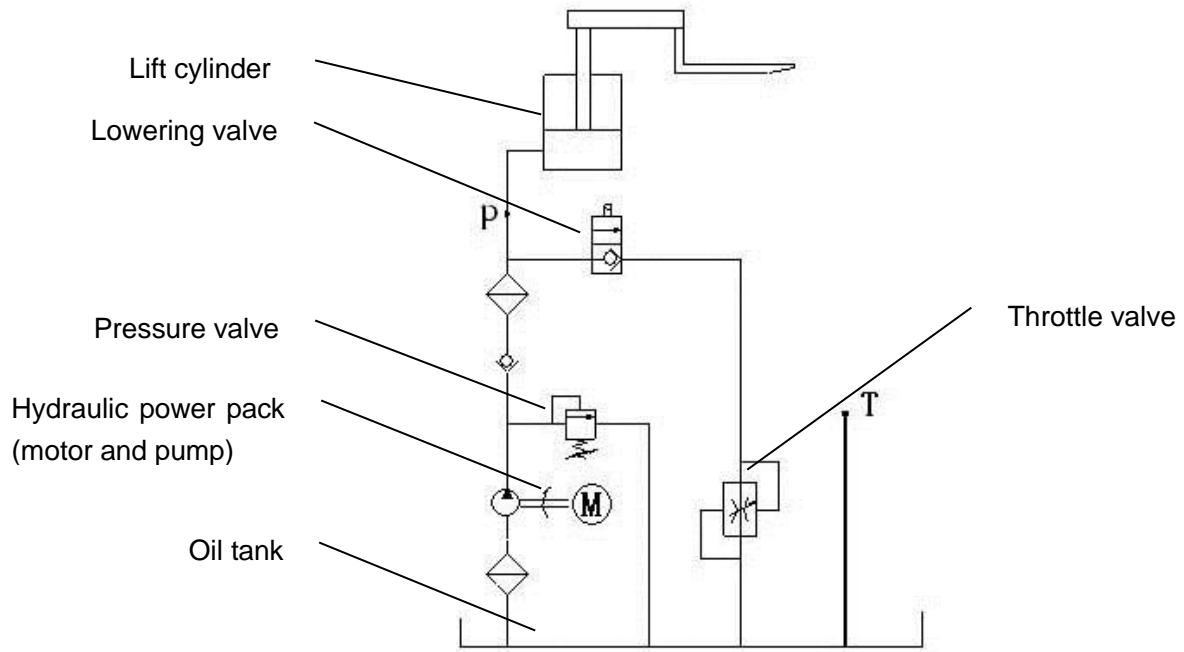

Fig. 24: Hydraulic circuit EPT 15

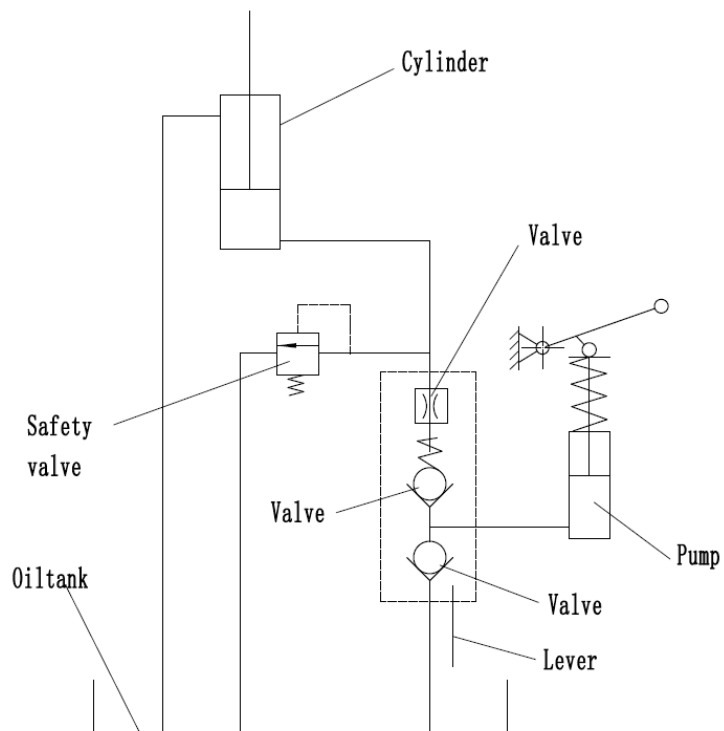

Fig. 25: Hydraulic circuit SPT 15

11. DECLARATION OF CONFORMITY (valid, if sold within the EU)

[GB] CE Declaration of Conformity

The signatory hereby declares that the specified machine conforms to the EU Directive 2006/42/EC (Machine Directive) and 2004/108/EEC (Electro-Magnetic Compatibility, EMC) including their amendments as translated into national legislation of the member countries. The signatory is individually authorized to compile the technical documents.

[D] EG-KONFORMITÄT SERKLÄRUNG

Der Unterzeichner bescheinigt hiermit, dass die im Einzelnen bezeichnete Maschine den Europäischen Richtlinien 2006/42/EG (Maschinenrichtlinie) und 2004/108/EG (Elektromagnetische Verträglichkeit - EMV) einschließlich deren Änderungen sowie dem entsprechenden Rechtsersatz zur Umsetzung der Richtlinien in nationales Recht entspricht. Der Unterzeichner ist bevollmächtigt, die technischen Unterlagen zusammenzustellen.

[E] DECLARACIÓN DE CONFORMIDAD CE

El signatario certifica por medio de la presente que la máquina especificada cumple con las Normas Europeas 2006/42/CE (Normativa para maquinarias) y 2004/108/CE (Compatibilidad electromagnética), incluyendo sus respectivas modificaciones, así como con el decreto-ley para la adaptación de las normas al derecho nacional. El signatario dispone de una autorización individual que le permite compilar la documentación técnica.

[F] DECLARATION DE CONFORMITE CE

Par la présente déclaration, les soussignés certifient que le machines spécifiée ci-dessus est conforme à la loi et aux directives européennes 2006/42/CE (directive sur les machines) et 2004/108/CEE (compatibilité électromagnétique - CEM), y compris aux modifications qui y sont apportées et à l'arrêté autorisant sa transposition en droit national. Chaque signataire est habilité à établir individuellement la documentation technique.

[NL] EG-CONFORMITEITSVERKLARING

Ondergetekenden verklaren hierbij dat - volgens de nationale wetgeving van de Lidstaten - de hierboven vermelde opgegeven machina beantwoordt aan de bepalingen qua veiligheid bij machines (EG richtlijn 2006/42/EC) en electro-magnetische compatibiliteit (EG richtlijn 2004/108/EEC).

Ondergetekenden zijn ieder individueel gemachtigd het technisch dossier samen te stellen.

[P] DECLARAÇÃO DE CONFORMIDADE CE

Pela presente, os signatários certificam que o máquina especificado está conforme às Directivas Europeias 2006/42/CE („Máquinas“) e 2004/108/CEE („Inocuidade Electromagnética - IEM“), incluindo as alterações das mesmas e o respectivo decreto-lei para a transposição em lei nacional. Cada um dos signatários está autorizado a proceder à elaboração da documentação técnica.

[I] DICHIARAZIONE DI CONFORMITÀ CE

I sottoscritti dichiarano che il veicolo per trasporti interni a macchina specificato soddisfa le Direttive Europee 2006/42/EC (Direttiva Macchine) e 2004/108/EEC (Compatibilità elettromagnetica - EMV) comprese le relative modifiche, come pure il rispettivo decreto legislativo per la conversione delle direttive in diritto nazionale. I sottoscritti sono singolarmente autorizzati alla creazione della documentazione tecnica.

[BG] ЕВРОПЕЙСКА ОБЩНОСТ - ДЕКЛАРАЦИЯ ЗА СЪОТВЕТСТВИЕ

Подписаните удостоверяват с настоящето, че подробно описаното машина средство отговаря на европейския норматив 2006/42/EG (норматив за машини) и на 2004/108/EG (електро-магнетична съвместимост), включително с техните промени, както и на съответния указ за прилагане на нормативите в националното право. Подписаните при това са упълномощени поотделно да съставят техническата документация.

[CZ] EG - PROHLÁŠENÍ O SHODĚ

Níže podepsaný tímto potvrzuje, že podrobný popis uvedené stroje odpovídá Evropským směrnícím 2006/42/EC (směrnice pro stroje) a 2004/108/EEC (elektromagnetická interference - EMV) včetně jejich pozdějších úprav, jakož i příslušným právním výnosům pro uplatnění příslušné směrnice v rámci národního práva. Každý z podepsaných jsou jednotlivě způsobilí k vytvoření technických podkladů.

[DK] EF-OVERENSSTEMMELSE SERKLÆRING

Undertegnede attesterer hermed, at det specificerede maskine stemmer overens med de Europæiske Direktiver 2006/42/EU (maskindirektiv) og 2004/108/EØF (elektromagnetisk kompatibilitet - EMC) samt med den modsvarende lovgivning til implementering af direktiver i den nationale lovgivning. De undertegnede er hver for sig beføjede til at sammenstille de tekniske dokumenter.

[EST] EL vastavusavaldus

Allakirjutatud tõendavad käesoleval, et üksikasjaliselt kirjeldatud täpsustatud masin vastab Euroopa direktiividele 2006/42/EÜ (Direktiiv masinate kohta) ja 2004/108/EMÜ (Elektromagnetiline sobivus - EMS) kaasa arvatud nende muudatud ja nende vastavatele õigusmäärustele direktiivide muutmiseks siseriiklikuks õiguseks. Iga allakirjutatu üksikult on volitatud koostama tehnilist dokumentatsiooni.

[FIN] EU-YHDENMUKAISUUSSELÖSTUS

Allekirjoittaneet todistavat täten, että kukin erikseen mainittu omalla voimantilanteellä varustettu tehdaskone vastaa EU-direktiivien 2006/42/EC (koneenrakennusdirektiivi) ja 2004/108/EEC (sähkömagneettinen yhteensopivuus – EMC) määräyksiä sekä niiden muutoksia ja niiden kansalliseen lainsäädäntöön soveltamista koskevaa oikeussäätöä. Jokaisella allekirjoittaneista on oikeus itsenäisesti laatia asiaankuuluvia teknisiä asiakirjoja.

[GR] ΔΗΛΩΣΗ ΣΥΜΜΟΡΦΩΣΗΣ ΕΟΚ

Οι υπογράφωντες βεβαιώνουν διά της παρούσης ότι το συγκεκριμένο μηχάνημα συμμορφώνεται προς την Κοινοτική Οδηγία 2006/42/ΕΚ («Μηχανήματα») και 2004/108/ΕΟΚ (Ηλεκτρομαγνητικής Συμβατότητας, ΗΜΣ), καθώς και οι τροποποιήσεις τους, όπως μεταφράστηκε στην εθνική νομοθεσία των χωρών μελών. Οι υπογράφωντες είναι σε κάθε περίπτωση εξουσιοδοτημένοι ατομικά να καταρτίσουν τα τεχνικά έγγραφα.

[H] EU KONFORMITÁSI NYILATKOZAT

Alulírottak ezennel igazolják, hogy a részletesen leírt a megadott gép megfelel a 2006/42/EC (Gép-Irányelv) és a 2004/108/EEC (Elektromágneses összeférhetőség - EMV) Európai Irányelveknek, beleértve azok módosításait, valamint az irányelvek nemzeti jogba történő átültetésére irányuló megfelelő jogi rendelkezést. Továbbá az alulírottak mindegyike rendelkezik meghatalmazással arra nézve, hogy összeállíthatja a műszaki dokumentációt.

[LT] ES atitikimø deklaracija

Žemiau pasirašę asmenys patvirtina, kad atskirai aprašytas nurodyta mašina atitinka Europos Sąjungos direktyvas 2006/42/EB (Mašinų direktyva) ir 2004/108/EEB (Elektromagnetinis suderinamumas – EMS) įskaitant jų pakeitimus, o taip pat ir atitinkamą teisės aktą dėl direktyvų įgyvendinimo nacionalinėje teisėje. Kiekvienas iš pasirašiusių asmenų turi teisę ruošti techninę dokumentaciją.

[LV] ES atbilstības deklarācija

Ar zemāk redzamajiem parakstiem tiek apliecināts, ka norādīts mašina atbilst Eiropas Savienības normatīvam 2006/42/EG (Mašīnu normatīvas) un 2004/108/EWG (Elektromagnētiskā atbilstība – EMV), ieskaitot to izmaiņas, kā arī atbilstošos tiesiskos rīkojumus normatīvu pielāgošanai nacionālajai likumdošanai. Parakstu īpašnieki ir atsevišķi pilnvaroti sastādīt tehniskās dokumentācijas.

[N] EU-KONFORMITETSERKLÆRING

Undertegnede bekræfter hermed at de enkelte betegnede maskin med kraftdrift tilsvarende de europæiske retningslinjerne 2006/42/EC (maskinretningslinje)

og 2004/108/EEC (elektromagnetisk fordraglighed - EMV) inklusiv disses endringer og den tilsvarende rettsforordning til omsetning av nasjonal rett. Hver undertegnede er fullmektig til å sette sammen de tekniske dokumentene.

[PL] DEKLARACJA ZGODNOŚCI Z NORMAMI UE

Niżej podpisani potwierdzają niniejszym, że opisany tutaj, napędzany określona maszyna spełnia wymagania określone w dyrektywach Europejskich 2006/42/EC (Maszyny) i 2004/108/EEC (Nieszkodliwość elektromagnetyczna - EMC) wraz z ich późniejszymi zmianami oraz odpowiednimi rozporządzeniami mającymi na celu przekształcenie tych dyrektyw w prawo krajów członkowskich. Niżej podpisani są pojedynczo upoważnieni do zestawiania dokumentacji technicznej.

[RO] DECLARAȚIE DE CONFORMITATE CE

Subsemnații adevăresc prin prezenta că vehiculul de specificat mașină descris individual corespunde directivelor europene 2006/42/CE (Directiva privind mașinile) și 2004/108/CEE (Compatibilitatea electromagnetică - CEM) inclusiv modificărilor lor precum și actului legislativ corespunzător pentru transpunerea directivelor în drept național. Subsemnații sunt fiecare în parte împuterniciți să întocmească documentația tehnică.

[RUS] Декларация соответствия стандартам ЕС

Настоящим лица, подписавшие документ, удостоверяют, что машина с указанной спецификацией соответствует европейским стандартам 2006/42/EG (Транспортная директива) и 2004/108/ЕWG (Электромагнитная совместимость - EMC), включая изменения в них, а также соответствующим национальным стандартам и нормам. Каждое по отдельности лицо, подписавшее документ, имеет полномочия для составления технической документации.

[S] EG-KONFORMITETS FÖRKLARING

Undertecknarna intygar härmed att det i detalj betecknade maskin uppfyller de Europeiska direktiven 2006/42/EG (Maskindirektiv) och 2004/108/EEG (Elektromagnetisk tålighet - EMV), inklusive ändringarna i detta och den motsvarande rättsförordningen för att omsätta direktiven i nationell rätt. Undertecknarna har var för sig fullmakt att sammanställa den tekniska dokumentationen.

[SK] vyhlásenie o zhode

Dolu podpísaní týmto potvrdzujeme, že podrobný popis uvedené stroje zodpovedá Európskym smerniciam 2006/42/EC (ernica pre stroje) a 2004/108/EWG (elektromagnetická tolerancia – EMV) vrátane jeho neskorších úprav, rovnako zodpovedá aj príslušným právnym nariadeniam na uplatnenie smerníc v rámci národného práva. Každý z podpísaných je jednotlivo splnomocnený na vytvorenie technických podkladov.

[SLO] EU IZJAVA O SKLADNOSTI

Podpisani s tem potrjujemo, da posamično označeno določeno stroj vozilo odgovarja Evropski direktivi 2006/42/EC (Direktiva o strojih) in 2004/108/EEC (Elektromagnetna skladnost - EMV) vključno z njihovimi spremembami ter ustrezno pravno uredbo o prevzemu smernic v nacionalno pravo. Podpisniki so vsakokrat posamezno pooblaščenji za izdajanje tehnične dokumentacije.

[TR] AB Uygunluk Açıklaması

İmza sahibi şahıslar, ayrıntıları belirtilen makine aracının, 2006/42/EC (Makine Yönergesi) ve 2004/108/EEC (Elektromanyetik Uyumluluk – EMC) no'lu Avrupa Yönergelerine ve bunların değişiklik sonucu oluşan metinlerine ve yönergelerin milli hukuk hükümlerine dönüştürülmesine dair ilgili hukuk karamamesine uygun olduğunu tasdik ederler. İmza sahibi şahıslar teknik dosyaları bir araya getirmek için münferiden vekil tayin edildi.

- (1) Type/ Typ/ Tipo/ Modello/ Тууппи/ Tipo / ΤΥΠΟΣ/ Tipus/ Tip/ Тип/ Tips/ Tipas/ Tüüp:
- (2) Serial No./ Serien-Nr./ N°. de série/ Seriennummer/ N° de serie/ Numero di serie/ Serienr./ Sarjanro/ αυξάνων αριθμός/ Serioné číslo/ Szériaszám/ Nr.Seryjny/ Serijska številka/ Výrobné číslo/ Серийный номер/ Seri No./ Seerianr./ Sērijas Nr./ Serijos numeris:
- (3) Year of constr./ Baujahr/ Année de constr./ Bouwjaar/ Año de constr./ Anno di costruzione/ Produktionsår/ Byggeår/ Tillverkningsår/ Valmistusvuosi / Ano de fabrico / έτος κατασκευής/ Rok výroby/ Gyártási év/ Rokprodukcji / Letnik / Год изготовления / Üretim yılı / Vájalaskeasta / Izgatavošanas gads / Gamybosmetai
- (4) Manufacturer or his authorized representative in Community/ Hersteller oder in der Gemeinschaft ansässiger Vertreter/ Fabricant ou son mandataire établi dans la Communauté/ Fabrikant of zijn in de Gemeenschap gevestigde gemachtigde/ Fabricante o representante establecido en la Comunidad/ Construtor ou Representante estabelecido na Comunidade/ Costruttore oppure il suo rappresentante nella Comunità/ Fabrikant eller dennesi Fællesskabet etablerede befuldmægtigede/ Produsent eller agent innen felleskapet/ Tillverkare eller representant inom EU/ Valmistaja tai yhteisömaassa oleva edustaja / V'robce nebo jeho zastoupení/ Gyártó / producent albo jego przedstawiciel w EG (Wspólnota Europejska)/ Κατασκευαστής ή όκνηνο ηνπηθώλ αληπηζνζώπσλ/ Üretici ya da Bölgedeki Yetkili Temsilci/ Proizvajalec ali pooblaščenji zastopnik s sedežem v EU/ Výrobca alebo zástupca so stálym bydliskom v EÚ / Изготовитель или его представитель, зарегистрированный в стране Содружества/ Tootja või organisatsioonis paiknev esindaja/ Ražotājs vai vietējais uzņēmuma pārstāvis / Gamintojas arba šalyje reziduojantis atstovas:
- (5) Date/ Datum/ Data/ Fecha/ datum/ Dato/ päiväys/ Kuupäev/ Datums/дата / Dátum/ dátum/ tarih/ ημερομηνία
- (6) Authorised signatory/ Im Auftrag/ pour ordre/ Incaricato/ Por orden de/ por procuração/ op last van/ på vegne af/ på uppdrag/ Etter oppdrag/ psta./ Ülesandel / pavedus / v.i. / По поручению / megbízásából /длжносно лице / z pověření / z poverenia / po nalogu / na polecenie / din sarcina / adina / θαη' εληνηή

If you can read this text:

- Your truck might be sold outside the EU; this declaration is then not valid.
- Your present version is a (printed) e-document
- The declaration is not complete.
In this case please ask for a copy