

# INSTRUCTION HANDBOOK

## Electric Tow Tractor

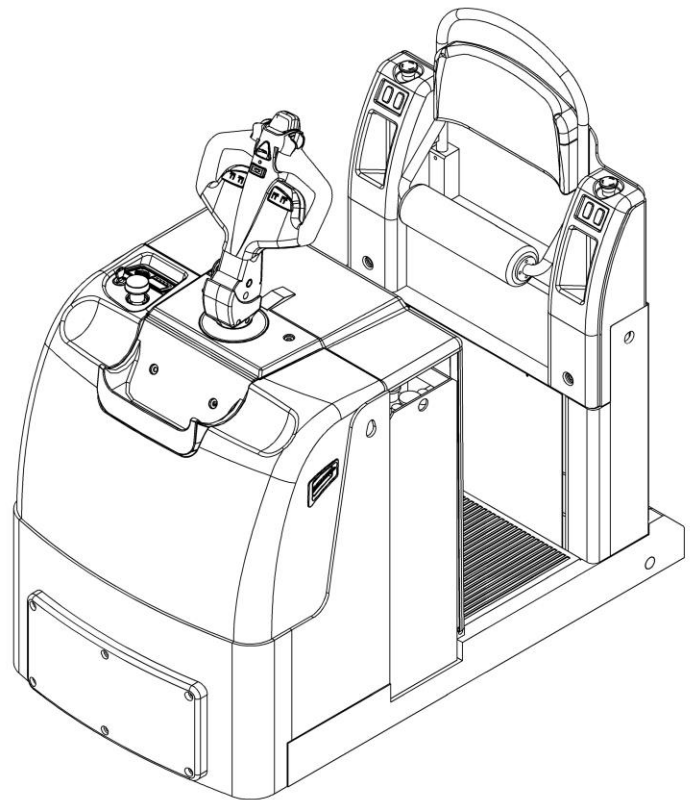

### **WARNING**

Do not use the tow tractor before reading and understanding these operating instructions.

### **NOTE:**

- Please check the designation of your present type at the last page of this document as well as on the ID-plate.
- Keep for future reference.

Version 09/2014

T 30-SMS-001-EN

## FOREWORD

Before operating the tractor, read this ORIGINAL INSTRUCTION HANDBOOK carefully and understand the usage of the tractor completely. Improper operation could create danger.

This handbook describes the usage of different tow tractor. When operating and servicing the tractor, make sure, that it applies to your type.



**Chapter 11 describes specialized stipulations and regulations for the American market. Follow these instructions and stipulations if you operate the tractor within the American market!**

Keep this handbook for future reference. If this or the warning/ caution labels are damaged or got lost, please contact your local dealer for replacement.

This tractor complies with the requirements according to EN 3691-1; -5 (Industrial trucks- safety requirements and verification, part 1; part 5), EN 12895 (Industrial trucks- electromagnetic compatibility), EN 12053 (Safety of industrial trucks- test methods for measuring noise emissions), EN 1175 (Industrial trucks safety – electrical requirements), assumed the tractor is used according to the described purpose. The noise level for this machine is < 69 dB(A) according to EN 12053.

### ATTENTION:

- Environmentally hazardous waste, such as batteries, oil and electronics, will have a negative effect on the environment, or health, if handled incorrectly.
- The waste packages should be sorted and put into solid dustbins according to the materials and be collected disposal by local special environment protection bureau. To avoid pollution, it's forbidden to throw away the wastes randomly.
- To avoid leaking during the use of the products, the user should prepare some absorbable materials (scraps of wooden or dry duster cloth) to absorb the leaking oil in time. To avoid second pollution to the environment, the used absorbable materials should be handed into special departments in terms of local authorities.
- Our products are subject to ongoing developments. Because this handbook is only for the purpose of operating /servicing the tow tractor, therefore please have understanding, that there is no guarantee out of particular features out of this handbook.



**NOTE: On this manual, the left sign means warning and danger, which can lead to death or serious injury if not followed.**

### Copyright

The copyright remains with the company, mentioned on the CE- certificate at the end of this document or, if sold within the USA, with the company, mentioned on the company sticker.

# TABLE OF CONTENTS

1. CORRECT APPLICATION .....	3
2. DESCRIPTION OF THE PALLET TRACTOR .....	4
a. Overview of the main components .....	4
b. Main technical data .....	5
c. Description of the safety devices and warning labels (Europe and other, excepting USA) .....	6
d. Identification plate .....	7
3. WARNINGS, RESIDUAL RISK AND SAFETY INSTRUCTIONS .....	7
4. COMMISSIONING, TRANSPORTING, DECOMMISSIONING .....	8
a. Commissioning .....	8
b. Transportation .....	8
c. Decommissioning .....	9
5. DAILY INSPECTION .....	9
6. OPERATING INSTRUCTIONS .....	9
a. Parking .....	10
b. Travelling .....	10
c. Steering .....	10
d. Braking .....	10
e. Malfunctions .....	11
f. Emergency .....	11
7. BATTERY CHARGING AND REPLACEMENT .....	11
a. Replacement .....	12
b. Battery indicator .....	12
c. Charging .....	13
8. REGULAR MAINTENANCE .....	13
a. Maintenance checklist .....	13
b. Lubricating points .....	15
c. Checking electrical fuses .....	15
9. TROUBLE SHOOTING .....	16
10. WIRING/ CIRCUIT DIAGRAM .....	17
a. Electrical circuit diagram .....	17
11. SPECIALIZED STIPULATIONS FOR THE US- AMERICAN MARKET .....	18
a. Foreword/ Compliance .....	18
b. Description warning labels (only US- market) .....	19
c. Technical data for US market .....	21
12. DECLARATION OF CONFORMITY (valid, if sold within the EU) .....	22

# 1. CORRECT APPLICATION

It is only allowed to use this tractor according to this instruction handbook.

A wrong usage can cause human injuries or can damage equipment.

The operator/ the operating company has to ensure the correct usage and has to ensure, that this tractor is used only by staff, which is trained and authorized to use this tractor.

The tractor has to be used on substantially firm, smooth, prepared, level and adequate surfaces. The tractor is intended to be used for indoor applications with ambient temperatures between +5°C and +40°C and for light duty applications without crossing permanent obstacles or potholes. Operating on ramps is not allowed. While operating, the load must be placed approximately on the longitudinal centre plane of the tractor.

Lifting or transporting people is forbidden.

The capacity is marked on capacity sticker as well on the Identification plate. The operator has to consider the warnings and safety instructions.

Operating lighting must be minimum 50 Lux.

## Modification

No modifications or alterations to this tractor which may affect, for example, capacity, stability or safety requirements of the tractor, shall be made without the prior written approval of the original tractor manufacturer, its authorized representative, or a successor thereof. This includes changes affecting, for example braking, steering, visibility and the addition of removable attachments. When the manufacturer or its successor approve a modification or alteration, they shall also make and approve appropriate changes to capacity plate, decals, tags and operation and maintenance handbooks.

By not observing these instructions, the warranty becomes void.

## 2. DESCRIPTION OF THE PALLET TRACTOR

### a. Overview of the main components

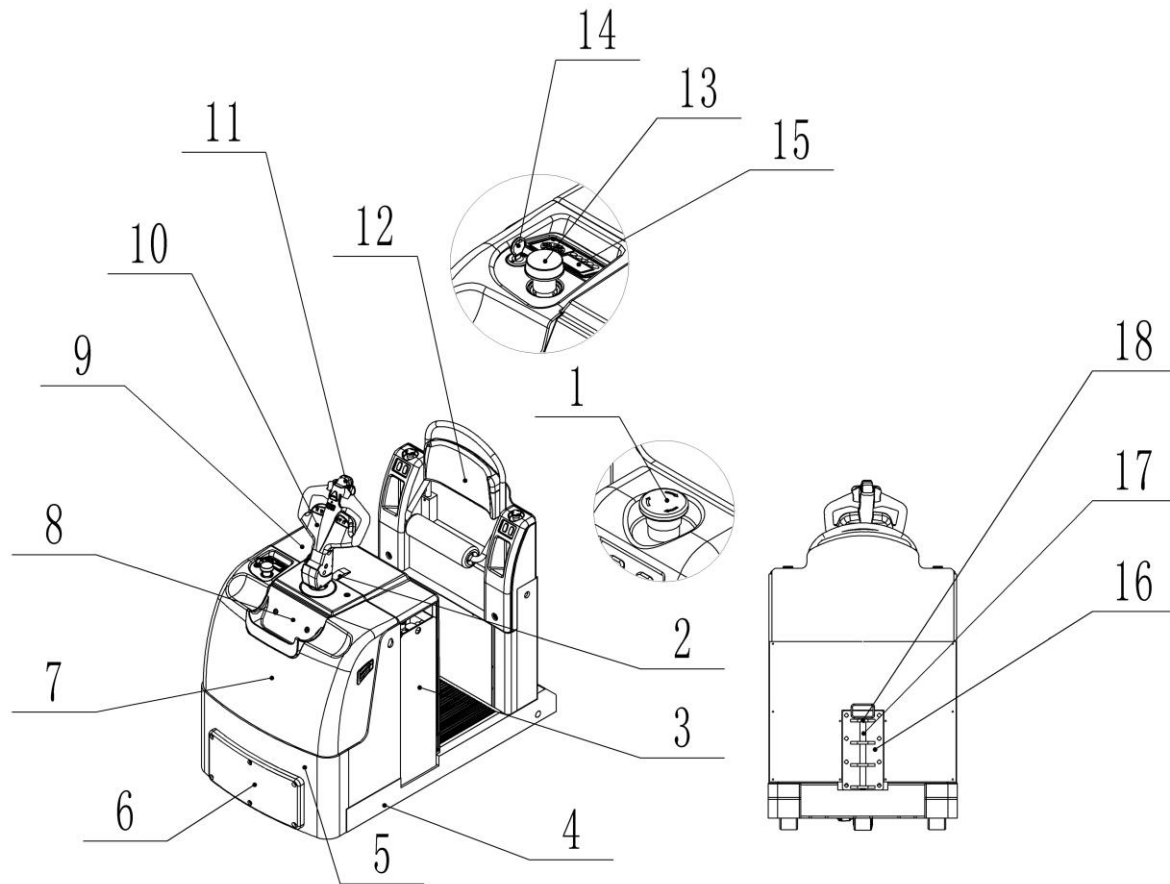

Fig. 1: Overview main components

- |                     |                                |
|---------------------|--------------------------------|
| 1. Emergency button | 11. Safety stop (belly) button |
| 2. Battery clamp    | 12. Backrest                   |
| 3. Battery          | 13. Emergency button           |
| 4. Chassis          | 14. Key switch                 |
| 5. Apron            | 15. Indicator                  |
| 6. Crash pad        | 16. Traction frame             |
| 7. Main cover       | 17. Pull rod                   |
| 8. Storage cover    | 18. Draw cord                  |
| 9. Battery cover    |                                |
| 10. Tiller          |                                |

## b. Main technical data

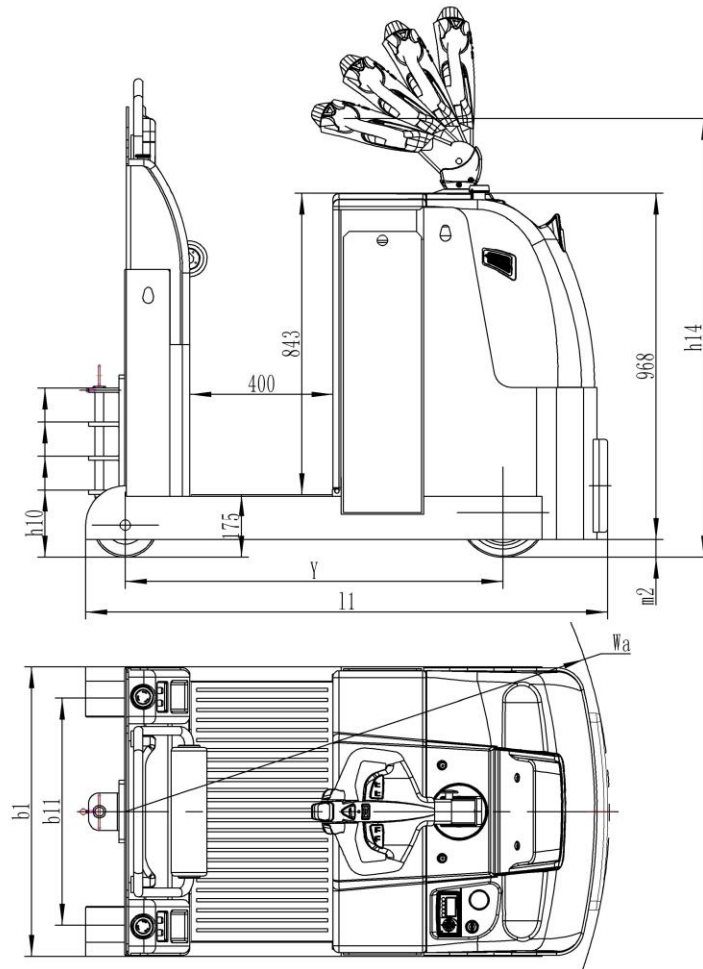

Fig. 2: Technical data

Table 1: Main technical data for standard version

Type sheet for industrial tractor acc. to VDI 2198				
Distinguishing mark	1.2	Manufacturer's type designation		T 30
	1.3	Power (battery ,diesel,petrol gas,manual)		Battery
	1.4	Operator type		Pedestrian
	1.5	Load Capacity / rated load	Q(t)	3.0
	1.7	Rated drawbar pull	F(N)	800
	1.9	Wheelbase	Y(mm)	1051.5
Weight	2.1	Service weight	kg	920
	2.3	Axle loading, unladen front/rear	kg	560/360
Wheel chassis	3.1	Tires		R+PU
	3.2	Tire size, front	Ø x w (mm)	Ø250X82
	3.3	Tire size, rear	Ø x w (mm)	Ø180X76
	3.5	Wheels, number front/rear(x=driven wheels)		1+1X2
	3.6	Tread, front	b <sub>10</sub> (mm)	----
	3.7	Tread, rear	b <sub>11</sub> (mm)	635
Dimensions	4.9	Height of tiller in drive position min./ max.	h <sub>14</sub> (mm)	1450/ 1420/1340/1226
	4.12	Overall length	h <sub>10</sub> (mm)	188/283/378/473

	4.19	Overall width	l <sub>1</sub> (mm)	1453
	4.21	Overall width	b <sub>1</sub> (mm)	810
	4.32	Ground clearance, centre of wheelbase	m <sub>2</sub> (mm)	50
	4.35	Turning radius	Wa (mm)	1348
Performance data	5.1	Travel speed, laden/ unladen	km/h	7.0/7.5
	5.5	Drawbar pull, laden/unladen	N	800/--
	5.6	Max. drawbar pull, laden/unladen	N	2800/--
	5.10	Service brake		Electromagnetic
E- Motor	6.1	Drive motor rating S2 60min	kW	2.9
	6.3	Battery acc. to DIN 43531/ 35/ 36 A, B, C, no		No, 3PZS
	6.4	Battery voltage, nominal capacity K5	V/Ah	24/465
	6.5	Battery weight	kg	377
Additional data	8.1	Type of drive control		AC- speed control
	8.4	sound level at driver`s ear acc. to EN 12053	dB(A)	70

### c. Description of the safety devices and warning labels (Europe and other, excepting USA)



For the USA –market, the description of the safety and warning labels is mentioned in chapter 11.

- A Identification plate (ID-plate)
- B Sticker to read and follow these Instructions Crane hook label
- C Crane hook label

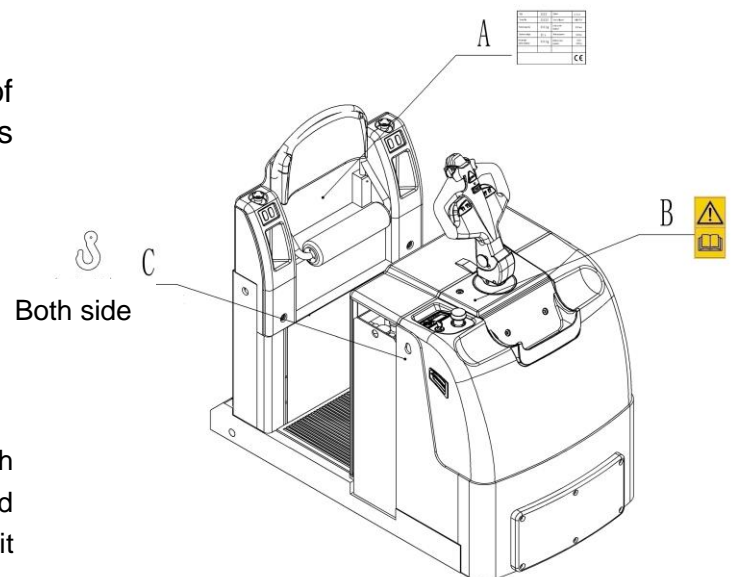

**Fig. 3:** Safety and warning labels

The tractor is equipped with an emergency switch (1) or (13) which stops driving- functions and engages the failsafe electromagnetic brake when it is pushed.

By turning the pushed button 90° anti-clockwise, the push- button can be removed and then prevent against unauthorized access. Remove this button, if you not operate the tractor. The tractor is equipped with a safety (belly) button (11) which switches the driving function away from the operator, if the tractor travels towards the operator and the tiller is activated in the tillers operating position. Follow also the instructions given on the decals. Replace the decals if they are damaged or missing.

## d. Identification plate

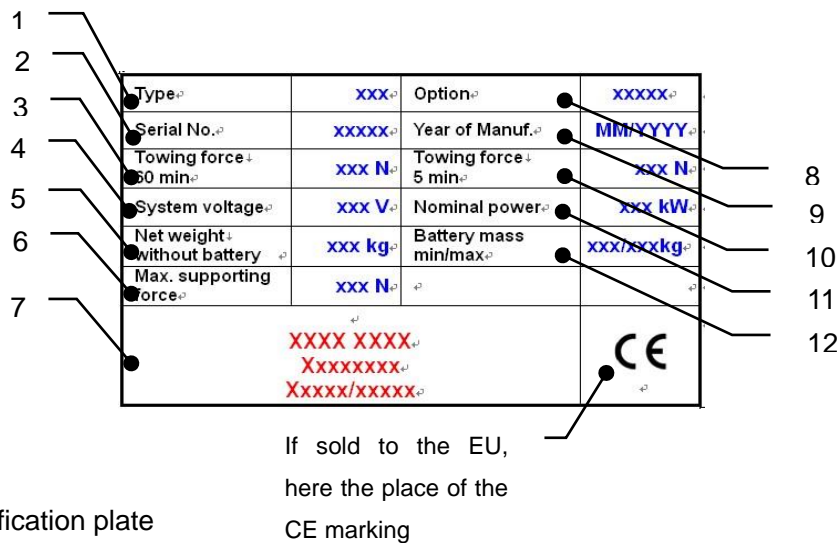

Fig. 4: Identification plate

- |   |  |    |                                    |
|---|--|----|------------------------------------|
| 1 | Designation, type                            | 7  | Name and address of manufacturer   |
| 2 | Serial number                                | 8  | Option                             |
| 3 | Towing force S2 60 min.                      | 9  | Year of manufacture                |
| 4 | Supply voltage in V                          | 10 | Towing force S2 5 min.             |
| 5 | Own mass (self weight) in kg without battery | 11 | Nominal power S2 60 min. in kW     |
| 6 | Maximum supporting force                     | 12 | Minimum and maximum battery weight |

## 3. WARNINGS, RESIDUAL RISK AND SAFETY INSTRUCTIONS



### **DO NOT**

- Allow other person than the operator to stand in front of or behind the tractor when it is moving.
- Overload the tractor.
- Put foot in front of the wheels, injury could result.
- Lift people. People could fall down and suffer severe injury.
- Push or pull loads
- Use this tractor on ramps
- Use the tractor with unstable, unbalanced not stable load.
- Use tractor without manufacturer's written consent.
- Lifted loads could become unstable at wind forces. In the case of wind forces do not lift the load if there is any influence to the stability.

Watch difference in floor levels when driving. Load could fall down or the tractor could get uncontrollable. Keep watching the condition of load. Stop operating the tractor if load becomes unstable.

Brake the tractor and activate the emergency switch(1) or (13) by pushing when sliding load on or off the tractor. If the tractor has any malfunctions, follow chapter 6.

Practice maintenance work according to regular inspection. This tractor is not designed to be water resistant. Use the tractor under dry condition. Prolonged continuous operation might cause damage of the power pack.



- When operating the tow tractor, the operator has to wear safety shoes.
- The tractor is intended to be used for indoor applications with ambient temperatures between +5°C and + 40°C.
- The operating lighting must be minimum 50 Lux.
- It is not allowed to use the tractor on ramps.
- To prevent unintended sudden movements when not operating the tuck (i.e. from another person, etc.) switch of f the tractor when not operating it.

## 4. COMMISSIONING, TRANSPORTING, DECOMMISSIONING

### a. Commissioning

Table 2: Commissioning data

Type	T 30
Commissioning weight [kg]	app. 970 kg
Dimensions [mm]	1453X810X1446

After receiving our new tow tractor or for re-commissioning you have to do following before (firstly) operating the tractor:

- Check if are all parts included and not damaged
- Eventually installation and charging the batteries (follow chapter 7)
- Do the work according to the daily inspections as well as functional checks

### b. Transportation

For transporting, remove the trailer, fix the tractor safely with dedicated lifting gear according to the following figures.



**DURING TRANSPORTATION ON A LORRY OR TRACTOR ALWAYS FASTEN THE TRACTOR SECURELY**

Park the tractor securely. Fasten the tractor according to fig. 5 by slinging dedicated lashing belts around both sides of the tractors and fasten the other side at the transporting tractor.

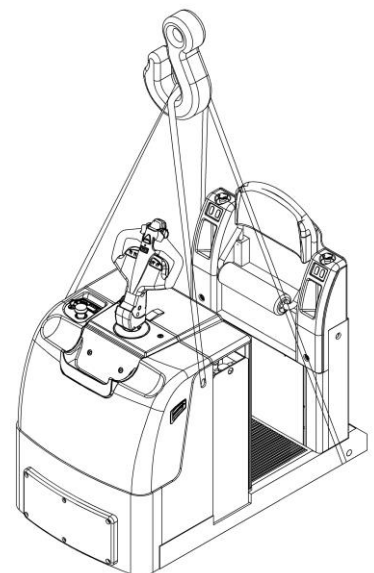

**Fig. 5:** Lifting with a crane

## C. Decommissioning

For storage, remove the trailer, grease all in this handbook mentioned greasing points (regular inspection), eventually protect the tractor against corrosion and dust. Remove the batteries and jack the tractor safely, so that there will be no flattening after storage.

For final decommissioning hand the tractor to a designated recycling company. Oil, batteries and electric components must be recycled due to legal regulations.

## 5. DAILY INSPECTION

This chapter describes pre-shift checks before putting the tractor into operation.

Daily inspection is effective to find the malfunction or fault on this tractor. Check the tractor on the following points before operation.

Remove load from the tractor.

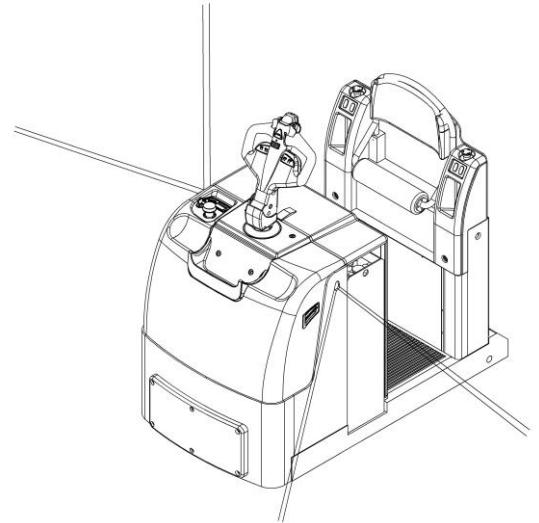

Fig. 6: fixing points



**DO NOT USE THE TRACTOR IF ANY MALFUNCTION IS FOUND.**

- Check for scratches, deformation or cracks.
- Check the vertical creep of the tractor.
- Check the smooth movement of the wheels.
- Check the function of the emergency brake by activating the combined emergency button.
- Check, the tiller arm- switch braking function
- Check if all bolts and nuts are tightened firmly.
- Visual check if there are any broken hoses or broken electric wires.

## 6. OPERATING INSTRUCTIONS



**BEFORE OPERATING THIS TRACTOR, PLEASE FOLLOW THE WARNINGS AND SAFETY INSTRUCTIONS (CHAPTER 3). AND CONSIDER THE OPERATING OF THE SPECIFIC HOOK SYSTEM.**

Make sure, that the load is stable and that the daily inspection of the tow tractor as well as the trailer are carried out.

Insert the key of the combined emergency switch, turn it 90° clockwise and pull the button up.

Press the horn button (20) to activate the audible warning signal.

Hook the specific towing device into the present trailer **AND MAKE SURE THAT** the trailer is connected accordingly.

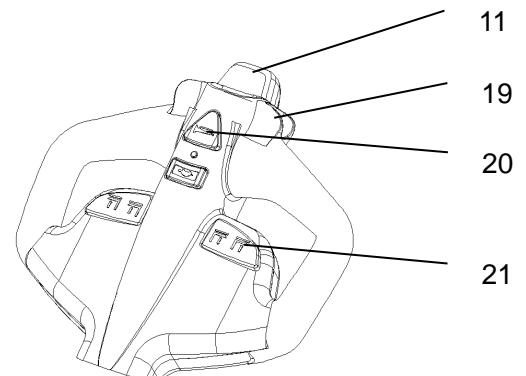

Fig.7: Tiller operating controls

### a. Parking



DO NOT PARK THE TRACTOR ON INCLINED SURFACES

The tractor is equipped with an electromagnetic failsafe stopping and parking brake.  
Press the emergency switch (13), turn the key 90° anti- clockwise and remove the key.

### b. Travelling



DO NOT OPERATE THE TRACTOR ON INCLINED SURFACES

After starting the tractor by pulling the emergency switch (1) and (13), move the tiller to the operating position.

Turn the accelerator button (19) to the desired direction forward 'Fw.' or backwards Bw.'(fig. 8).

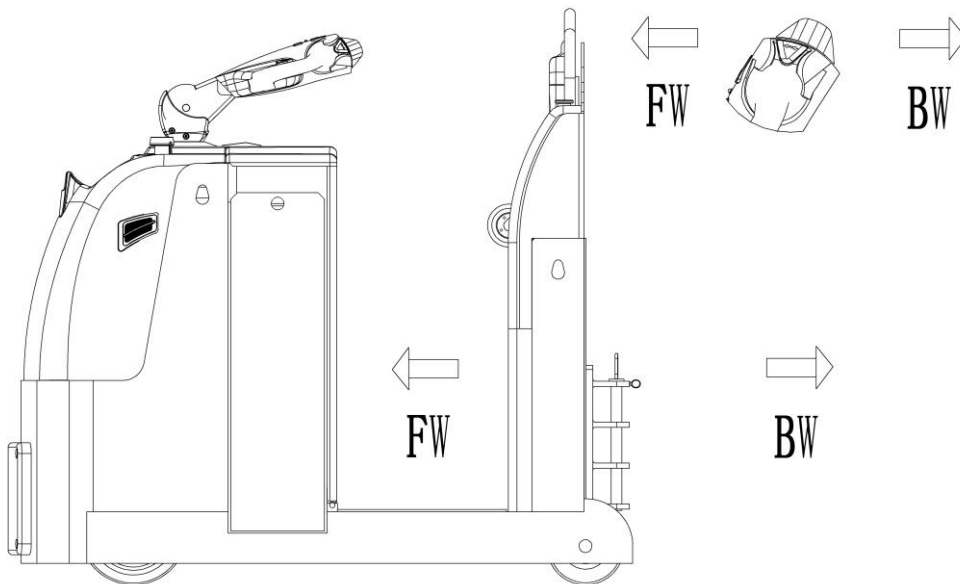

**Fig. 8:** Operating direction

Control the travelling speed by moving the accelerator button (19) carefully until you reached the desired speed.

If you move the accelerator button back to the neutral position, the controller decelerates the tractor until the tractor stops. If the tractor stopped, the parking brake will be engaged.

Drive carefully the tractor to the destination. Watch the route conditions and adjust the travelling speed with the accelerator- button.

### c. Steering

You steer the tractor by moving the tiller to the left or right side.

### d. Braking



THE BRAKING PERFORMANCE DEPENDS ON THE TRACK CONDITONS AND

## TRHE LOAD CONDITONS OF THE TRACTOR

The braking function can be activated on several ways:

- By moving the accelerator button (19) back to the initial '0' position or by releasing the button, the regenerative braking is activated. The tractor brakes until it stops.
- By moving the accelerator button (19) from one driving direction directly to the opposite direction, the tractor brakes regenerative until it starts travelling into the opposite direction.
- The safety stop button (11) stops travelling, when pushed. If this button is activated, the tractor decelerates the truck until the truck stops.

### e. Malfunctions

If there are any malfunctions or the tractor is inoperative, please stop using the tractor and activate the emergency button (13) by pushing it. If possible, park the tractor on a safe area and remove the combined locking key from the emergency button (13).

Inform immediately the manager and, or call your service. If necessary, tow the truck out of the operating area by using dedicated towing/ lifting equipment.

### f. Emergency

In emergencies or in the event of tip over (or off dock), keep safe distance immediately. If possible push the emergency button (13). All electrical functions will be stopped.

## 7. BATTERY CHARGING AND REPLACEMENT



- Only qualified personnel are allowed to service or charge the batteries. The instructions of this handbook and from the battery- manufacturer must be observed.
- These batteries are maintenance free; re- filling is prohibited.
- Recycling of batteries undergoes national regulations. Please follow these regulations.
- By handling batteries, open fire is prohibited, gases could cause explosion!
- In the area of battery charging neither burning materials nor burning liquids are allowed. Smoking is prohibited and the area must be ventilated.
- Park the tractor securely before starting charging or installing/changing the batteries
- Before finishing the maintenance work, make sure, that all cables are connected correctly and that there are no disturbing towards other components of the tractor.

As standard batteries, the truck is equipped with following liquid acid traction battery- type:

1 pc 3PzS 24V/ 465Ah [800x212x784 (LXWXH)]



IT IS ONLY ALLOWED TO USE SEALED LIQUID ACID BATTERIES.

THE WEIGHT OF THE BATTERIES HAS AN INFLUENCE TO THE TRACTORS OPERATING BEHAVIOR.

PLEASE CONSIDER THE MAXIMUM OPERATING TEMPERATURE OF THE BATTERIES.

### a. Replacement



EXCHANGING THE BATTERY TO THE SIDE REQUIRES SPECIAL EQUIPMENT, APPROPRIATED TO TAKE THE BATTERY SECURELY. ENSURE THAT THIS EQUIPMENT IS NOT MOVING BACKWARDS IF YOU MOVE OUT THE BATTERY BLOCK! PAY ATTENTION, THE BATTERY MIGHT FALL OUT, IF THE EQUIPMENT IS USED NOT CORRECTLY AND CAREFULLY!

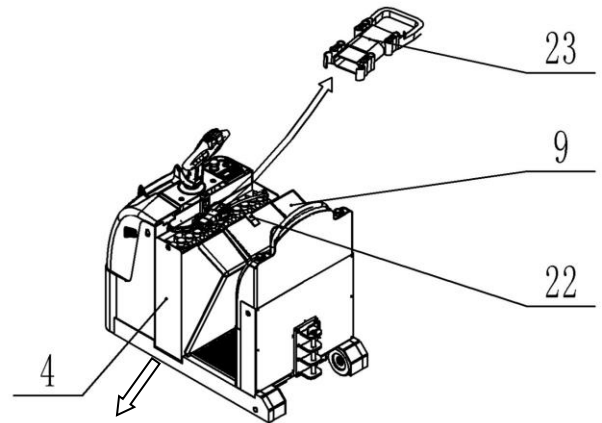

Fig. 9: Battery replacement

Park the truck securely and switch off the truck with the key switch (Fig. 1, pos. 14), and push the emergency button (1) or emergency button (13). Loosen the lock (22) and open the battery cover (9). Then remove the battery plug (Fig. 10, pos. 23), Then pull out the battery (4) according to fig. 9 to the securely parked and docked battery exchange system, if you would like to exchange to the side.

If you exchange the battery to the top, you have to use dedicated lashing equipment.

The installation is in the opposite direction of the removal.

### b. Battery indicator

Discharge status is indicated by ten red LED segments.

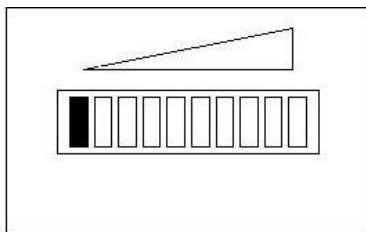

Battery discharged

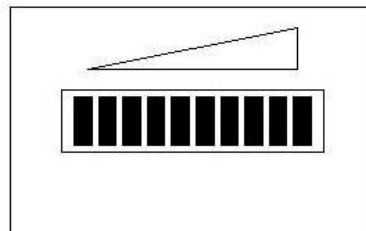

Battery full charged

Fig.10: Battery discharge indicator

Only when the battery is properly charged, the most right LED lit. As the battery's state-of-charge decreases, successive LEDs light up, only one on at a time.

- The 2nd from left LED flashes, indicating "energy reserve" (70% depth of discharge).

- The 2 most left LEDs alternately flash, indicating “empty” (80% depth of discharge).

### c. Charging



- It is only allowed to use the supplied charger for charging the installed batteries!
- Before using the charger, please fully understand the instructions of the charger instructions.
- Always follow these instructions!
- The room, where you are charging must be ventilated.
- The exactly charge status can be only checked from the dischrge indicator. To control the status, the charging must be interrupted and the tractor must be started.

Park the tractor at a dedicated secured area with a deidcated power supply.

Remove the trailer from the tractor.

Switch the tractor off and connect the battery plug to the charging plug of the charger.

The charger starts charging the battery if the charger is connected to the main power supply.

Disconnect the battery plug after the charger finished charging.

If supplied, assemble the battery cover. Connect the battery plug with the plug at the truck.

When charging is finished, disconnect the connector from the socket and place it in the designated pocket.

## 8. REGULAR MAINTENANCE



- Only qualified and trained personnel are allowed to do maintenance on this tractor.
- Before maintaining, remove the trailer from the tractor.
- If you need to lift the tractor, follow chapter 4b by using designated lashing or jacking equipment.
- Please pay attention by maintain the tiller arm. The gas pressure spring is pre-loaded by compression, carelessness can cause injury.
- Use approved and from your dealer released original spare parts.
- If you need to change the wheels, please follow the instructions above. The castors must be round and they should have no abnormal abrasion.  
Check the items emphasized maintenance checklist.

### a. Maintenance checklist

Table 3: Maintenance checklist

		Interval(Month)			
		1	3	6	12
Mechanical system					
7	Check the chassis for deformation and cracks		•		
8	Check if all screws are fixed		•		
10	Check the gearbox for noise and leakage		•		
11	Inspect the wheels for deformation and damages		•		

12	Inspect and lubricate the steering bearing				•
13	Inspect and lubricate the pivot points		•		
14	Check the air pressure for the wheels and if necessary refill air	•			
Electrical system					
15	Inspect the electric wiring for damage		•		
16	Check the electric connections and terminals		•		
17	Test the Emergency switch function		•		
18	Check the electric drive motor for noise and damages		•		
19	Test the display		•		
20	Check, if correct fuses are used		•		
21	Test the warning signal		•		
22	Check the contactor(s)		•		
23	Check the frame leakage (insulation test)		•		
24	Check function and mechanical wear of the accelerator		•		
25	Check the electrical system of the drive motor		•		
Braking system					
26	Check brake performance, if necessary replace the brake disc or adjust the air gap		•		
Battery					
27	Check the battery voltage		•		
28	Clean and grease the terminals and check for corrosion and damage		•		
29	Check the battery housing for damages		•		
Charger					
30	Check the main power cable for damages			•	
31	Check the start-up protection during charging			•	
Function					
32	Check the horn function	•			
33	Check the air gap of the electromagnetic brake	•			
34	Test the emergency braking	•			
35	Test the reverse and regenerative braking	•			
36	Test the safety (belly) button function	•			
37	Check the steering function	•			
39	Check the tiller arm switch function	•			
General					
40	Check if all decals are legible and complete	•			
41	Inspect the castors, adjust the height or replace these if worn out.		•		
42	Carry out a test run	•			

## b. Lubricating points

Lubricate the marked points according to the maintenance checklist. The required grease specification is: DIN 51825, standard grease.

1. Bearing
2. Gear box
3. Axle

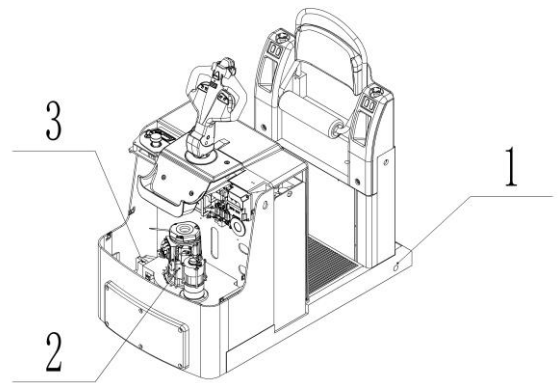

Fig. 11: Lubricating points

## c. Checking electrical fuses

Remove the main cover. The fuses are located according to fig. 12.

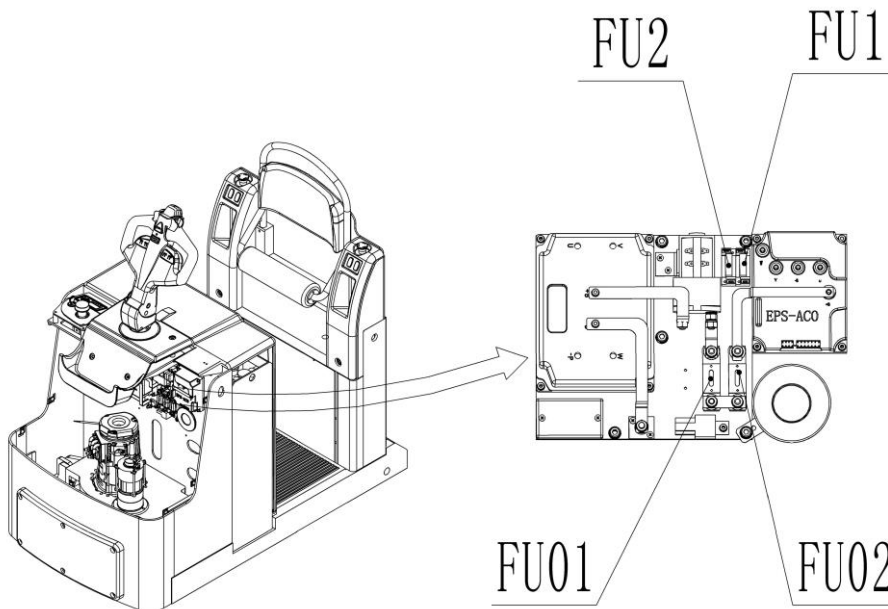

Fig. 12: Location fuses

Table 4: Size fuses

	Rate
FU01	200A
FU02	60A
FU 1	10A
FU 2	10A

## 9. TROUBLE SHOOTING



- If the tractor has malfunctions follow the instructions, mentioned under chapter 6.

Table 5: Trouble shooting

TROUBLE	CAUSE	REPAIR
Tractor not starts operating	Battery is charging	Charge the battery completely and then remove the main power plug form the electrical socket.
	Battery not connected	Connect the battery correctly
	Fuse faulty	Check and eventually replace fuses
	Low battery	Charge the battery
	Combined emergency switch is activated	De-activate the combined emergency switch by insert and pull the knob.
	Tiller in the operating position	Move the tiller firstly to the braking position.

If the tractor has malfunctions and can't be operated out of the working zone, jack the tractor up and go with a load handler under the tractor and safe the tractor securely. Then move tractor out of the aisle.



# 11. SPECIALIZED STIPULATIONS FOR THE US- AMERICAN MARKET

The content in this chapter is specialized for the US-American market.

## a. Foreword/ Compliance

Operating this tractor requires knowledge which can be acquired from this instruction handbook. This handbook must be kept available throughout the entire period of use of the industrial tractor.

**IT IS LAW; YOU MUST BE TRAINED AND CERTIFIED TO OPERATE THIS TRACTOR! READ AND OBEY ALL WARNINGS AND INSTRUCTIONS IN THIS MANUAL AND ON THE TRACTOR!**

Only properly trained operators are allowed to operate a powered industrial tractor. Your employer must train you and certify, that you are qualified to operate this tractor (required by OSHA § 1910.178). The training must satisfy OSHA requirements and as minimum the topics mentioned in this handbook. Depending on the context in this operating manual, the user can refer to several people, including the owner of the tractor, anyone who leases or borrows this tractor, and the operator as defined in ASME B56.1. Please pay attention to the section in ASME B56.1 concerning the operator. In this standard, it is defined that the safe operation is the responsibility of the operator (ASME B56.1-2003, Part II, section 5.1.1). You and others can be seriously injured or even killed if you don't use this tractor correctly. Before operating your tractor, inspect your tractor and ensure that it is in correct working order. This tractor was designed and built to current industry and government standards. For more information see following:

- ASME B56.1 (American Society of Mechanical Engineers)
- OSHA §1910.178 (Occupational Safety and Health Act)
- UL 583 (Underwriters Laboratory)
- ANSI Z535.4 (American National Standards Institute)

**⚠ DANGER** This sign indicates hazard situations, if not avoided, will result in serious injury or death. The instructions or precautions to this message must be observed to avoid the potential risk of injury or death.

**⚠ WARNING** If not followed, warning indicates hazard situations which may lead to moderate injury. The instructions or precautions to this message must be observed to avoid the potential risk of injury or death.

**⚠ CAUTION** If not followed, caution indicated situations which may lead to minor injury. Instructions or precautions must be observed to avoid minor injury.

## b. Description warning labels (only US- market)

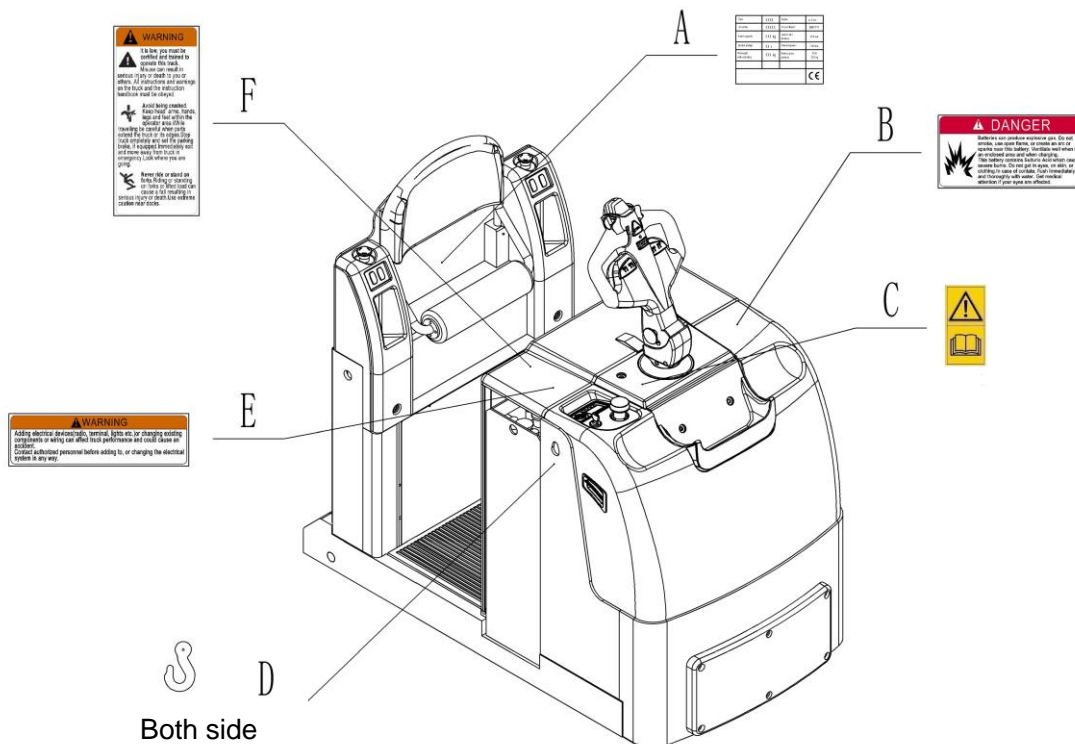

Fig. 14: Warning labels and safety devices (only USA)

- |   |  |   |                                      |
|---|--|---|--------------------------------------|
| A | Identification plate (ID-plate)              | D | Crane hook label                     |
| B | Sign danger battery                          | E | Sign warning electrical devices      |
| C | Sticker to read and follow these instruction | F | Sign warning stay clear stop tractor |

The tractor is equipped with an emergency switch (13) which stops driving- function and engages the failsafe electromagnetic brake when it is pushed. The function is described in chapter 2c. Follow the instructions given on the decals. Replace the decals if they are damaged or missing.

**Sign danger battery (B)**



**⚠ DANGER**

Batteries can produce explosive gas. Do not smoke, use open flame, or create an arc or sparks near this battery. Ventilate well when in an enclosed area and when charging. This battery contains Sulfuric Acid which cause severe burns. Do not get in eyes, on skin, or clothing. In case of contact, flush immediately and thoroughly with water. Get medical attention if your eyes are affected.

**Sign read and follow this instruction (C)**



**Sign warning electrical devices (E)**



**⚠ WARNING**

Adding electrical devices (radio, terminal, lights etc.) or changing existing components or wiring can affect truck performance and could cause an accident. Contact authorized personnel before adding to, or changing the electrical system in any way.

**Sign warning stay clear stop tractor (F)**

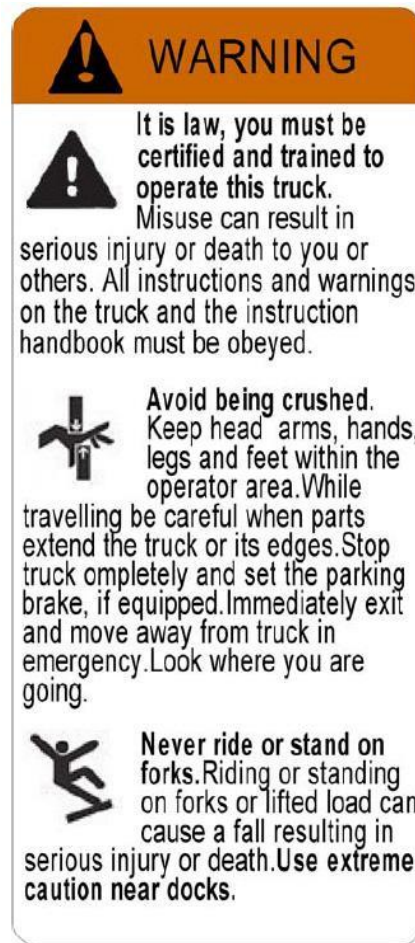

**⚠ WARNING**

**⚠ It is law, you must be certified and trained to operate this truck. Misuse can result in serious injury or death to you or others. All instructions and warnings on the truck and the instruction handbook must be obeyed.**

**⚠ Avoid being crushed. Keep head, arms, hands, legs and feet within the operator area. While travelling be careful when parts extend the truck or its edges. Stop truck completely and set the parking brake, if equipped. Immediately exit and move away from truck in emergency. Look where you are going.**

**⚠ Never ride or stand on forks. Riding or standing on forks or lifted load can cause a fall resulting in serious injury or death. Use extreme caution near docks.**

## c. Technical data for US market

Drawing see page 5

Table 6: Main technical data for standard version(US market)

Type sheet for industrial tractor acc. to VDI 2198				
Distinguishing mark	1.2	Manufacturer's type designation		T E30
	1.3	Power (battery ,diesel,petrol gas,manual)		Battery
	1.4	Operator type		Stand
	1.5	Load Capacity / rated load	Q(lbs)	6600
	1.7	Rated drawbar pull	F(N)	
	1.9	Wheelbase	Y(in)	41.4
Weight	2.1	Service weight	lbs	418.2
	2.3	Axle loading, unladen front/rear	lbs	259.1/159.1
Wheel chassis	3.1	Tires		R+PU
	3.2	Tire size, front	∅ x w (In)	∅9.8X3.2
	3.3	Tire size, rear	∅ x w (In)	∅7.1X3
	3.5	Wheels, number front/rear(x=driven wheels)		1+1X2
	3.6	Tread, front	b <sub>10</sub> (in)	----
	3.7	Tread, rear	b <sub>11</sub> (in)	25
Tires, Chassis	4.9	Height of tiller in drive position min./ max.	h <sub>14</sub> (in)	57/ 56/52.8/48.3
	4.19	Overall length	l <sub>1</sub> (in)	57.2
	4.21	Overall width	b <sub>1</sub> (in)	31.9
	4.32	Ground clearance, centre of wheelbase	m <sub>2</sub> (in)	1.97
	4.35	Turning radius	Wa (in)	53.1
Performance data	5.1	Travel speed, laden/ unladen	km/h	7.0/7.5
	5.5	Drawbar pull, laden/unladen	N	-----
	5.6	Max. drawbar pull, laden/unladen	N	-----
	5.10	Service brake		Electromagnetic
E- Motor	6.1	Drive motor rating S2 60min	HP	3.9
	6.3	Battery acc. to DIN 43531/ 35/ 36 A, B, C, no		No, 3PZS
	6.4	Battery voltage, nominal capacity K5	V/Ah	24/465
	6.5	Battery weight	lbs	171.4
Additional data	8.1	Type of drive control		DC- speed control
	8.4	sound level at driver's ear acc. to EN 12053	dB(A)	-----

## 12. DECLARATION OF CONFORMITY (valid, if sold within the EU)

### **[GB] CE Declaration of Conformity**

The signatory hereby declares that the specified machine conforms to the EU Directive 2006/42/EC (Machine Directive) and 2004/108/EEC (Electro-Magnetic Compatibility, EMC) including their amendments as translated into national legislation of the member countries. The signatory is individually authorized to compile the technical documents.

### **[D] EG-KONFORMITÄTSEKTLÄRUNG**

Der Unterzeichner bescheinigt hiermit, dass die im Einzelnen bezeichnete Maschine den Europäischen Richtlinien 2006/42/EG (Maschinenrichtlinie) und 2004/108/EG (Elektromagnetische Verträglichkeit - EMV) einschließlich deren Änderungen sowie dem entsprechenden Rechtsersatz zur Umsetzung der Richtlinien in nationales Recht entspricht. Der Unterzeichner ist bevollmächtigt, die technischen Unterlagen zusammenzustellen.

### **[E] DECLARACIÓN DE CONFORMIDAD CE**

El signatario certifica por medio de la presente que la máquina especificada cumple con las Normas Europeas 2006/42/CE (Normativa para maquinarias) y 2004/108/CE (Compatibilidad electromagnética), incluyendo sus respectivas modificaciones, así como con el decreto-ley para la adaptación de las normas al derecho nacional. El signatario dispone de una autorización individual que le permite compilar la documentación técnica.

### **[F] DECLARATION DE CONFORMITE CE**

Par la présente déclaration, les soussignés certifient que le machines spécifiées ci-dessus est conforme à la loi et aux directives européennes 2006/42/CE (directive sur les machines) et 2004/108/CEE (compatibilité électromagnétique - CEM), y compris aux modifications qui y sont apportées et à l'arrêté autorisant sa transposition en droit national. Chaque signataire est habilité à établir individuellement la documentation technique.

### **[NL] EG-CONFORMITEITSVERKLARING**

Ondergetekenden verklaren hierbij dat - volgens de nationale wetgeving van de Lidstaten - de hierboven vermelde opgegeven machina beantwoordt aan de bepalingen qua veiligheid bij machines (EG richtlijn 2006/42/EC) en electro-magnetische compatibiliteit (EG richtlijn 2004/108/EEC). Ondergetekenden zijn ieder individueel gemachtigd het technisch dossier samen te stellen.

### **[P] DECLARAÇÃO DE CONFORMIDADE CE**

Pela presente, os signatários certificam que o máquina especificado está conforme às Directivas Europeias 2006/42/CE („Máquinas“) e 2004/108/CEE („Inocuidade Electromagnética - IEM“), incluindo as alterações das mesmas e o respectivo decreto-lei para a transposição em lei nacional. Cada um dos signatários está autorizado a proceder à elaboração da documentação técnica.

### **[I] DICHIARAZIONE DI CONFORMITÀ CE**

I sottoscritti dichiarano che il veicolo per trasporti interni a macchina specificato soddisfa le Direttive Europee 2006/42/EC (Direttiva Macchine) e 2004/108/EEC (Compatibilità elettromagnetica - EMV) comprese le relative modifiche, come pure il rispettivo decreto legislativo per la conversione delle direttive in diritto nazionale. I sottoscritti sono singolarmente autorizzati alla creazione della documentazione tecnica.

### **[BG] ЕВРОПЕЙСКА ОБЩНОСТ - ДЕКЛАРАЦИЯ ЗА СЪОТВЕТСТВИЕ**

Подписаните удостоверяват с настоящето, че подробно описаното машина средство отговаря на европейския норматив 2006/42/EG (норматив за машини) и на 2004/108/EG (електро-магнетична съвместимост), включително с техните промени, както и на съответния указ за прилагане на нормативите в националното право. Подписаните при това са упълномощени поотделно да съставят техническата документация.

### **[CZ] EG - PROHLÁŠENÍ O SHODĚ**

Níže podepsaný tímto potvrzuje, že podrobný popis uvedené stroje odpovídá Evropským směrnicím 2006/42/EC (směrnice pro stroje) a 2004/108/EEC (elektromagnetická interference - EMV) včetně jejich pozdějších úprav, jakož i příslušným právním výnosům pro uplatnění příslušné směrnice v rámci národního práva. Každý z podepsaných jsou jednotlivě způsobilí k vytvoření technických podkladů.

### **[DK] EF-OVERENSSTEMMELSESEKTLÆRING**

Undertegnede attesterer hermed, at det specificerede maskine stemmer overens med de Europæiske Direktiver 2006/42/EU (maskindirektiv) og 2004/108/EØF (elektromagnetisk kompatibilitet - EMC) samt med den modsvarende lovedtagelse til implementering af direktiver i den nationale lovgivning. De undertegnede er hver for sig beføjet til at sammenstille de tekniske dokumenter.

### **[EST] EL vastavusavaldus**

Allakirjutatud tõendavad käesolevaga, et üksikasjaliselt kirjeldatud täpsustatud masin vastab Euroopa direktiividele 2006/42/EÜ (Direktiiv masinate kohta) ja 2004/108/EMÜ (Elektromagnetiline sobivus - EMS) kaasa arvatud nende muudatused ja nende vastavatele õigusmäärustele direktiivide muutmiseks siseriiklikuks õiguseks. Iga allakirjutanu üksikult on volitatud koostama tehnilist dokumentatsiooni.

### **[FIN] EU-YHDENMUKAISUUSSELOSTUS**

Allekirjoittaneet todistavat täten, että kukin erikseen mainittu omalla voimanlähteellä varustettu tehdaskone vastaa EU-direktiivien 2006/42/EC (koneenrakennusdirektiivi) ja 2004/108/EEC (sähkömagneettinen yhteensopivuus – EMC) määräyksiä sekä niiden kansalliseen lainsäädäntöön soveltamista koskevaa oikeussääntöä. Jokaisella allekirjoittaneista on oikeus itsenäisesti laatia asiaankuuluvia teknisiä asiakirjoja.

### **[GR] ΔΗΛΩΣΗ ΣΥΜΜΟΡΦΩΣΗΣ ΕΟΚ**

Οι υπογράφωντες βεβαιώνουν διά της παρούσης ότι το συγκεκριμένο μηχάνημα συμμορφώνεται προς την Κοινοτική Οδηγία 2006/42/ΕΚ («Μηχανήματα») και 2004/108/ΕΟΚ (Ηλεκτρομαγνητικής Συμβατότητας, ΗΜΣ), καθώς και οι τροποποιήσεις τους, όπως μεταφράστηκε στην εθνική νομοθεσία των χωρών μελών. Οι υπογράφωντες είναι σε κάθε περίπτωση εξουσιοδοτημένοι ατομικά να καταρτίσουν τα τεχνικά έγγραφα.

### **[H] EU KONFORMITÁSI NYILATKOZAT**

Alulírottak ezennel igazolják, hogy a részletesen leírt a megadott gép megfelel a 2006/42/EC (Gép-Irányelv) és a 2004/108/EEC (Elektromágneses összeférhetőség - EMV) Európai Irányelveknek, beleértve azok módosításait, valamint az irányelvek nemzeti jogba történő átültetésére irányuló megfelelő jogi rendelkezést. Továbbá az alulírottak mindegyike rendelkezik meghatalmazással arra nézve, hogy összeállíthatja a műszaki dokumentációt.

### **[LT] ES atitikimø deklaracija**

Žemiau pasirašę asmenys patvirtina, kad atskirai aprašytas nurodyta mašina atitinka Europos Sąjungos direktyvas 2006/42/EB (Mašinų direktyva) ir 2004/108/EEB (Elektromagnetinis suderinamumas – EMS) įskaitant jų pakeitimus, o taip pat ir atitinkamą teisės aktą dėl direktyvų įgyvendinimo nacionalinėje teisėje. Kiekvienas iš pasirašusių asmenų turi teisę ruošti techninę dokumentaciją.

### **[LV] ES atbilstības deklarācija**

Ar zemāk redzamajiem parakstiem tiek apliecināts, ka norādīts mašina atbilst Eiropas Savienības normatīvām 2006/42/EG (Mašīnu normatīvas) un 2004/108/EWG (Elektromagnētiskā atbilstība – EMV), ieskaitot to izmaiņas, kā arī atbilstošos tiesiskos rīkojumus normatīvu pielāgošanai nacionālajai

likumdošanai. Parakstu īpašnieki ir atsevišķi pilnvaroti sastādīt tehniskās dokumentācijas.

### **[N] EU-KONFORMITETSERKLÆRING**

Undertegnede bekrefter hermed at de enkelte betegnede maskin med kraftdrift tilsvarer de europeiske retningslinjene 2006/42/EC (maskinretningslinje) og 2004/108/EEC (elektromagnetisk fordraglighed - EMV) inklusiv disses endringer og den tilsvarende rettsforordning til omsetning av nasjonal rett. Hver undertegnede er fullmektig til å sette sammen de tekniske dokumentene.

### **[PL] DEKLARACJA ZGODNOŚCI WE**

Niżej podpisani deklarują, że poniżej opisana maszyna spełnia wymagania określone w dyrektywach Europejskich 2006/42/EC (Dyrektywa Maszynowa) i 2004/108/EEC (Kompatybilności elektromagnetycznej - EMC) wraz z ich późniejszymi zmianami oraz odpowiednimi rozporządzeniami mającymi na celu przeniesienie tych dyrektyw do prawa krajów członkowskich. Sygnatariusz jest indywidualnie upoważniony do zestawiania dokumentacji technicznej.

### **[RO] DECLARAȚIE DE CONFORMITATE CE**

Subsemnatii adevăresc prin prezenta că vehiculul de specificat mașină descris individual corespunde directivelor europene 2006/42/CE (Directiva privind mașinile) și 2004/108/CEE (Compatibilitatea electromagnetica - CEM) inclusiv modificărilor lor precum și actului legislativ corespunzător pentru transpunerea directivelor în drept național. Subsemnatii sunt fiecare în parte împuterniciți să întocmească documentația tehnică.

### **[RUS] Декларация соответствия стандартам ЕС**

Настоящим лица, подписавшие документ, удостоверяют, что машина с указанной спецификацией соответствует европейским стандартам 2006/42/EG (Транспортная директива) и 2004/108/EWG (Электромагнитная совместимость - EMC), включая изменения в них, а также соответствующим национальным стандартам и нормам. Каждое по отдельности лицо, подписавшее документ, имеет полномочия для составления технической документации.

### **[S] EG-KONFORMITETSFÖRKLARING**

Undertecknarna intygar härmed att det i detalj betecknade maskin uppfyller de Europeiska direktiven 2006/42/EG (Maskindirektiv) och 2004/108/EEG (Elektromagnetisk tålighet - EMV), inklusive ändringarna i detta och den motsvarande rättsförordningen för att omsätta direktiven i nationell rätt. Undertecknarna har var för sig fullmakt att sammanställa den tekniska dokumentationen.

### **[SK] vyhlásenie o zhode**

Dolu podpísaní týmto potvrdzujeme, že podrobný popis uvedené stroje zodpovedá Európskym smerniciam 2006/42/EC (ernica pre stroje) a 2004/108/EWG (elektromagnetická tolerancia – EMV) vrátane jeho neskorších úprav, rovnako zodpovedá aj príslušným právnym nariadeniam na uplatnenie smerníc v rámci národného práva. Každý z podpísaných je jednotlivo splnomocnený na vytvorenie technických podkladov.

### **[SLO] EU IZJAVA O SKLADNOSTI**

Podpisani s tem potrjujemo, da posamično označeno določeno stroj vozilo odgovarja Evropski direktivi 2006/42/EC (Direktiva o strojih) in 2004/108/EEC (Elektromagnetna skladnost - EMV) vključno z njihovimi spremembami ter ustrezno pravno uredbo o prevzemu smernic v nacionalno pravo. Podpisniki so vsakokrat posamezno pooblašteni za izdajanje tehnične dokumentacije.

### **[TR] AB Uygunluk Açıklaması**

İmza sahibi şahıslar, ayrıntıları belirtilen makine aracının, 2006/42/EC (Makine Yönergesi) ve 2004/108/EEC (Elektromanyetik Uyumluluk – EMC) no'lu Avrupa Yönergelerine ve bunların değişiklik sonucu oluşan metinlerine ve yönergelerin milli hukuk hükümlerine dönüştürülmesine dair ilgili hukuk karamamesine uygun olduğunu tasdik ederler. İmza sahibi şahıslar teknik dosyaları bir araya getirmek için münferiden vekil tayin edildi.

- (1) Type/ Typ/ Tipo/ Modello/ Түүрпи/ Tipo / ΤΥΠΟΣ/ Tipus/ Tip/ Тип/ Tips/ Tipas/ Tüüp:
- (2) Serial No./ Serien-Nr./ N°. de série/ Seriennummer/ N° de serie/ Numero di serie/ Serien/ Serjanro/ αυξάνων αριθμός/ Serionév číslo/ Szériaszám/ Nr. Seryjny/ Serijska številka/ Výrobné číslo/ Серийный номер/ Seri No./ Seerianr./ Sērijas Nr./ Serijos numeris:
- (3) Year of constr./ Baujahr/ Année de constr./ Bouwjaar/ Año de constr./ Anno di costruzione/ Produktionsår/ Byggeår/ Tillverkningsår/ Valmistusvuosi / Ano de fabrico / έτος κατασκευής/ Rok výroby/ Gyártási év/ Rokprodukcji / Letnik / Год изготовления / Üretim yılı / Väljalaskeaasta / Izgatavošanas gads / Gamybosmetai
- (4) Manufacturer or his authorized representative in Community/ Hersteller oder in der Gemeinschaft ansässiger Vertreter/ Fabricant ou son mandataire établi dans la Communauté/ Fabrikant of zijn in de Gemeenschap gevestigde gemachtigde/ Fabricante o representante establecido en la Comunidad/ Construtor ou Representante estabelecido na Comunidade/ Costruttore oppure il suo rappresentante nella Comunità/ Fabrikant eller dennesi Fællesskabet etablerede befuldmægtigede/ Produsent eller agent innen felleskapet/ Tillverkare eller representant inom EU/ Valmistaja tai yhteisömaassa oleva edustaja / V'robce nebo jeho zastoupení/ Gyártó / producent albo jego przedstawiciel w EG (Wspólnota Europejska)/ Κατασκευαστής ή ο άρτινο ηνπιθώλ αληηπξνζώποσ/ Üretici ya da Bölgedeki Yetkili Temsilci/ Proizvajalec ali pooblašteni zastopnik s sedežem v EU/ Výrobca alebo zástupca so stálym bydliskom v EÚ / Изготовитель или его представитель, зарегистрированный в стране Содружества/ Tootja või organisatsioonis paiknev esindaja/ Ražotājs vai vietējais uzņēmuma pārstāvis / Gamintojas arba šalyje reziduojantis atstovas:
- (5) Date/ Datum/ Data/ Fecha/ datum/ Dato/ päivāys/ Kuupäev/ Datums/дата / Datum/ dátum/ tarih/ ημερομηνία
- (6) Authorised signatory/ Im Auftrag/ pour ordre/ Incaricato/ Por orden de/ por procuração/ op last van/ på vegne af/ på uppdrag/ Etter oppdrag/ psta./ Ülesandel / pavedus / v. i. / По поручению / megbízásából / длъжностно лице / z pověřením / z poverenia / po nalogu / na polecenie / din sarcina / adina / θαη' εληνηή

(1) Type: **XX XX – Self-propelled industrial truck**

(2) Serial No: **XXXXXXXX**

(3) Year of constr.: **YYYY**

(4) Manufacturer or his authorized representative in Community:  
**Company name/ Street / Postal code Town/ Country**

(5) Date: **YYYY-MM-DD**

(6) Authorized signatory: **Mr. Sample**

*If you can read this text, your declaration is not complete. In this case please ask for a copy*